

YORK PREACHER
CURL ATTACHMENT
CODE NO.5621

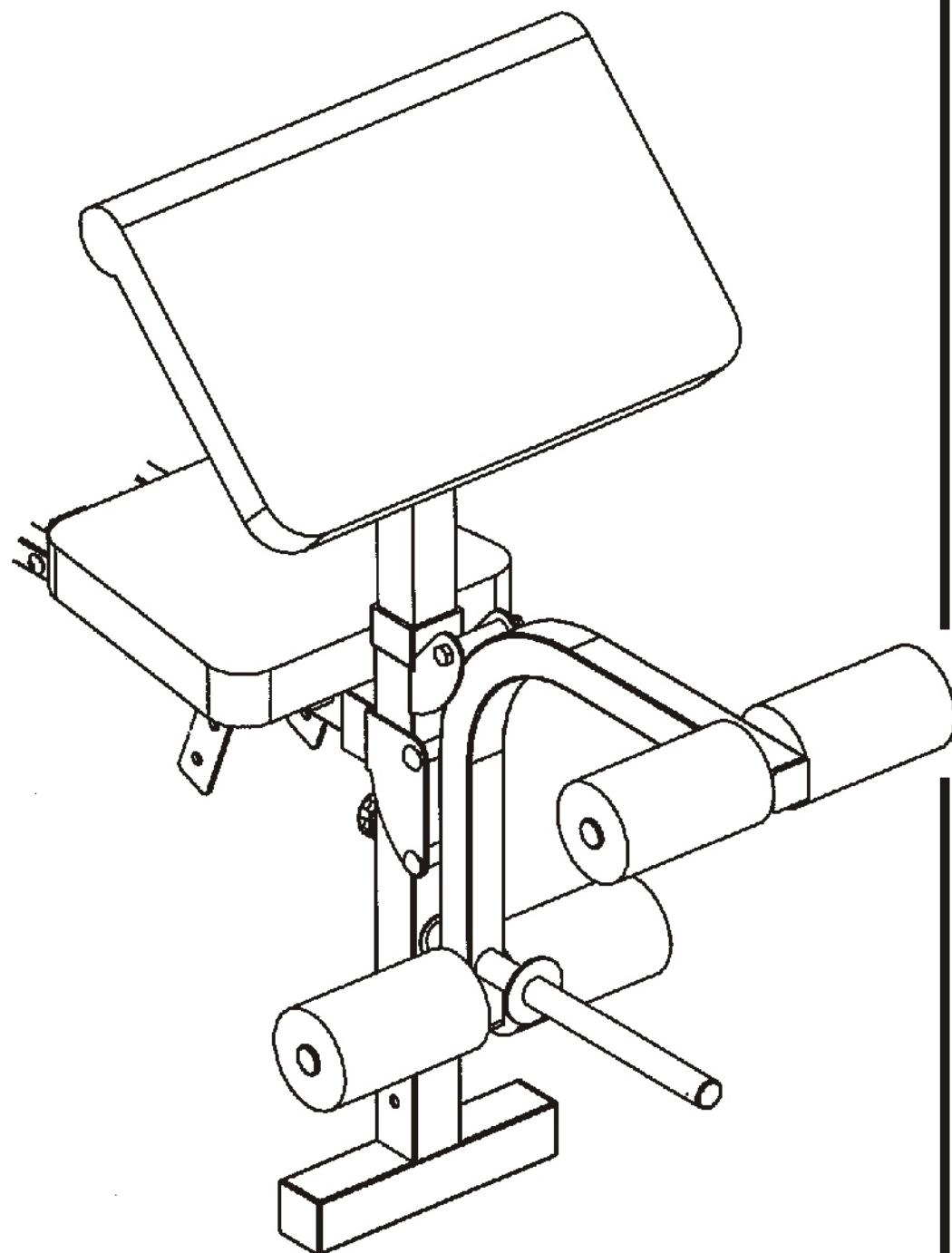

INSTRUCTION MANUAL

YORK
FITNESSES[®]

YORK® - PREACHER CURL ATTACHMENT

SAFETY GUIDELINES:

BEFORE ASSEMBLY

- This must be read before you start assembling this unit.
- Great care has been taken in design and how to assemble this unit.
- All bags of nuts and bolts have been packed with ease of assembly in mind.
- You must follow the assembly instructions exactly as outlined.
- You will need at least one person to help you assemble this unit, two would be better.
- Assemble this unit starting at the beginning and work to the end.
- The assembly instructions are set out so that you are only doing one section at a time, therefore you will finish one section and move on to the next.
- If something is missing when assembling this unit, you must notify us of the part number of the exact nut, bolt of part that is missing.
- To help you assemble this unit we have used line drawings.
- Check the line drawings for the exact positioning of the parts.
- The unit will need to be checked at least once a week for nuts and bolts that can work loose, upholstered pieces working loose and wear on pivot assemblies.

WARNING: YOU ARE RESPONSIBLE FOR YOUR OWN SAFETY!!

WARNING

1. Always consult your doctor before undertaking any exercise program.
 2. Ensure that all nuts and bolts are fully tight before using any exercise equipment.
 3. Always wear suitable clothing and footwear e.g. tracksuit and training shoes.
 4. Children should not be allowed on or around the machinery or equipment, even when not in use.
 5. Do not eat large meals 2 to 3 hours before exercising.
 6. Always warm up well before exercising as this will prevent straining muscle.
 7. Always read and follow the manufacturers assembly and user instructions.
 8. Remove jewelry, rings, chains and pins before exercising.
 9. Check for full engagement of locking pins.
 10. Check that any of the adjustment devices are not projecting.
 11. Give special attention to the cables, pulleys and locking devices as they may wear.
 12. Inquiries to health may result from incorrect or excessive training.
 13. Always use your bench on a flat level surface.
 14. Always use your bench in adequate space e.g. at least 2ft. (60cm) clearance on each side and front (the rear can be close to a wall).
- N.B. this list should not be taken as exhaustive.

CARE AND MAINTENANCE

Use a warm, damp cloth with mild detergent to keep your preacher curl attachment clean.

SHOULD YOU REQUIRE ANY ASSISTANCE REGARDING THIS PRODUCT PLEASE CONTACT YORK DIRECTLY.

U.K.	AUSTRALIA	U.S.A.
YORK FITNESS HELP LINE (8:30am- 4:30pm) YORK BARBELL (U.K.) LTD. CHURCHILL WAY, DAVENTRY, NORTHANTS, NN11 4YB ENGLAND TEL: (01327) 701-824 FAX: (01327) 706-704 E-MAIL: helpdesk@yorkfitness.co.uk	YORK FITNESS HELP LINE (8:00am- 4:00pm) YORK BARBELL (AUST.) PTY. LTD. UNIT 1, LOT 2, SWAFFHAM ROAD, MINTO, N.S.W. 2566 AUSTRALIA TEL: (02) 9603-8444 FAX: (02) 9603-8555 E-MAIL: service@yorkfitness.com.au	YORK FITNESS HELP LINE (8:00am- 5:00pm) YORK BARBELL USA. 3300 BOARD ROAD. YORK, PA 17402 TEL: +1-717-767-6481 FAX: +1-717-764-0416 E-MAIL: info@yorkbarbell.com

FITTING PREACHER CURL ATTACHMENT TO YOUR BENCH

- Attach the **ARM REST UPHOLSTERY (2)** to the outside face of the **ADJUSTABLE ARM REST POST (1)**.

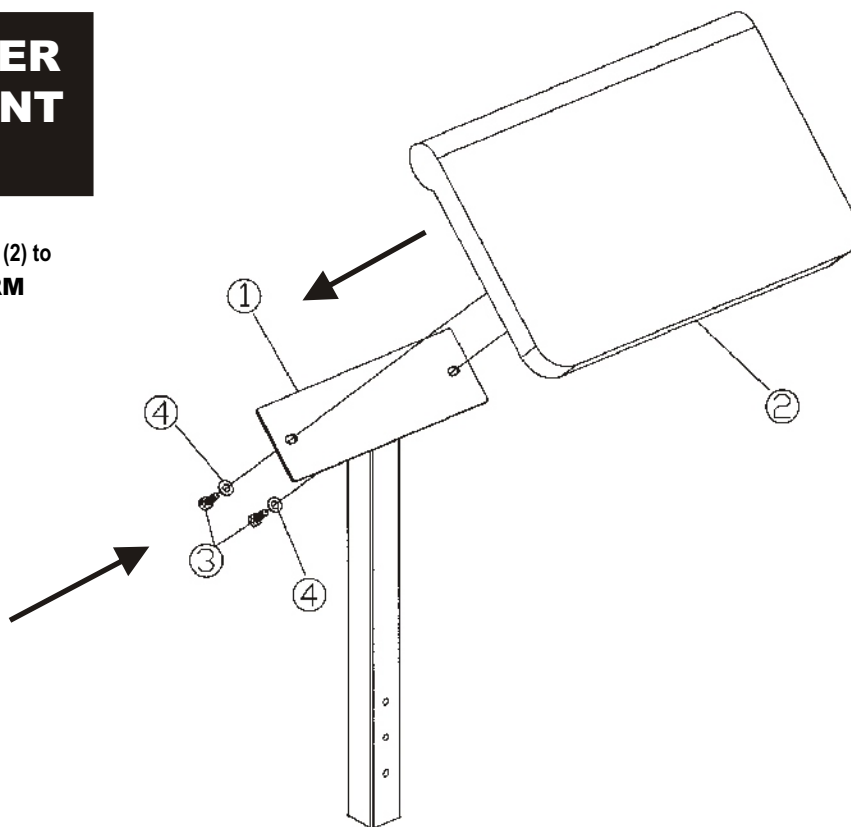
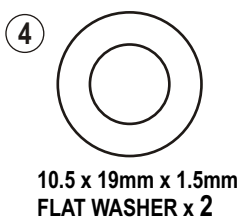
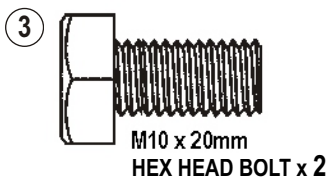

TIGHTEN ALL NUTS AND BOLTS ON ASSEMBLY.

- Loosen the **HAND WHEEL KNOB** at the rear of the bench **FRONT UPRIGHT POST**.
- Slot the **CURL ARM REST POST ASSEMBLY** into the top of the **FRONT UPRIGHT POST** and secure using the **HAND WHEEL KNOB**.

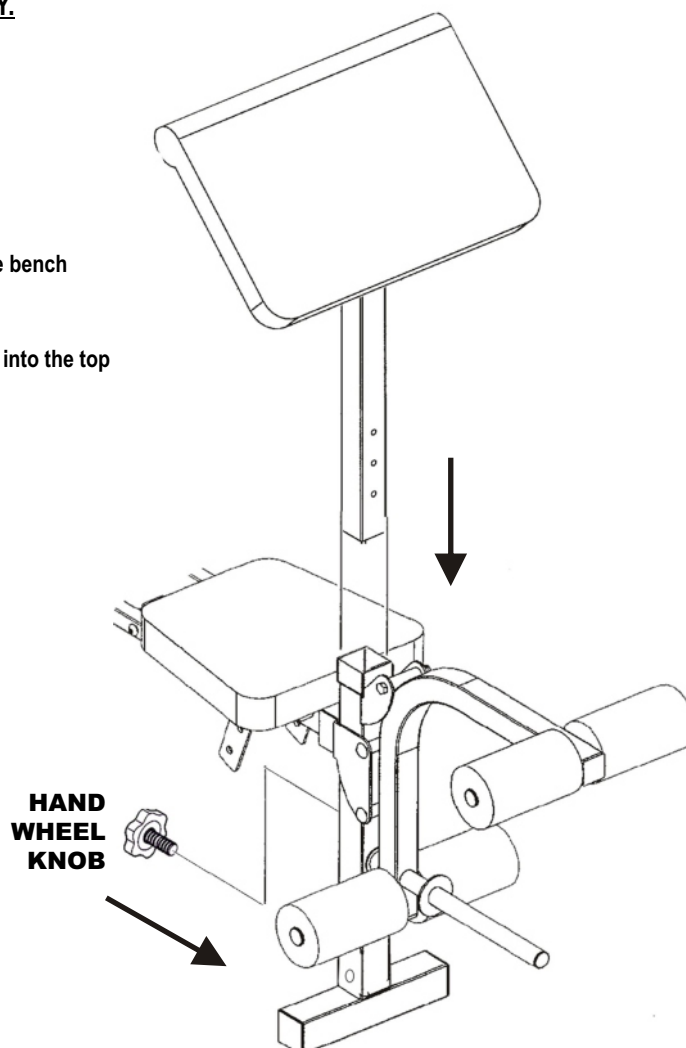

DESCRIPTION

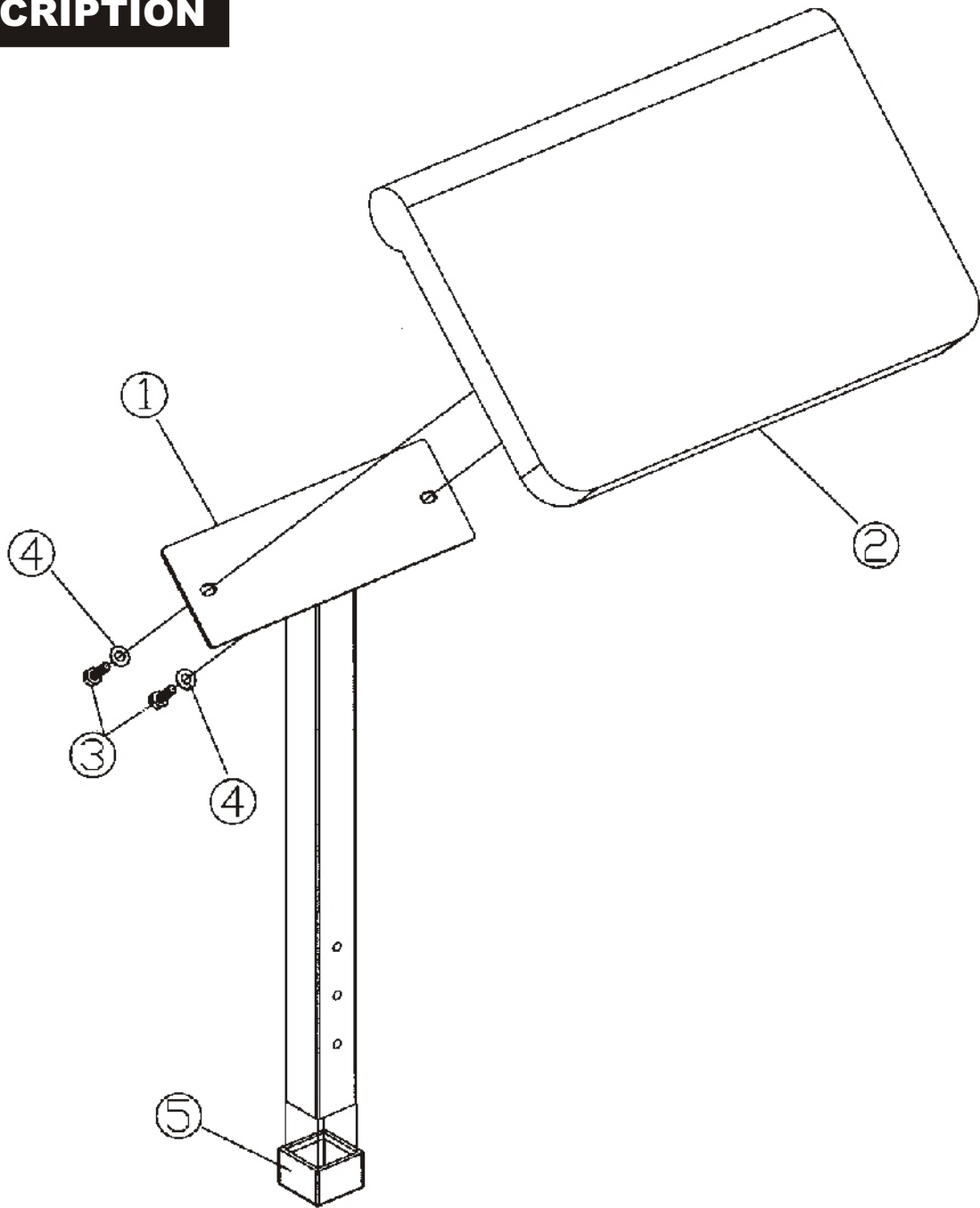

PARTS LIST

	PART NO.	Q'TY	DESCRIPTION
1	# 5621-01	1	ADJUSTABLE ARM REST POST
2	# 5621-02	1	ARM REST UPHOLSTERY
3	# 5621-03	2	M10 X 20mm HEX HEAD BOLT
4	# 5621-04	2	10.5mm X 19mm X 1.5mm WASHER
5	# 5621-05	1	50mm SQUARE REDUCER CAP