

YORK ***BODYGYM***
FITNESS

IMPORTANT

DO NOT UNPACK

PLEASE FOLLOW THESE
INSTRUCTIONS

INTRODUCTION

YORK BODY GYM has been designed and constructed to provide trouble free usage and enjoyable exercise.

You can greatly improve your understanding of the benefits of exercising by carefully reading the instructions given in this manual.

Please familiarize yourself with the **SAFETY GUIDELINE** provided for you.

■ There is a **SAFETY CABLE** --- It prevents the upholstery going as far as the end stops.

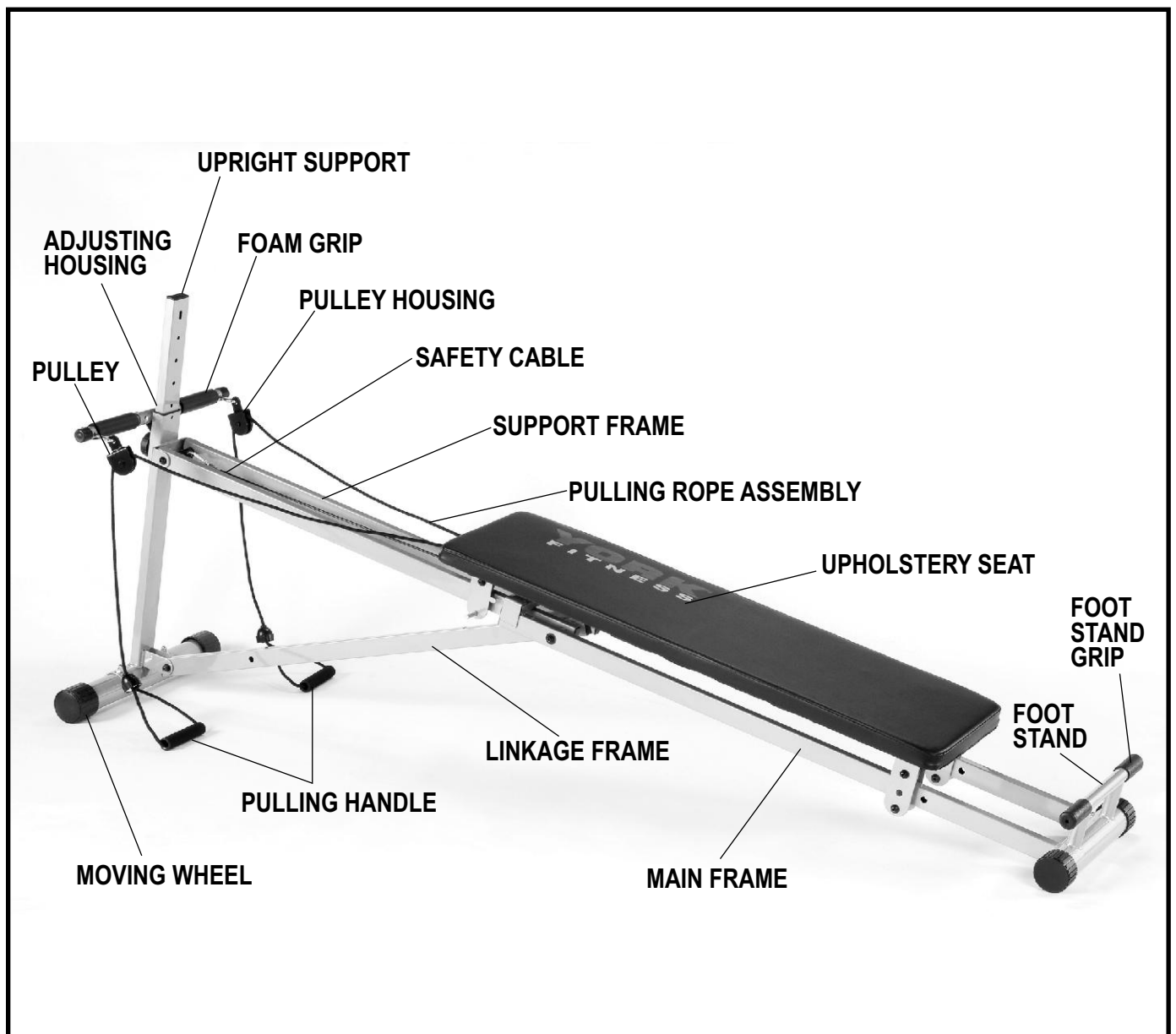

*** SHOULD YOU REQUIRE ANY ASSISTANCE REGARDING THIS PRODUCT PLEASE CONTACT YORK DIRECTLY. ***

ASSEMBLY INSTRUCTIONS

Before removing your BODY GYM from the carton please ensure that you follow these assembly steps.

YOU WILL NEED AT LEAST ONE PERSON TO HELP YOU ASSEMBLE THIS UNIT.

1.

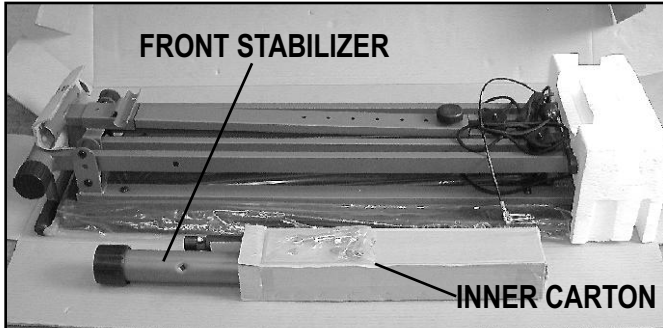

- Find the front stabilizer and the pulley housing support from inner carton packed with your BODY GYM

2.



- Raise the front end of the upright support with one hand, and put the inner carton under the support with the other.
- Attach the front stabilizer to the upright support and secure, using two carriage bolts, curved washers and capnuts. (The front stabiliser has moving wheels on each end.)

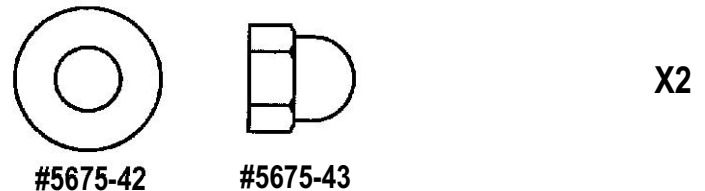
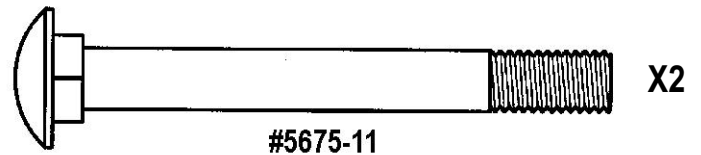

NOTE: Make sure you fasten the bolts securely for your safety and comfort when using this product.

3.

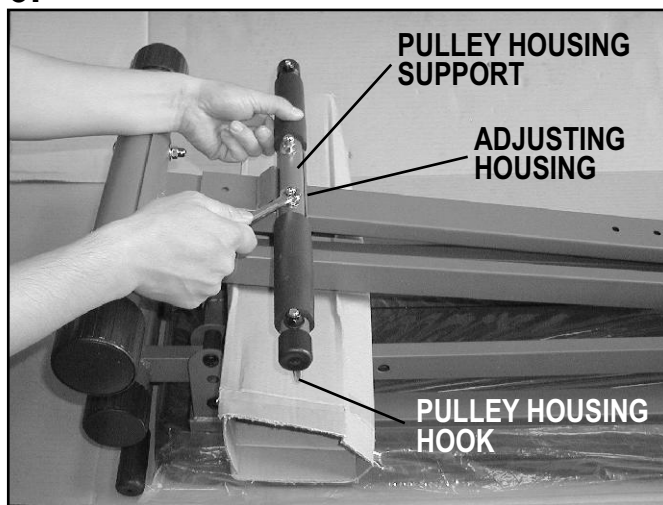

- Fit the pulley housing support to the adjusting housing bracket and secure, using two carriage bolts, curved washers and capnuts.

NOTE: Make sure the pulley housing hooks are facing downwards when you assemble.

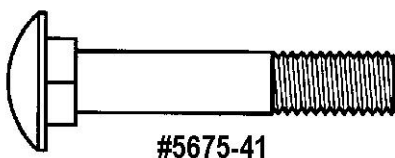

* SHOULD YOU REQUIRE ANY ASSISTANCE REGARDING THIS PRODUCT PLEASE CONTACT YORK DIRECTLY. *

4.



- Remove all the parts of your BODY GYM from the carton and fold it up to stand on the floor carefully as shown.
- If the weight is too heavy for you, get someone to help

5.

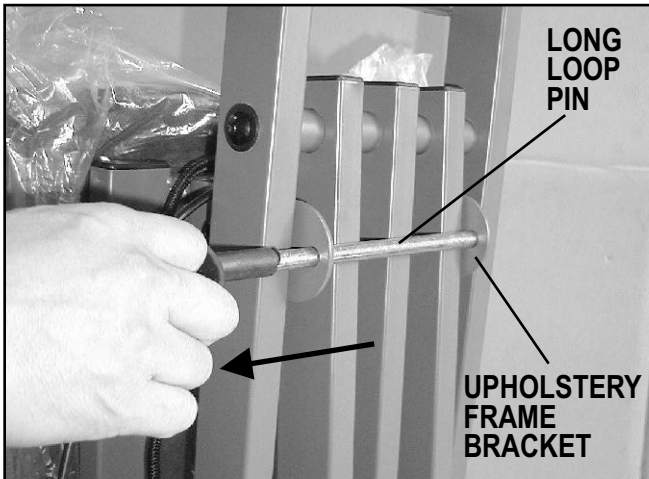

- Remove the long loop pin from the upholstery frame bracket as shown.

6.

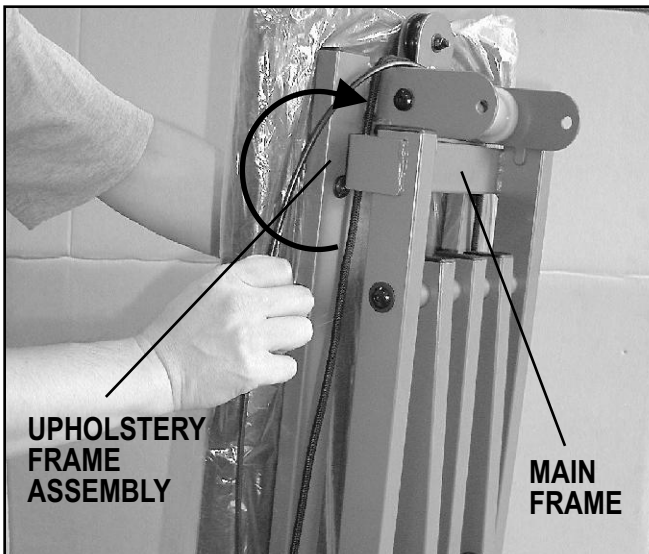

- Pull the upholstery frame back, then up, then forward and down, so that the upholstery frame hooks over the main frame as shown.

*** SHOULD YOU REQUIRE ANY ASSISTANCE REGARDING THIS PRODUCT PLEASE CONTACT YORK DIRECTLY. ***

YORK BODY GYM / 03

7.

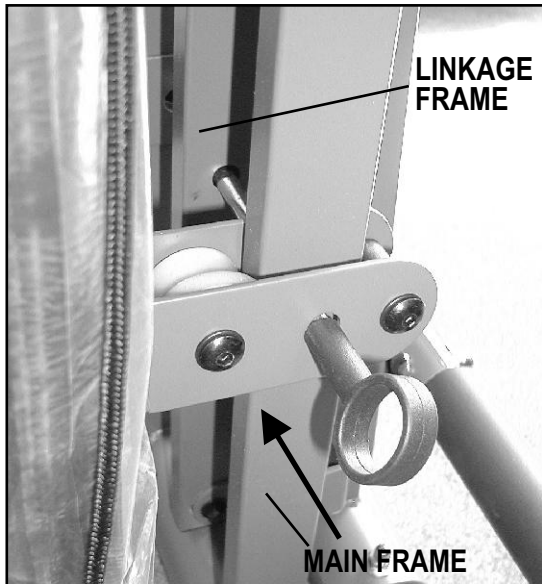

- Insert the long loop pin through the locking hole in the main frame and linkage frame as shown.

8.

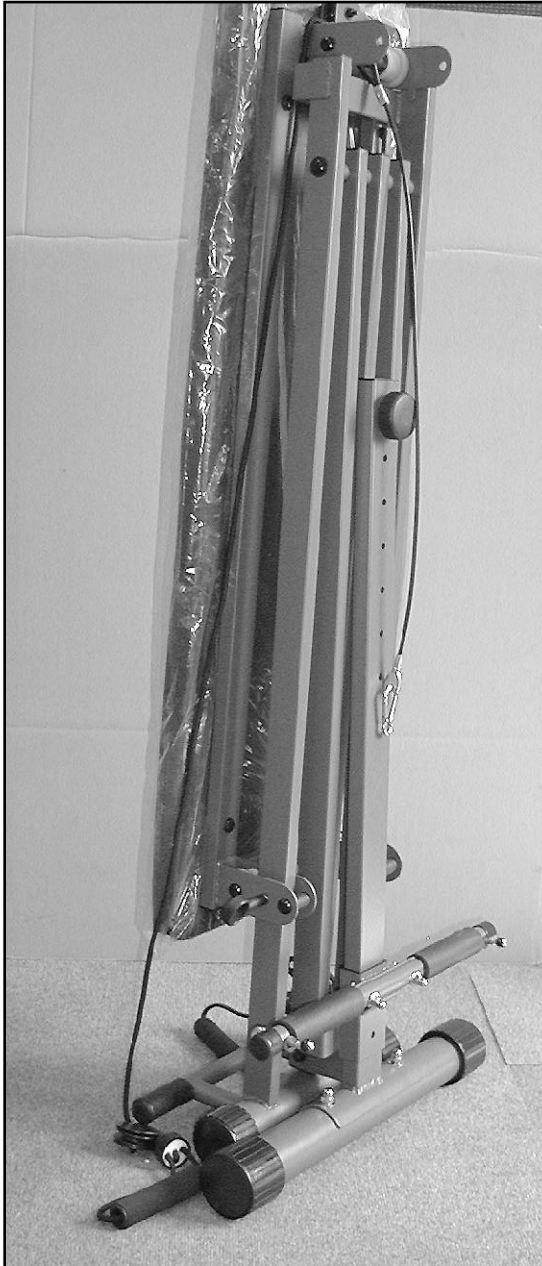

- **NOW**, your BODY GYM is in the folded position for easy storage.

*** SHOULD YOU REQUIRE ANY ASSISTANCE REGARDING THIS PRODUCT PLEASE CONTACT YORK DIRECTLY. ***

YORK BODY GYM / 04

TO FOLD OUT YOUR BODY GYM - READY FOR USE.

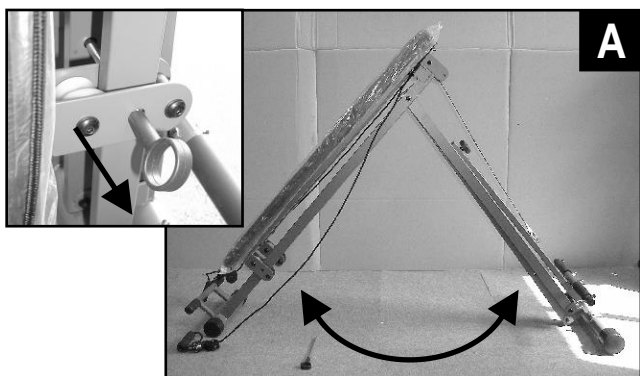

- Remove the long loop pin from locking hole, carefully fold out your BODY GYM main frame until extended.



- Remove the adjusting knob from the linkage frame.

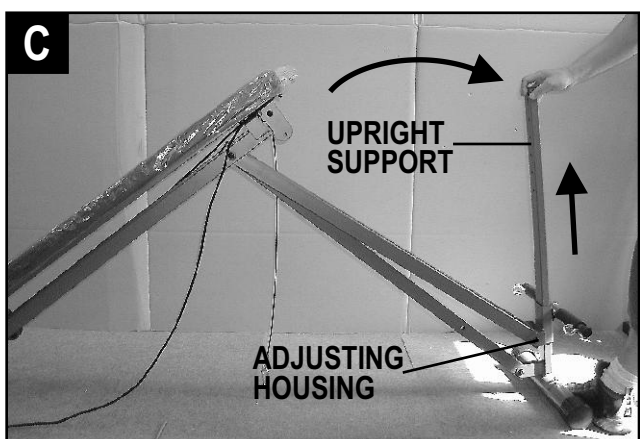

- Raise the upright support towards you vertically and slide the adjusting housing up the upright support.

NOTE: Use your foot to stop the front stabilizer from moving while you fold out your BODY GYM. This will make it easier to extend it on the floor safely.

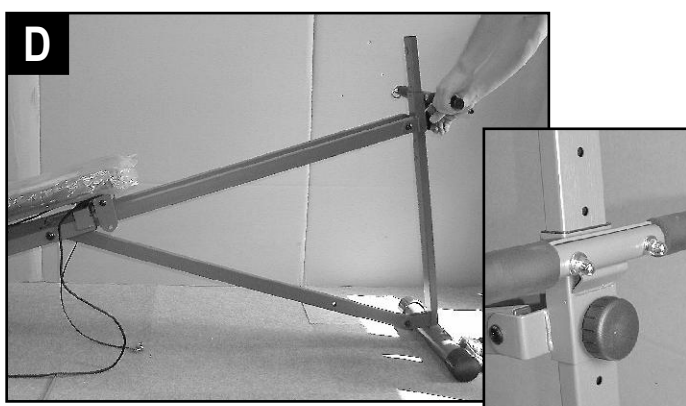

- Align the adjusting housing bracket to any of the holes on the upright support and fix with adjusting knob and tighten.

*** SHOULD YOU REQUIRE ANY ASSISTANCE REGARDING THIS PRODUCT PLEASE CONTACT YORK DIRECTLY. ***

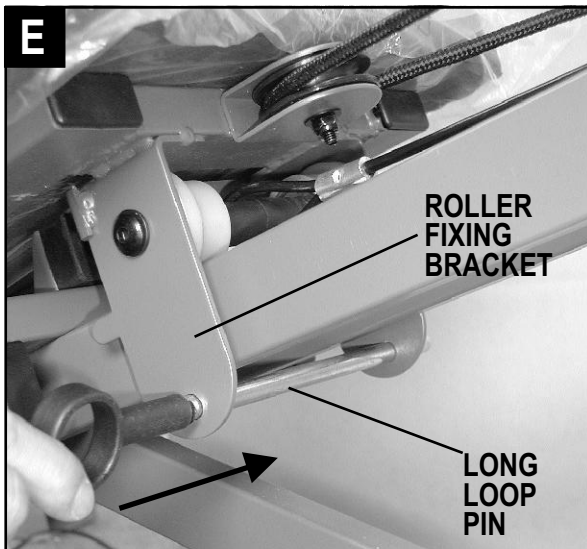

- Insert the long loop pin into the roller fixing bracket welded under the upholstery frame.

NOTE: MAKE SURE the two rollers on the assembly of the upholstery frame are in position as shown.

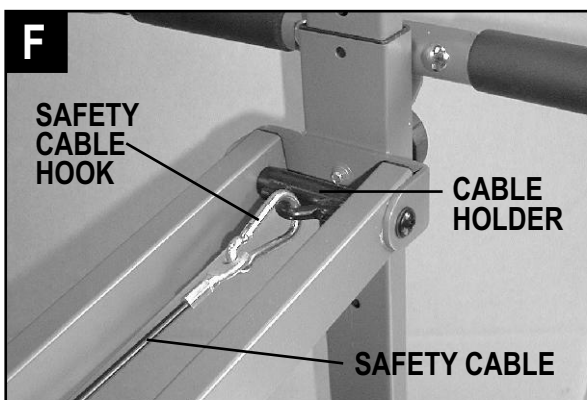

- Attach the safety cable hook to the cable holder on the main frame as shown.

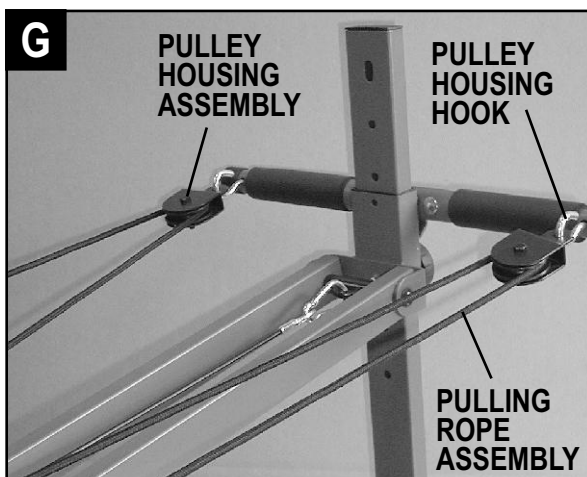

- Attach the pulley housing assembly onto the pulley housing hooks securely as shown.
- Recheck that all of the bolts are tightened securely for your safety and comfort. Before using your BODY GYM check and make sure the pulling rope assembly is moving smoothly.

REVERSE THESE STEPS FOR FOLDING AND STORING YOUR BODY GYM

- **MAKE SURE** the safety cable hook is detached from the cable holder before folding and storing your BODY GYM.
- As always, we recommend that you consult your physician before beginning any exercise program.
- Keep children away from your BODY GYM when not in use, and always keep children away from moving parts when your BODY GYM is in use.

* **SHOULD YOU REQUIRE ANY ASSISTANCE REGARDING THIS PRODUCT PLEASE CONTACT YORK DIRECTLY. ***

YORK BODY GYM

SAFETY GUIDELINES:

Please read and follow the following safety guidelines: Before beginning any exercise program, you should consult with your doctor. It is recommended that you undergo a complete physical examination. Read this owner's manual and follow the instructions.

- Assemble and operate the YORK BODY GYM on a solid, level surface.
- Keep the area behind the YORK BODY GYM clear.
- Always use your BODY GYM in adequate space e.g., at least 2 ft. (60cm) clearance on each side.
- Never allow children on or near your BODY GYM.
- You will need at least one person to help you assemble this unit, two would be better.
- Always check your BODY GYM before using it.
- Make sure all parts are assembled, and that the nuts and bolts are tightened.
- Do not use your BODY GYM if the unit is disassembled in any way.
- Keep hands away from moving parts.
- The weight limit for the BODY GYM is 225 lbs (100 kgs).
- Wear proper workout clothing: Do not wear loose clothing.
- Do not wear shoes with leather soles or high heels. Tie all long hair back.
- Don't rock the unit from side to side.
- Care should be taken when mounting and dismounting the unit.
- Do not use any accessories that aren't specifically recommended by the manufacturer, these might cause injuries or cause the unit to fail.
- Work within your recommended exercise level, do NOT work to exhaustion.
- If you feel any pain or abnormal symptoms, STOP YOUR WORKOUT IMMEDIATELY. Consult your physician immediately.
- Warm-up and stretching exercises are recommended before beginning your workout. After your workout, a cool-down exercise such as slow stretching or walking is also recommended.

The YORK BODY GYM is designed for the use and enjoyment of the serious trainer as well as the dedicated user. By following the above precautions and using good judgement and common sense, you will have safe and pleasurable exercise regime with the YORK BODY GYM.

CARE AND MAINTENANCE

Use a warm damp cloth with mild detergent to keep your YORK BODY GYM clean.

TOOLS REQUIRED

The tool enclosed in the carton is one multi-purpose spanner.

SHOULD YOU REQUIRE ANY ASSISTANCE REGARDING THIS PRODUCT PLEASE CONTACT YORK DIRECTLY.

U.K.	AUSTRALIA	U.S.A.
<p>YORK FITNESS</p> <p>HELP LINE (8:30am- 4:30pm) YORK BARBELL (U.K.) LTD. CHURCHILL WAY, DAVENTRY, NORTHANTS, NN11 4YB ENGLAND TEL: (01327) 701-824 FAX: (01327) 706-704 E-MAIL: helpdesk@yorkfitness.co.uk</p>	<p>YORK FITNESS</p> <p>HELP LINE (8:00am- 4:00pm) YORK BARBELL (AUST.) PTY. LTD. UNIT 1, LOT 2, SWAFFHAM ROAD, MINTO, N.S.W. 2566 AUSTRALIA TEL: (02) 9603-8444 FAX: (02) 9603-8555 E-MAIL: service@yorkfitness.com.au</p>	<p>YORK FITNESS</p> <p>HELP LINE (8:00am- 5:00pm) YORK BARBELL USA. 3300 BOARD ROAD. YORK, PA 17402 TEL: +1-717-767-6481 FAX: +1-717-764-0416 E-MAIL: info@yorkbarbell.com</p>

HOW YOUR BODY GYM WORKS

The principle behind the BODY GYM is to use your own body weight as the resistance. You are actually exercising directly against your own body weight, the desired percentage that you exercise against is determined by varying the angle of the upholstery seat and incline support frame.

You can select various heights on the upright, ranging from light on the lower levels to very heavy on the top levels.

RESISTANCE FORMULA

The table below is an approximate indication of the percentage of your body weight against which you are working.

<u>Upright Level</u>	<u>Upholstery Seat Pulley % of Body Weight Lifted</u>
1 - Minimum	25% of Body Weight
2	30% of Body Weight
3	35% of Body Weight
4	40% of Body Weight
5	45% of Body Weight
6 - Maximum	50% of Body Weight

To calculate the weight you are working against, multiply your weight by the level percentage- example: a 150 lb. person at Level 6 on Table 1 is $150 \times 50\% = 75$ lbs. being lifted.



*** SHOULD YOU REQUIRE ANY ASSISTANCE REGARDING THIS PRODUCT PLEASE CONTACT YORK DIRECTLY. ***

DESCRIPTION

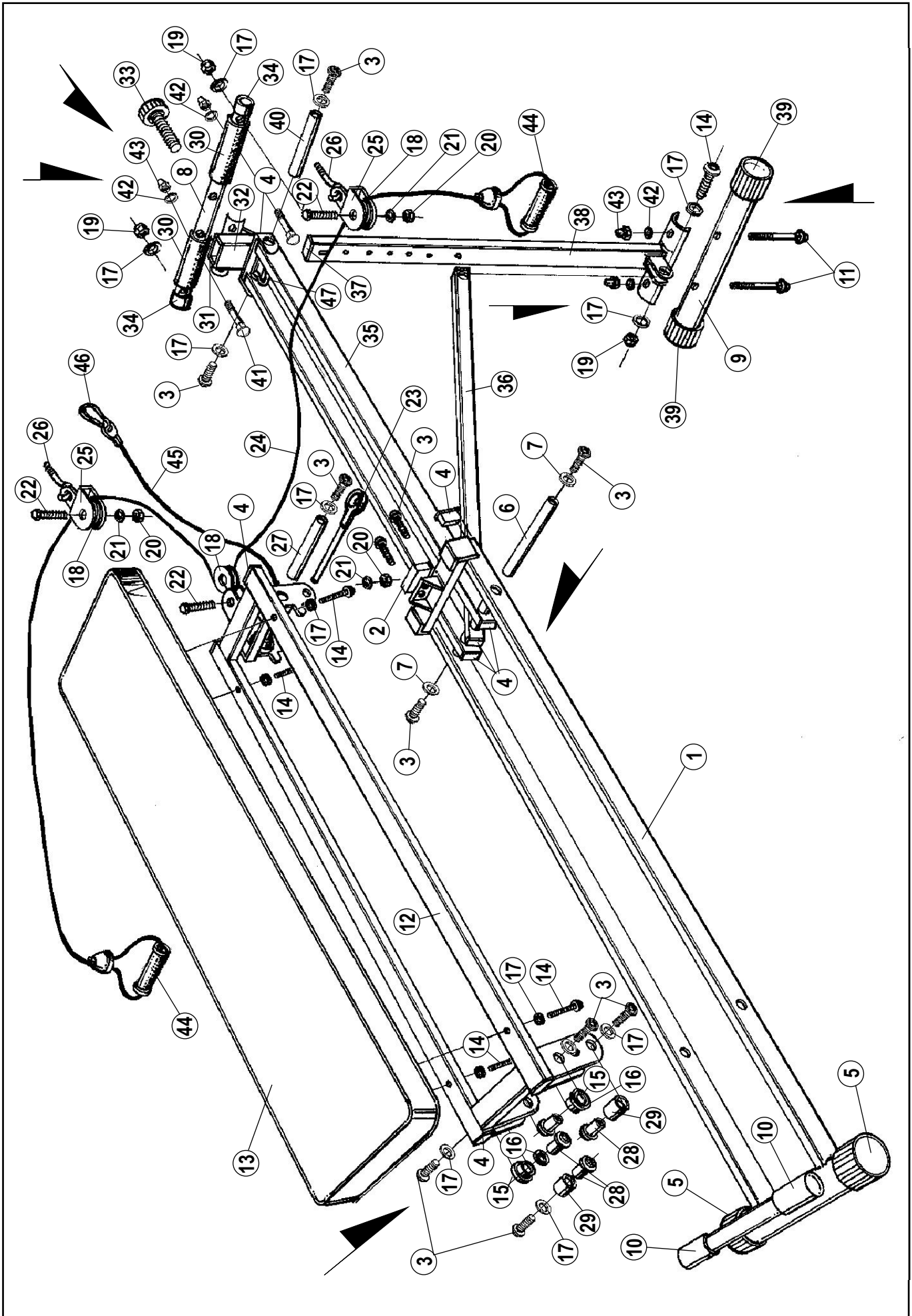

PARTS LIST

KEY NO.	PART NO.	Q'TY(PCS)	DESCRIPTION
1	5675-01	1	MAIN FRAME
2	5675-02	1	RUBBER STOPPER
3	5675-03	12	5/16" x 1/2" ALLEN HEAD BOLT
4	5675-04	12	END CAP
5	5675-05	2	STABILIZER END CAP
6	5675-06	1	MAIN PIVOT SHAFT
7	5675-07	2	8.5mm x 22mm WASHER
8	5675-08	1	PULLEY HOUSING SUPPORT
9	5675-09	1	FRONT STABILIZER
10	5675-10	2	FOOT STAND GRIP
11	5675-11	2	M8 x 70mm CARRIAGE BOLT
12	5675-12	1	UPHOLSTERY FRAME
13	5675-13	1	UPHOLSTERY
14	5675-14	5	5/16" x 1 1/2" ALLEN HEAD BOLT
15	5675-15	4	MOVING ROLLER
16	5675-16	8	BEARING
17	5675-17	15	5/16" x 3/4" WASHER
18	5675-18	3	PULLEY WHEEL
19	5675-19	3	5/16" LOCKNUT
20	5675-20	3	6mm LOCKNUT
21	5675-21	3	6.5mm X 16mm WASHER
22	5675-22	3	6mm x 32mm PULLEY BOLT
23	5675-23	1	LONG LOOP PIN
24	5675-24	1	PULLING ROPE ASSEMBLY
25	5675-25	2	PULLEY HOUSING
26	5675-26	2	PULLEY HOUSING HOOK
27	5675-27	1	AXLE SHAFT
28	5675-28	4	ROLLER AXLE
29	5675-29	4	PLASTIC BUSHING
30	5675-30	2	FOAM GRIP
31	5675-31	1	SLIDER INSERT
32	5675-32	1	ADJUSTING HOUSING
33	5675-33	1	ADJUSTING KNOB
34	5675-34	2	END CAP
35	5675-35	2	SUPPORT FRAME
36	5675-36	1	LINKAGE FRAME
37	5675-37	1	END CAP
38	5675-38	1	UPRIGHT SUPPORT
39	5675-39	2	MOVING WHEEL
40	5675-40	1	PIVOT SHAFT (SMALL)
41	5675-41	2	M8 x 40mm CARRIAGE BOLT
42	5675-42	4	8.5mm x 16mm CURVED WASHER
43	5675-43	4	M8 CAPNUT
44	5675-44	1	PULLING CABLE ASSEMBLY
45	5675-45	1	SAFETY CABLE
46	5675-46	1	CABLE HOOK
47	5675-47	1	CABLE HOLDER

YORK BARBELL LIMITED WARRANTY INFORMATION

- YORK BARBELL LTD. warrants this product to be free from defects in workmanship and material, under normal use and conditions, for a period of one year from date of original purchase.
- The warranty period can according to the type of product, model or parts concerned and may vary according to country.
The standard warranty for the YORK BODYGYM is 12 months.
If you require further detail, please contact the York office in your location (see below).
- This warranty covers the product for home/domestic use only and not for commercial or rental usage.
- York Barbell Ltd will not be responsible for damages or failures that occur as a result of improper assembly, adjustment or failure to operate the product as detailed in the manual.
- This warranty does not cover accidental damage, misuse, abuse, lack of reasonable care for the product, freight damage or alterations or repairs not made by York Barbell Ltd or a recommended service centre.
- During the warranty period, York Barbell will at no additional charge replace parts or repair the product if it becomes defective, malfunctions or otherwise fails to conform to this warranty under usual, non commercial use.
- In repairing the product, York Barbell Ltd may replace defective parts and reserves the right to use serviceable used parts that are equivalent to new parts in performance.
- In the unlikely event of a problem occurring, please contact the York office in your location (see below). Please have your proof of purchase ready.
- If the problem cannot be fixed by sending parts, you will need to arrange to send the goods to a York authorised repair centre. You must prepay any shipping charges and you are responsible for insuring any product or part shipped or returned. Returns will not be accepted without written authorisation by York Customer Service Department.

WARRANTY REGISTRATION

- It is strongly recommended that you complete the warranty registration document and return it to your authorized local YORK Dealer.

U.K.	AUSTRALIA	U.S.A.
<p align="center">YORK FITNESS</p> <p>HELP LINE (8:30am- 4:30pm) YORK BARBELL (U.K.) LTD. CHURCHILL WAY, DAVENTRY, NORTHANTS, NN11 4YB ENGLAND TEL: (01327) 701-824 FAX: (01327) 706-704 E-MAIL: helpdesk@yorkfitness.co.uk</p>	<p align="center">YORK FITNESS</p> <p>HELP LINE (8:00am- 4:00pm) YORK BARBELL (AUST.) PTY. LTD. UNIT 1, LOT 2, SWAFFHAM ROAD, MINTO, N.S.W. 2566 AUSTRALIA TEL: (02) 9603-8444 FAX: (02) 9603-8555 E-MAIL: service@yorkfitness.com.au</p>	<p align="center">YORK FITNESS</p> <p>HELP LINE (8:00am- 5:00pm) YORK BARBELL USA. 3300 BOARD ROAD. YORK, PA 17402 TEL: +1-717-767-6481 FAX: +1-717-764-0416 E-MAIL: info@yorkbarbell.com</p>
CANADA	TAIWAN	Authorized Dealer
<p align="center">YORK FITNESS</p> <p>HELP LINE (8:30am- 4:30pm) YORK BARBELL CO. LTD. 1450 S. SERVICE ROAD WEST, OAKVILLE (TORONTO), ONTARIO, CANADA L6L 5T7 TEL: (905) 827-6362 FAX: (905) 827-9593</p>	<p align="center">YORK FITNESS</p> <p>HELP LINE (9:00am- 6:00pm) YORK FITNESS (TAIWAN) LTD. ROOM A2 4F, NO.51, GONG-YI ROAD, SEC. 2, TAICHUNG CITY, TAIWAN TEL: +886-4-2319-3448 FAX: +886-4-2319-3449 E-MAIL: yorktwn@ms25.hinet.net</p>	

WARRANTY REGISTRATION

IMPORTANT: Please complete and return this page, with a copy of your receipt, to your local YORK Dealer within 14 days. Alternatively, you can register your warranty on-line - please visit www.yorkfitness.com

Which product did you buy? _____

Where from (name of retailer)? _____

Date Purchased _____

Serial / Batch No _____

Name (Mr/Miss/Mrs) _____

Address _____

Telephone Number _____

E-mail address _____

Please help us to improve our products and services by answering the following questions:

How did you buy this product?

In a shop _____
Mail order catalogue _____

Over the internet _____
Other, please specify _____

Why did you choose this product (tick all that apply)?

Discounted price _____
York brand name _____
Best specification at the price you wanted to pay _____
Word of mouth recommendation _____
Sales staff recommendation _____
Received as a present _____

What prompted you to buy fitness equipment (tick all that apply)?

Replacing old equipment _____
Saw an advert with big price savings _____
Medical advice _____
Thought it was about time to get fit _____
Want to look good _____

Did you search the web before buying this product?

Yes _____
No _____

Do you have access to a PC at home?

Yes _____
No _____

Were you aware of York before you bought this product?

Yes _____
No _____

How would you rate the product you have just purchased (1 = poor, 10 = excellent)?

Quality _____
Looks _____
Usability _____
Instruction manual _____
Ease of assembly _____

Are you a member of a gym or fitness club?

Yes _____
No _____

On average, how many times a week do you exercise / work out?

Under 18 _____
18 - 29 _____
30-39 _____
40-49 _____
50+ _____

0 _____
1 - 2 _____
2 - 3 _____
4 or more _____

Any other comments

This information will be held by York Barbell Ltd and will not be passed onto third parties. Please tick this box if you would not like to receive further information from York Barbell

YOUR WARRANTY IS ONLY VALID IF YOU CAN PROVIDE PROOF OF THE ORIGINAL PURCHASE.

This can be the receipt, invoice, delivery note or internet confirmation.

YORK[®]
FITNESS

PLACE
STAMP
HERE

PARTS ORDER FORM

Enclose a check or money order
with this form for replacement parts.

Date of purchase -----

Name of location where purchased -----

Model number -----

Last name, First name -----

Telephone number -----

Address ----- City ----- State ----- Zip/Postcode -----

Part No.	Q'ty	Part Description	Unit Price	Total
Total value of order				

Send your order to:

**YORK BARBELL (AUST.) PTY. LTD.
UNIT 1, LOT 2, SWAFFHAM ROAD,
MINTO N.S.W. 2566
AUSTRALIA**

**YORK BARBELL (U.K.) LTD.
CHURCHILL WAY,
DAVENTRY, NORTHANTS,
ENGLAND, NN11 4YB**

**BERNSPORT (1995) LTD.
PO BOX 33-973 TAKAPUNA,
AUCKLAND NEW ZEALAND**

**PLACE
STAMP
HERE**

YORK[®]
FITNESS

**PLACE
STAMP
HERE**

**PLACE
STAMP
HERE**