

diamond
sit-up & flat bench

owner's manual

yorkfitness.com

YORK[®]
FITNESS



Congratulations on purchasing a bench from York Fitness.

You have chosen a high quality, safe and innovative piece of equipment as your training partner and we are certain it will keep you motivated on the way to achieving your personal fitness goals.

Please take the time to read this owner's manual as it will help you to get the most out of your new bench. For more information visit www.yorkfitness.com

contents

safety information	04
customer support	05
assembly instructions	06
user instructions	12
- sit-up adjustment	
working out with your bench	14
your warranty	15
exploded diagrams and parts list	16



safety information

PLEASE READ THIS INSTRUCTION MANUAL BEFORE YOU BEGIN ASSEMBLY. GREAT CARE HAS BEEN TAKEN TO DESIGN THESE INSTRUCTIONS AND FOLLOWING THEM WILL HELP YOU WITH QUICKER ASSEMBLY AND MINIMISE THE RISK OF INJURY

YOU ARE RESPONSIBLE FOR YOUR OWN SAFETY - THIS LIST IS NOT EXHAUSTIVE.

- Assemble the product on a level surface
- You will need at least one person to help you assemble this unit.
- Always use the product on a level surface, ensure that the product is stable before use.
- Always ensure that the equipment has adequate space on each side and front (the back can be near to a wall).
- Replace defective components immediately, and/or keep the equipment out of use until it is repaired.
- Use only the adjustment settings as described in the instructions. Always use the correct adjustment pin/fixing.
- Always check that any pins / fixings are tight and secure before use and / or after adjustment.
- Never leave any adjustment devices projecting from the product.
- Always consult your doctor before undertaking any exercise program.
- Always wear suitable clothing and footwear e.g. tracksuit / shorts / training shoes
- Remove all personal jewellery before exercising.
- Ensure you warm-up well before using the equipment as this will help to prevent muscle strain.
- After eating, allow 1-2 hours before exercising as this will help to prevent muscle strain.
- Injuries to health may result from incorrect or excessive training.
- Never overload the equipment - the maximum user load is displayed below and on the product label.
- We recommend that you do not lift weights alone. There should be somebody there to assist you.
- Never use the equipment in any other manner other than the ways explained in these instructions and/or any wall-chart supplied.
- Parents and others in charge of children should be aware of their responsibility, because the natural play instinct and the fondness of experimenting of children can lead to situations and behaviour for which the training equipment is not intended
- If children are allowed to use the equipment, their mental and physical development and above all their temperament should be taken into account. They should be controlled and instructed in the correct use of the equipment.
- The equipment is under no circumstances suitable as a children's toy.
- Children should not be allowed on, or around the equipment - especially when it is not in use.

Safety Standards

This bench meets the requirements of British and EU safety standards EN957 parts 1 and 4. Therefore the product carries the following mark:



Maximum Weight Limits

Flat / Incline: 100kg User + 100kg Weight

Tools and consumables

Item 33 - 2x Spanner (13 & 17mm)

Item 34 - 2x Allen Key (6mm) & Screw Driver

This product is not suitable for therapeutic purposes.



It is important that you keep these instructions for future reference.

Care & Maintenance

- Always place the equipment in a dry environment.
- Use a warm, damp cloth to keep the product clean.
- The safety level of the equipment can be maintained only if it is regularly examined for damage and wear, at least once a week is recommended. This includes any nuts, bolts, moving parts, bushes etc.
- Ensure that all fixings are tight before use.
- Always replace damaged / worn components with original parts from the manufacturer.

Protect the environment by not disposing of this product with household waste (2002/96/EC).
Check your local authority for recycling advice and facilities (Europe only).

Customer Support

Should you require any assistance regarding this product please gather the following information, and then contact us using the details below:

1. Serial / batch no. - this can be found on a sticker which is located on the metal framework of the product.
For future reference, please write down this batch number in the space provided below.
2. Original purchase date
3. Place of purchase
4. Information about the place and conditions of use
5. Precise description of the issue/defect

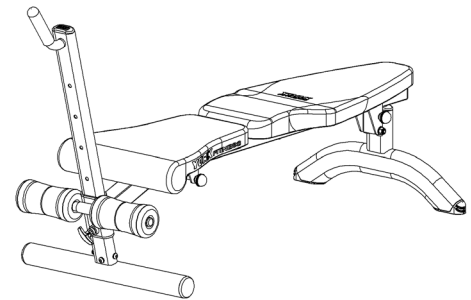

Your Batch/Serial No. is:

Contact Us

ENGLAND

York Barbell (UK) Ltd. York Way, Daventry, Northants, England NN11 4YB
Tel: (01327) 701800 Fax: (01327) 706704 email: helpdesk@yorkfitness.co.uk

AUSTRALIA

Unit 1, Lot 2, Swaffham Road, Minto, N.S.W. 2566 Australia
Tel: (02) 9603 8333 Fax: (02) 9603 8555 email: service@yorkfitness.com.au

OTHER LOCATIONS

Please see website - www.yorkfitness.com

assembly instructions

1. Before you start

1. **Prepare your work area** - it is important you assemble the product in a clean and uncluttered space.

2. **Work with a friend** - we recommend you have someone assist you with the assembly as some of the components are quite heavy.

3. **Open the carton** - checking any warnings on the carton and make sure you have it the right way up.

4. Unpack the carton

a. Remove all the parts and lay them out on the floor

b. Make sure you have the following parts:

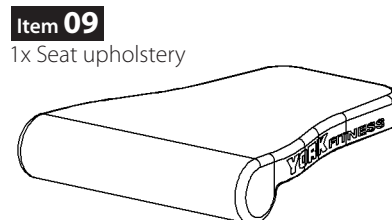
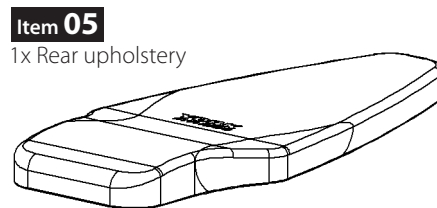
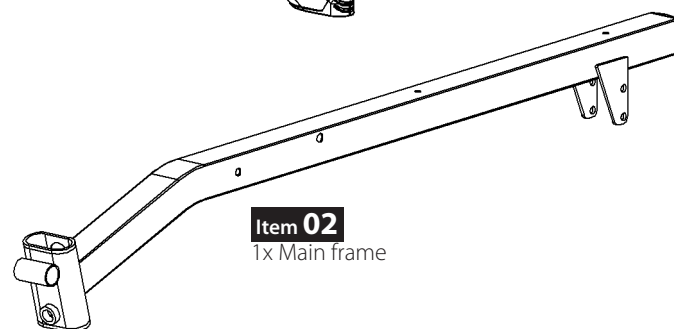
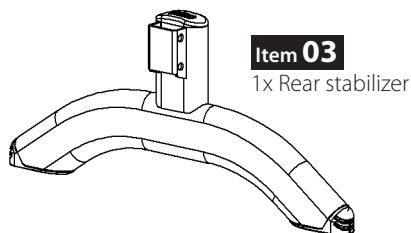
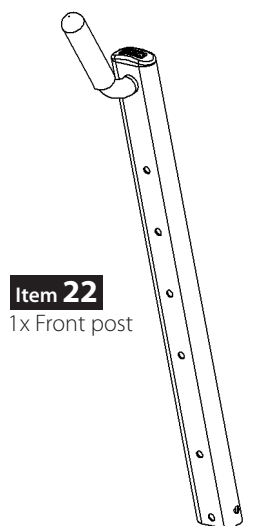
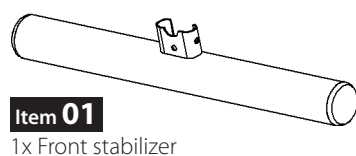

Fixings



This bench takes up a floor space of 1590mm by 592mm and weighs 20kg



If you suspect you may have some parts missing, please contact us before going back to your retailer. Refer to the Customer Support section on page 5 for contact details.

2.

FIXINGS:

Item 12

1x Pull/twist plunger



Item 28

2x HH Bolt M8 x 65mm





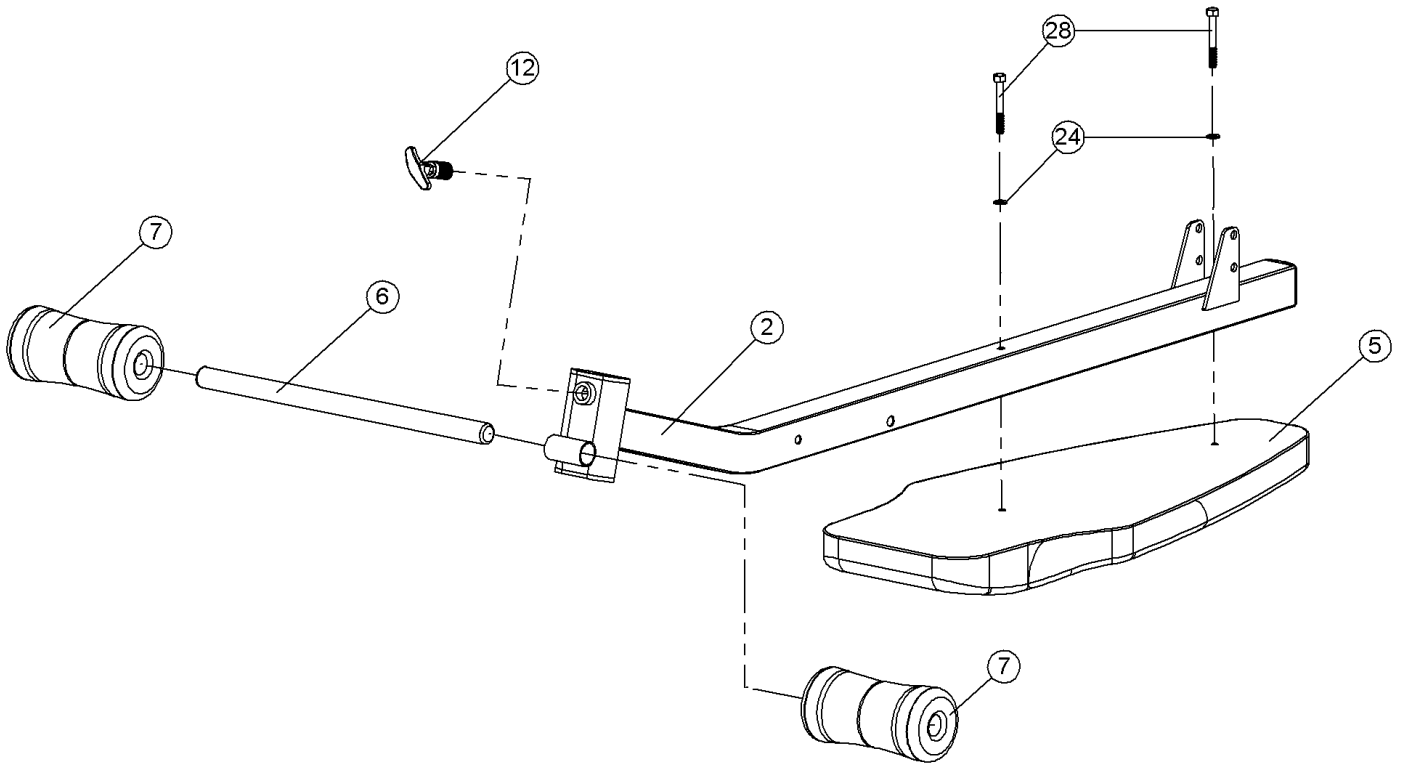

Item 24

2x Washer M8



3.

FIXINGS:

Item 24 6x Washer M8		Item 26 1x Pivot rod Ø12 x L:136mm	
Item 25 2x Allen bolt M8 x 20mm		Item 27 4x HH Bolt M8 x 42mm	

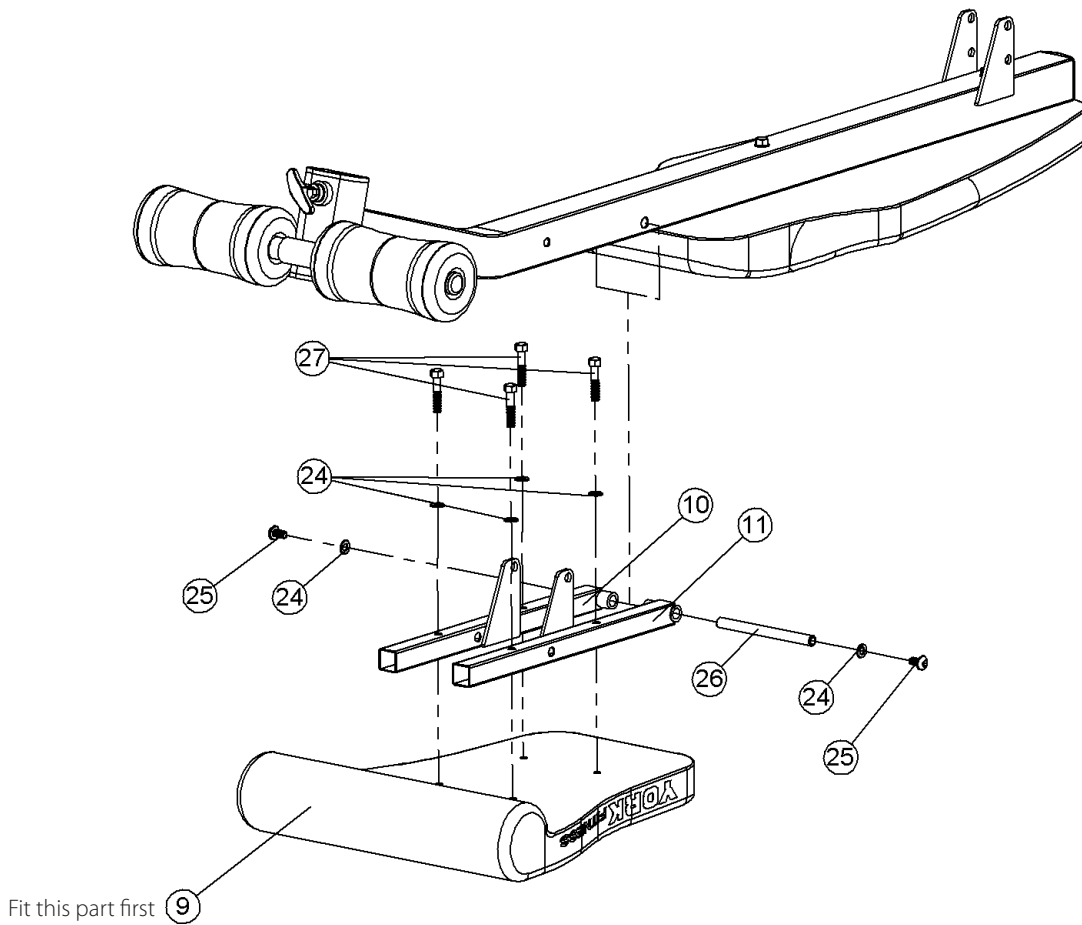

4.

FIXINGS:

Item 15

1x Pull pin Ø10 x 97mm

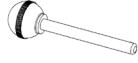

Item 29

2x Washer M10



Item 31

1x HH Bolt M10 x 75mm



Item 20

1x Pull pin Ø10 x 72mm



Item 30

1x Nyloc nut M10

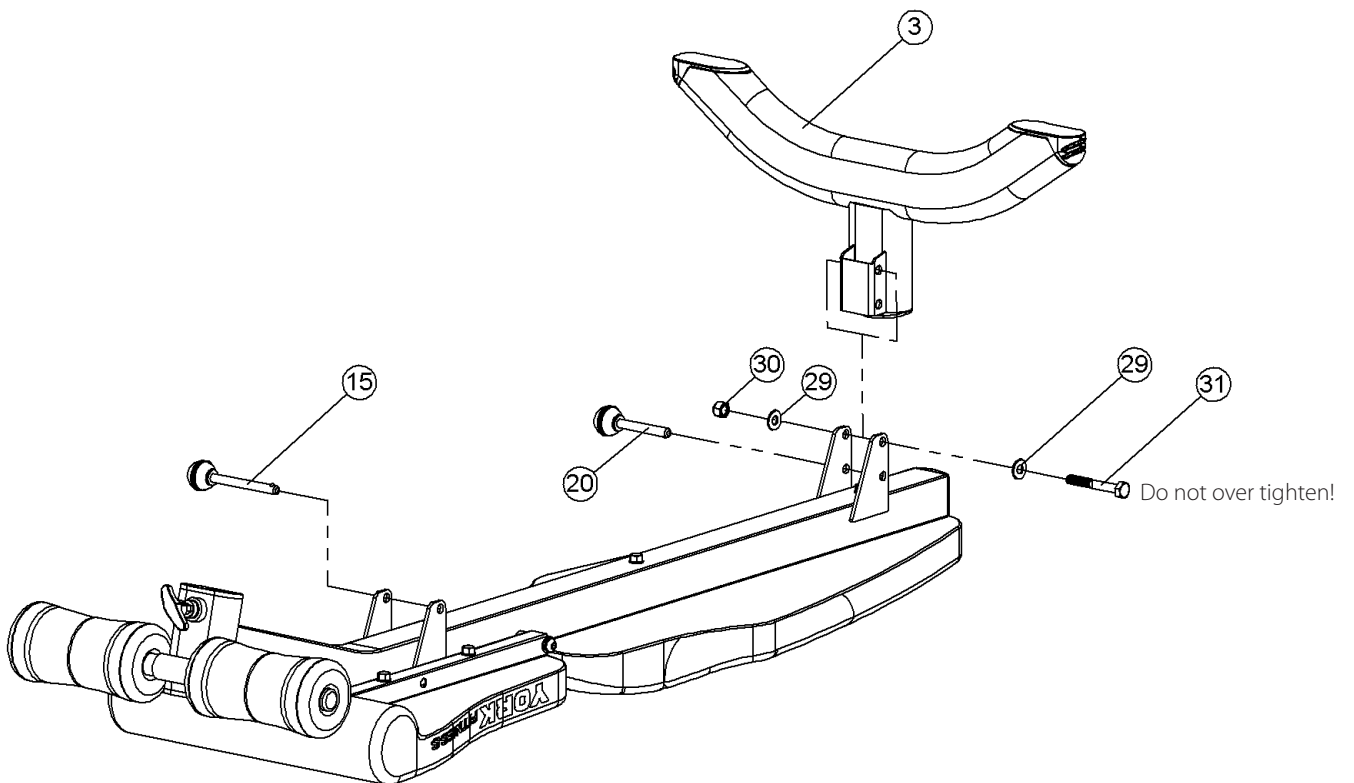

5.

FIXINGS:

Item 24

3x Washer M8



Item 25

3x Allen bolt M8 x 20mm

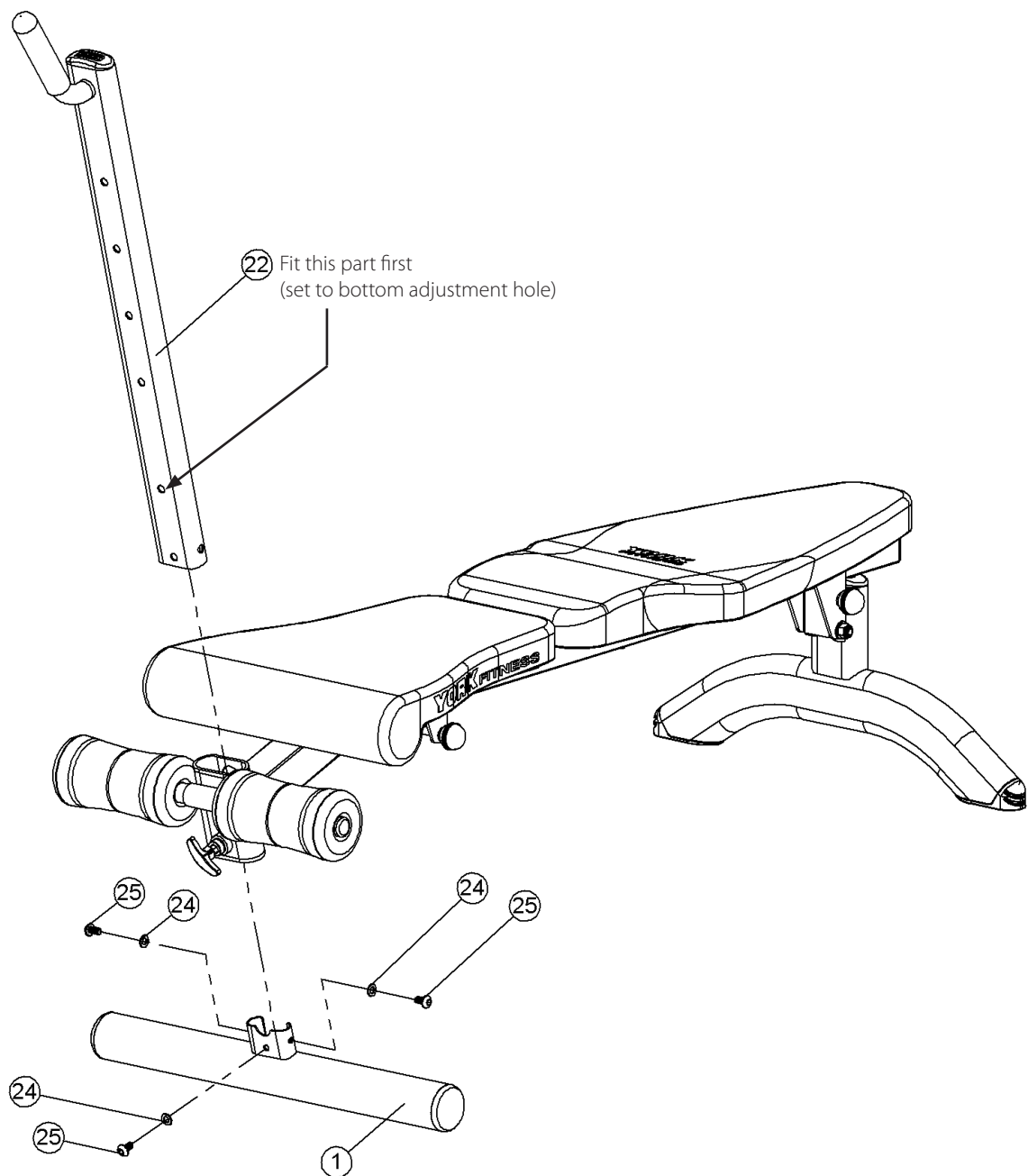

6. Final Checks

Your bench is now assembled. Please make the following final checks before you use it for the first time:

- Make sure all screws / bolts are tightened
- Make sure you have positioned it on a flat, level surface

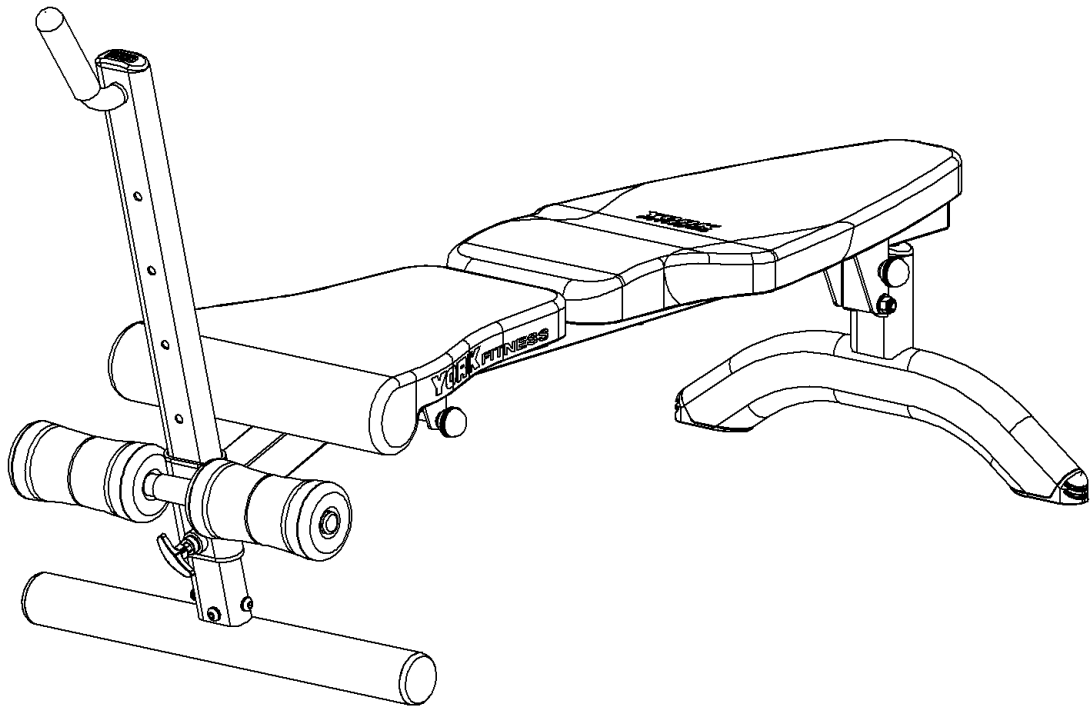

user instructions

sit-up adjustment

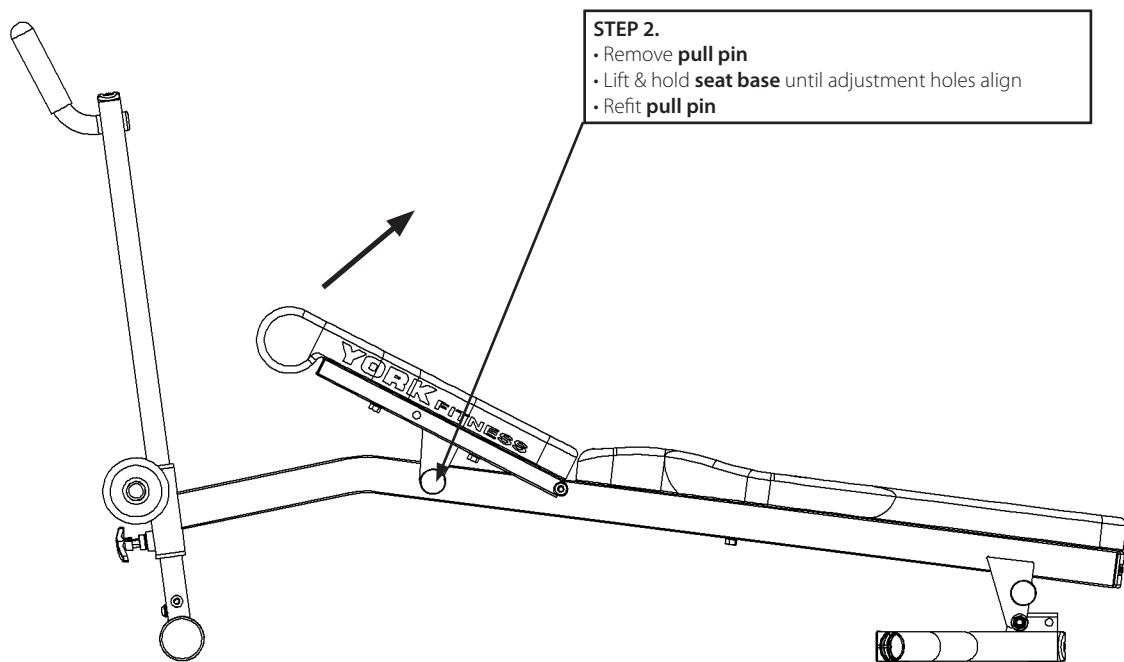
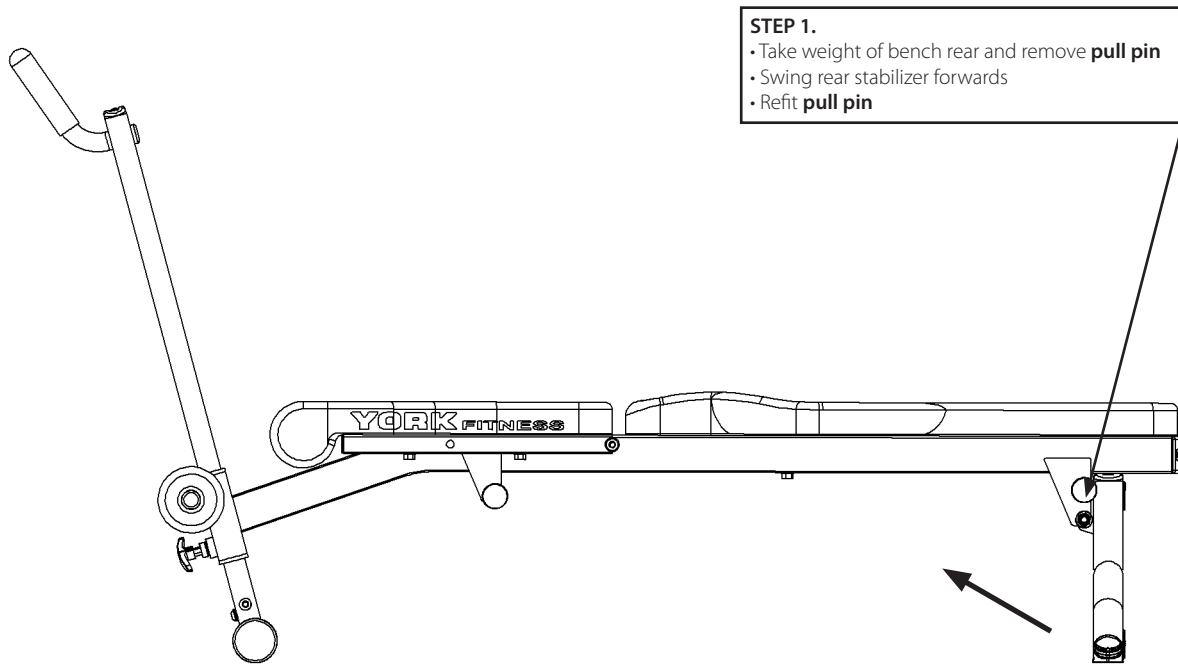

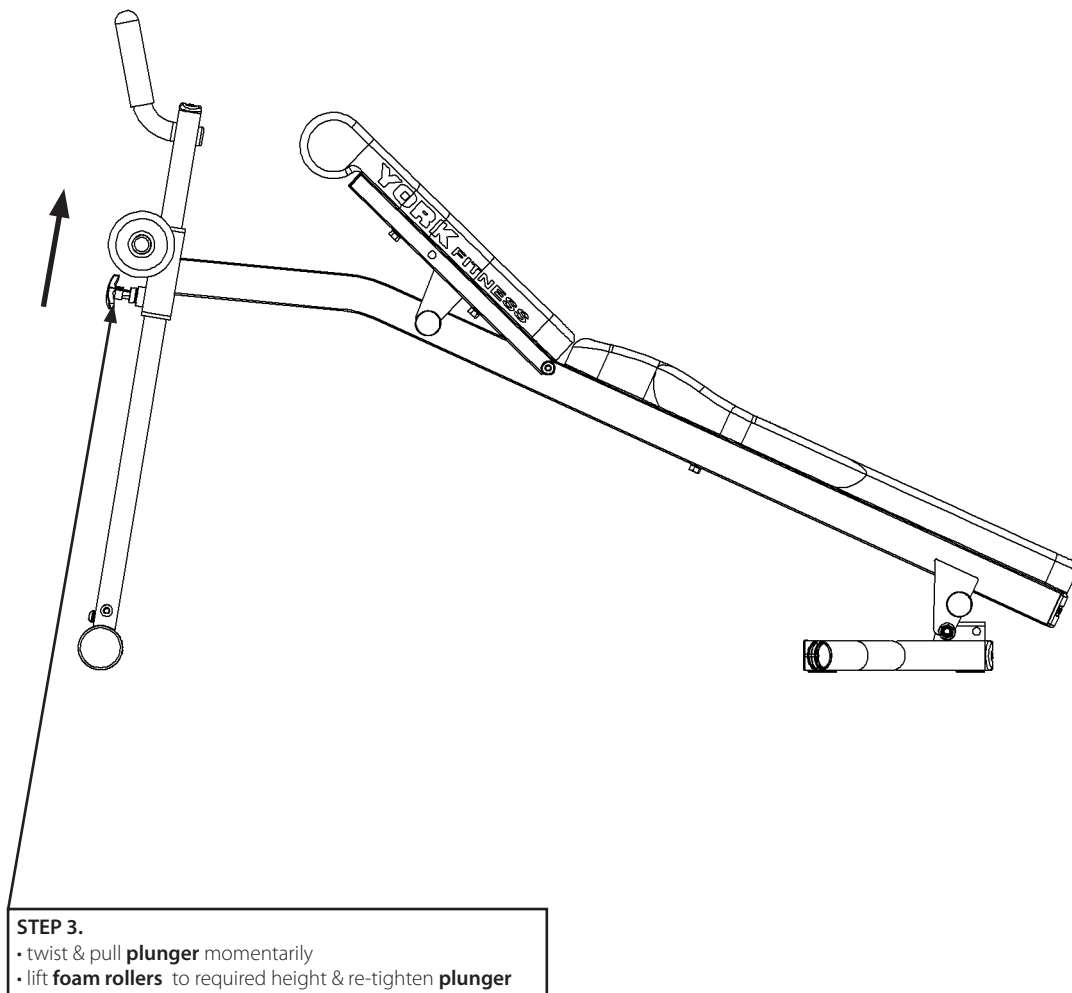

flat adjustment

Reverse above procedure to set to the flat position
Ensure rear stabilizer is vertical before inserting pull pin

exercising with your bench



Always consult your doctor before undertaking a new exercise regime

If you experience nausea, dizziness or other abnormal symptoms during exercise, stop at once and consult your doctor

Starting your workout

Begin each workout with a warm up session – the purpose of this is to raise your heart rate slightly and mobilise major joints to prevent strains, pulls and cramps.

- Perform some gentle stretching
- Do light cardiovascular exercise (ie cycle) for approx 5-10 mins
- 'Dry-run' one exercise per body part without using weights to ensure muscles and joints are warm

Finishing your workout

End each workout with a warm down session – the purpose of this is to lower your heart rate slightly and to prevent strains, pulls and cramps.

- Perform 3-5 minutes of light cardiovascular work to gradually lower heart rate and reduce body temperature back towards resting levels
- Exercise should be rhythmical and of gradually decreasing intensity.
- Stretch all the major muscle groups – this will aid recovery and return the muscles to their normal length

Correct exercising form

- Hold weights with a comfortable grip (avoid gripping too tightly)
- Stand, sit or lie as described below, paying particular attention to your abdominal muscles which help support your back:
 - Standing - For most standing exercises use a split foot position (feet apart with one foot forward hips remain square to front), stand tall and pull abdominals firmly in
 - Seated – Feet parallel, hip width apart, sit tall and pull abdominals tightly in
 - Lying down – Always ensure back to bench and abdominals tightly pulled in
- Ensure joints remain soft (not locked out) and movements are carried out in a smooth and continuous way. (Each repetition should take you approximately a slow count of 4 to do)
- Avoid using 'momentum' and instead focus on the muscles you are working - throwing weights with poor technique increases the risk of injury and reduces training benefits
- Use full range of movement for each repetition performed
- Do not hold breath whilst training, instead exhale on the hardest phase of the exercise and inhale on the easier phase eg) Bicep Curl – exhale as you curl dumbbell towards shoulder and inhale as you return the weight to the start position

Choosing your weights

Start with a weight you can perform 12 repetitions without crossing the line from 'challenged' to 'struggle'. If you cannot maintain correct technique, the weight is too heavy!

Gradually increase the weight as you become stronger and more practiced.

Training for increased muscle size

- Keep your sets between 8 – 12 repetitions
- Repeat each individual exercise 2 or 3 times increasing weight slightly and decreasing repetitions ie. 1st set 12 repetitions, 2nd set 10 repetitions, 3rd set 8 repetitions
- Rest for 1 minute between sets

Training for shape/definition

- Sets should be 12 – 15 repetitions
- Repeat each individual exercise 1 or 2 times with sets of between 12 - 15 repetitions
- Rest for 1 minute between sets



Please see the accompanying wallchart for guidelines on how to perform specific exercises

your warranty

This product is supplied with a standard warranty as follows:

- Lifetime frame
- 12 month other parts
- 12 months labour

This product is warranted for use in a home, personal, family or household environment

Please Note: Warranty details may vary from one market area to another

Warranty Terms

York Barbell (U.K.) Ltd. warrants that the Product you have purchased from an authorised York reseller is free from defects in materials and workmanship. The Warranty is valid subject to normal and reasonable use in the environment as described above, and correct assembly of the product during the warranty period. The warranty period extends to the original purchaser only. It is not transferable to anyone who subsequently purchases the Product from you.

The warranty excludes normal wear and tear on parts.

Your sales receipt, showing the date of purchase of the product, is your proof of the date of purchase.

This warranty becomes valid only if the Product is assembled / installed according to the instructions / directions included with the product. This warranty does not extend to any product that has been damaged or rendered defective: (a) as a result of accident, misuse, abuse or lack of reasonable care; (b) by the use of parts not manufactured by York Barbell or sold by York Barbell; (c) by modification of the product; (d) as a result of service by anyone else other than York Barbell or an authorised York Barbell warranty service provider.

During the warranty period York Barbell will at no additional charge provide replacement part(s) or repair the product (at York Barbell's option) if it becomes defective, malfunctions or otherwise fails to conform with this warranty under normal, non-commercial, personal, family or household use. In repairing the product, York Barbell may replace defective parts or at the option of York Barbell, use serviceable used parts that are equivalent to new parts in performance. All exchanged parts and products replaced under this warranty will become the property of York Barbell. York Barbell reserves the right to change manufacturers of any part to cover any existing warranty.

If the product must be returned, you must return the Product or defective part to York Barbell in its original container (or equivalent) with Proof of Purchase. Any evidence of alteration, erasing or forgery of proof of purchase documents will be cause to void this warranty. You must prepay any shipping charges and you are responsible for insuring any product or part that is returned. Should any product submitted for warranty service be found to be ineligible, an estimate of repair cost will be furnished and the repair will be made if requested, upon York Barbell's receipt of payment or acceptable arrangement of payment. Under no circumstances will returns be accepted without return authorisation by our Customer Service department.

To obtain warranty service you must and provide the following information:

Name of Product, Product Code, Batch No, Date Purchased, and Nature of fault or part number required.

Neither dealer of this product nor any retail establishment selling this product has any authority to make any warranties or to promise remedies in addition to, or inconsistent with, those stated above. This warranty does not affect your statutory rights.

Please note that warranty terms may vary from one market area to another

exploded parts

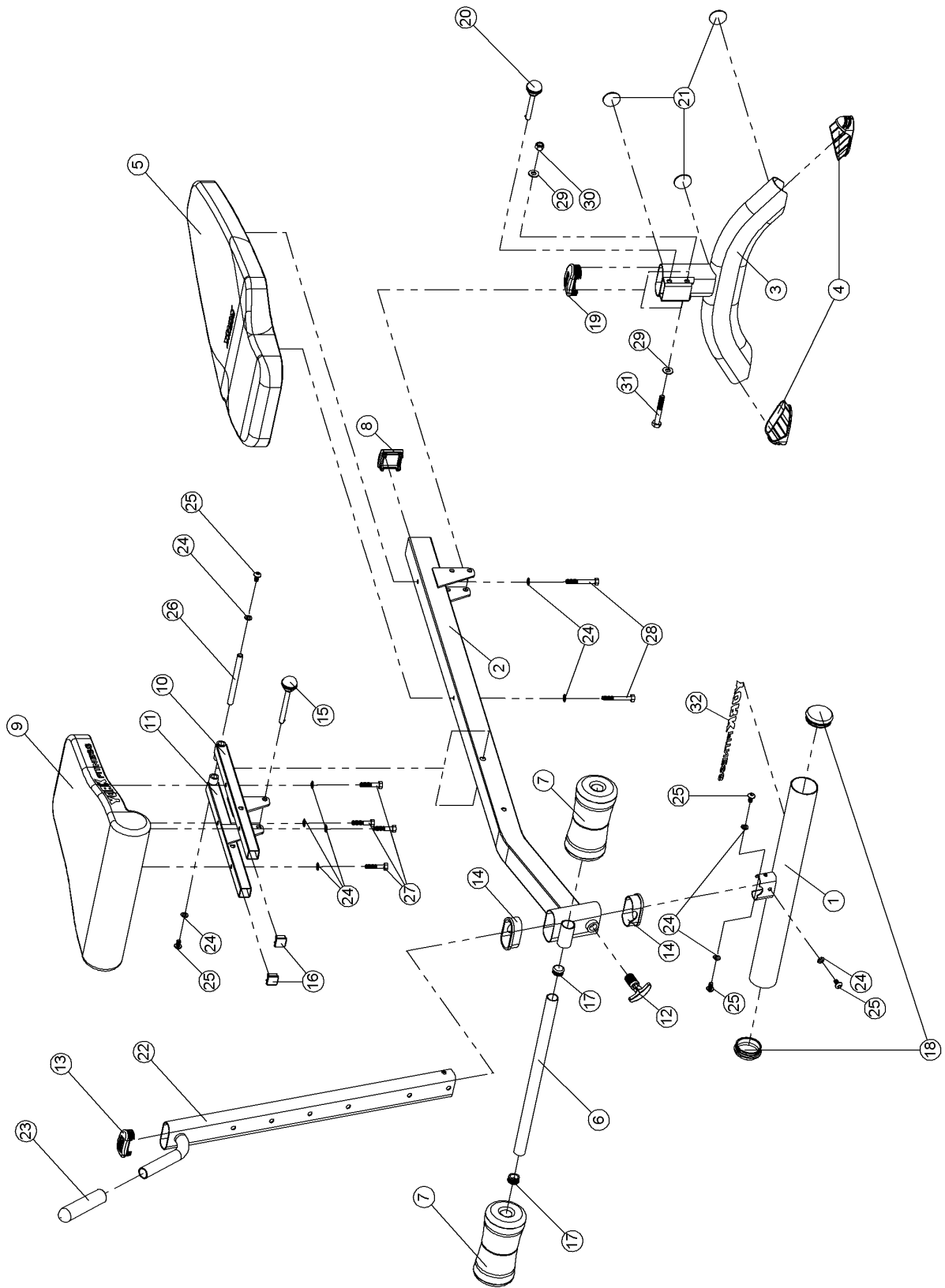

Item	Qty	Part no.	Part Description
1	1	YKA00259g10	Front stabilizer assembly
2	1	YKA00260g5	Main frame assembly
3	1	YKA00261g10	Rear stabilizer assembly
4	2	YKF20423o1	Internal angled foot
5	1	YKF30060q30	Rear upholstery
6	1	YKP00227g10	Roller mount tube
7	2	YKF30062b1	Foam Rollers (shaped)
8	1	YKF20416b3	Square Radius Internal End Cap (SQ50mm / 2mm tube)
9	1	YKF30061q30	Seat upholstery
10	1	YKA00262g10	Left seat support assembly
11	1	YKA00263g10	Right seat support assembly
12	1	YKF50011o1	Pull/twist plunger
13	1	YKF20424b3	Flat Oval Internal End Cap (70 x 30mm)
14	2	YKF20421b3	Flat oval plastic reducer (40x80 > 70x30mm)
15	1	YKF10467o1	Pull pin Ø10 x 97mm
16	2	YKF20417b3	Square Flat Internal End Cap (SQ - 25mm)
17	3	YKF20010b3	Round Internal End Cap (Ø25.4mm)
18	2	YKF20426o1	Round Domed Internal End Cap (Ø60mm x 2mm tube)
19	1	YKF20425b3	Flat Oval Internal End Cap (80 x 40mm)
20	1	YKF10468o1	Pull pin Ø10 x 72mm
21	3	YKF30063g14	Adhesive Rubber Pad (Ø38mm)
22	1	YKA00264g10	Front post assembly
23	1	YKF20001b5	Handgrip (OD-31.8 x L130mm)
24	11	YKF10398z1	Flat washer (M8)
25	5	YKF10046z1	Allen head bolt (M8 x 20mm)
26	1	YKP00228z1	Pivot rod (Ø12 x 136mm)
27	4	YKF10462z1	Hex head bolt (M8 x 42mm)
28	2	YKF10042z1	Hex head bolt (M8 x 65mm)
29	2	YKF10013z1	Flat washer (M10)
30	1	YKF10012z1	Nyloc nut (M10)
31	1	YKF10012z1	HH Bolt M10 x 75mm
32	1	YKF50180q30	Decal "York Fitness" (290 X 23mm)
Tools			
33	2	YKF70026	Spanner (13 & 17mm)
34	2	YKF70028	Allan Key (6mm) & Screw Driver