

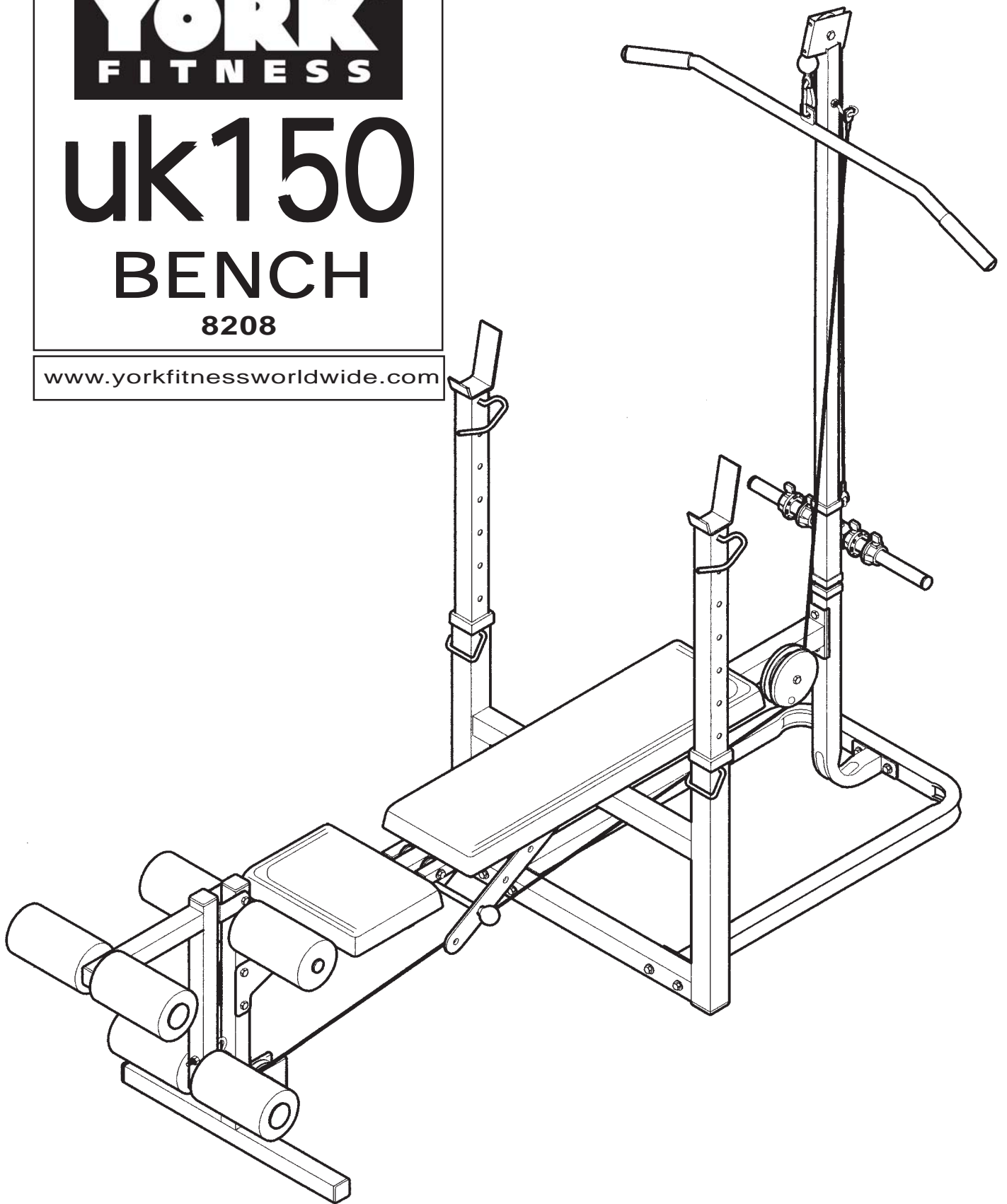

# uk150 BENCH

8208

[www.yorkfitnessworldwide.com](http://www.yorkfitnessworldwide.com)



# INSTRUCTION MANUAL

5/5/04

## BEFORE ASSEMBLY

This must be read before you start assembling this unit. Great care has been taken in design and how to assemble this unit. All bags of nuts and bolts have been packed with ease of assembly in mind. You must follow the assembly instructions exactly as outlined.

**You will need at least one person** to help you assemble this unit. Assemble this unit starting at the beginning and work to the end. The assembly instructions are set out so that you are only doing one section at a time, therefore you will finish one section and move on to the next. Do **not** do what most people do, when all else fails they read the assembly instructions. If something is missing when assembling this unit, you must notify us of the part number of the exact nut, bolt or part that is missing. To help you assemble this unit we have used line drawings. Check the line drawings for the exact positioning of the parts.

This unit will need to be checked at least once a week for nuts and bolts that can work loose, upholstered pieces working loose and wear on pivot assemblies.

**WARNING: YOU ARE RESPONSIBLE FOR YOUR OWN SAFETY!!**

**If the box containing the parts for the uk150 BENCH was unopened** when you purchased it and there is a shortage, please notify us by mail and send a copy of your receipt. If the box was opened and there is a shortage, the dealer is responsible. Please indicate to us the part number which is missing and we will return the missing part by return mail.

## NOTE:

Assemble frame with bolts and nuts finger tight at first. This equipment has been supplied with some NYLOC (LOCK) Nuts. It is essential that the nuts are tightened onto the bolts so that the bolt penetrates through the nylon insert in the nut locks up against the tubing

## TOOLS NEEDED TO ASSEMBLE uk150 BENCH

- 1 x 13mm spanner
- 1 x 14mm spanner
- 1 x slotted screwdriver
- 1 x rubber mallet (for end caps)
- 1 x adjustable spanner

**This bench should be assembled finger tight in the beginning to allow for proper alignment.**



Distributed by:

**YORK BARBELL (U.K.) LTD.**

CHURCHILL WAY, DAVENTRY,  
NORTHANTS, NN11 4YB, ENGLAND  
**GENERAL ENQUIRIES**

TEL: (01327) 701800

**CUSTOMER SERVICE HELPLINE**

TEL: (01327) 701824

FAX: (01327) 706704

E-MAIL: [helpdesk@yorkfitness.co.uk](mailto:helpdesk@yorkfitness.co.uk)

[www.yorkfitnessworldwide.com](http://www.yorkfitnessworldwide.com)

## WARNING:

It is important that you do not destroy these instructions, they will need to be kept for further reference

**WARNING: YOU ARE RESPONSIBLE FOR YOUR OWN SAFETY!!**

## WARNINGS:

1. Always consult your doctor before undertaking any exercise program.
  2. Ensure that all nuts and bolts are fully tight before using any exercise equipment.
  3. Always wear suitable clothing and footwear e.g. tracksuit and training shoes.
  4. Children should not be allowed on or around the machinery or equipment, even when not in use.
  5. After eating allow 1 to 2 hours prior to exercising.
  6. Always warm up well before exercising as this will prevent straining muscle.
  7. Always read and follow the manufacturers assembly and user instructions.
  8. Remove jewellery, rings, chains and pins before exercising.
  9. Check for full engagement of locking pins.
  10. Check that any of the adjustment devices are not projecting.
  11. Injuries to health may result from incorrect or excessive training.
  12. Always use your bench on a flat level surface.
  13. Always use your bench in adequate space e.g. at least 2ft. (60cm) clearance on each side.
  14. We recommend you never lift weights alone. There should always be someone available to assist you. Training with others can help motivate you.
- N.B.** This list should not be taken as exhaustive

## CARE & MAINTENANCE:

1. Use a warm,damp cloth to keep upholstery clean.
2. Check for full engagement of locking pins.
3. Check that any of the adjustment devices are not projecting.

**Maximum weight limit including  
bodyweight 250 kg**

**Dimensions when built :**

**L = 215cm, W =70cm, H = 181cm.**

SHOULD YOU REQUIRE ASSISTANCE REGARDING WORN, MISSING OR DEFECTIVE PARTS PLEASE CONTACT OUR HELPLINE ON (01327) 701824.

WE WILL REQUIRE THE BATCH NUMBER (LOCATED ON A STICKER, ON THE BACK OF THE UPHOLSTERY).

IF THE PARTS YOU ARE MISSING FROM THE BAG THEN WE WILL ALSO REQUIRE THE INFORMATION PRINTED ON THE BAG.

1

Nuts should not be fully tightened.

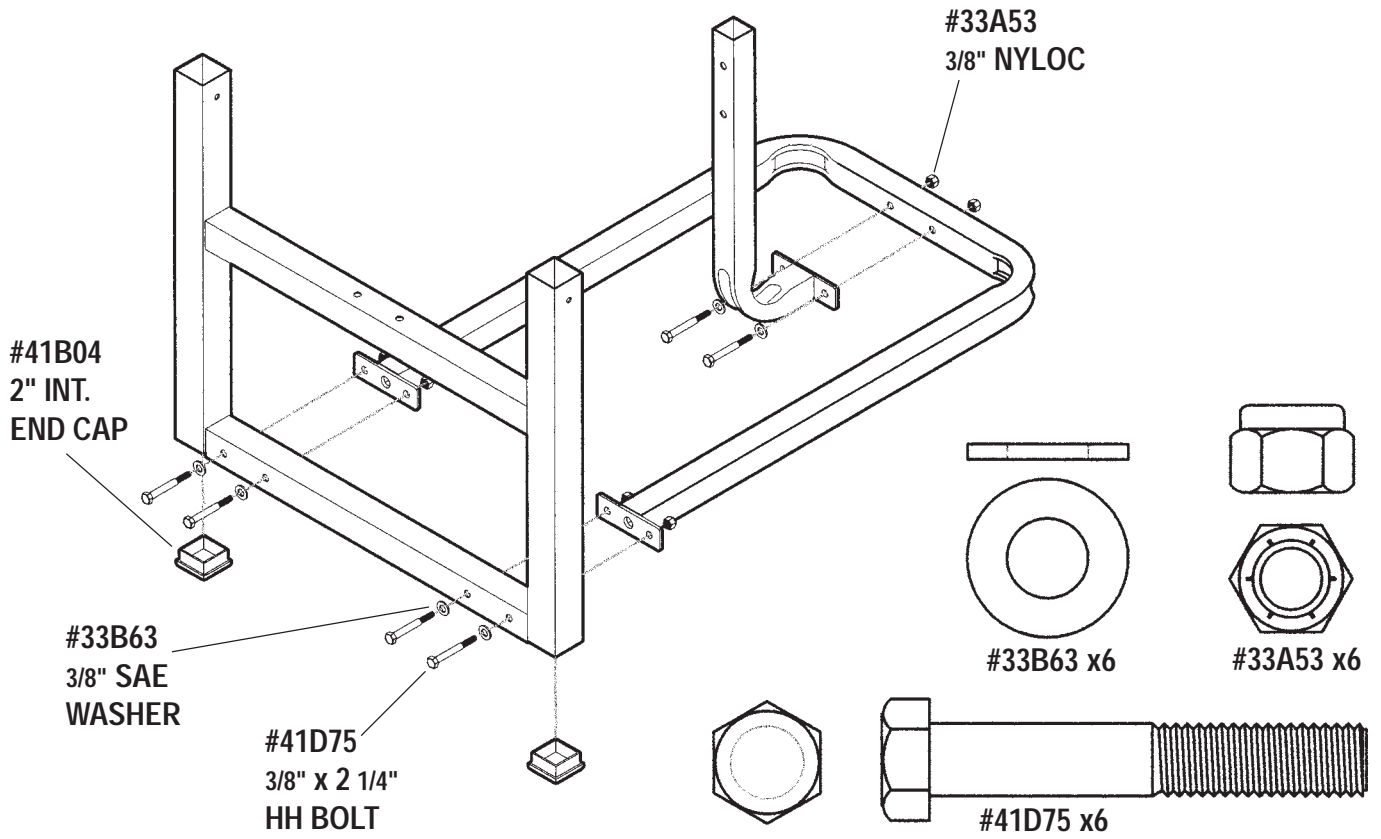

2

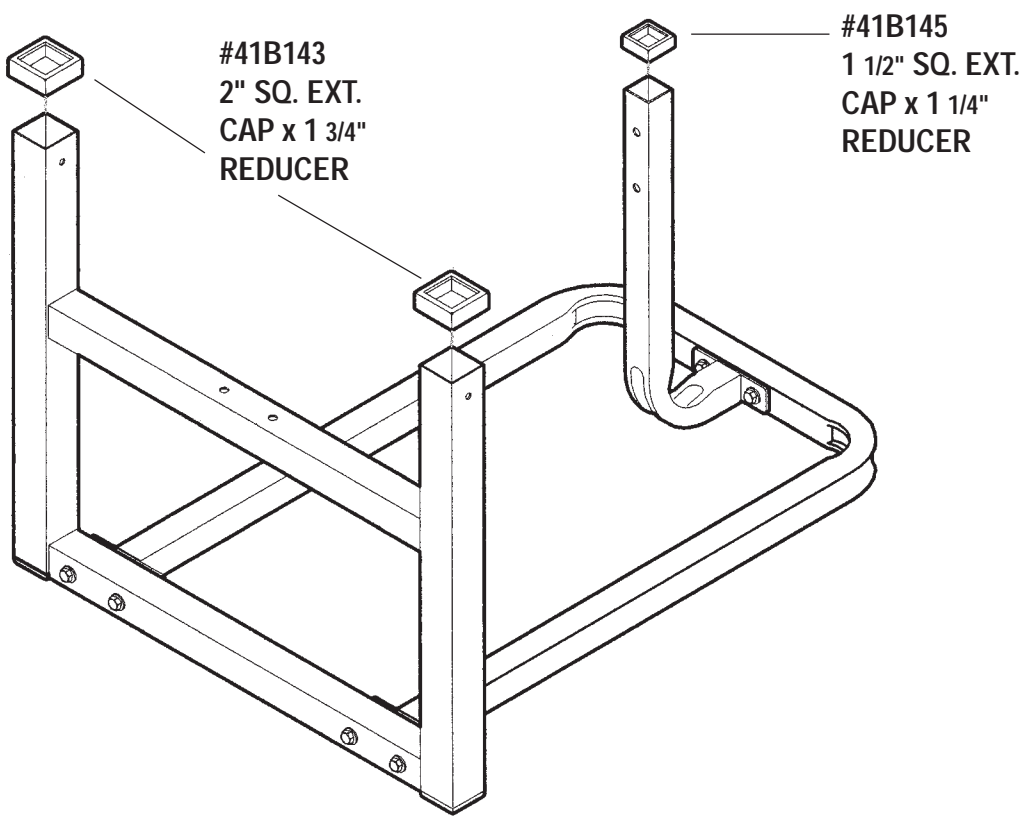

SHOULD YOU REQUIRE ANY ASSISTANCE REGARDING THIS PRODUCT PLEASE CONTACT YORK DIRECTLY.

3

#41D75  
3/8 x 2 1/4"  
HH BOLT

#33B63  
3/8" SAE  
WASHER

#33A53  
3/8" NYLOC

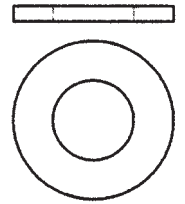
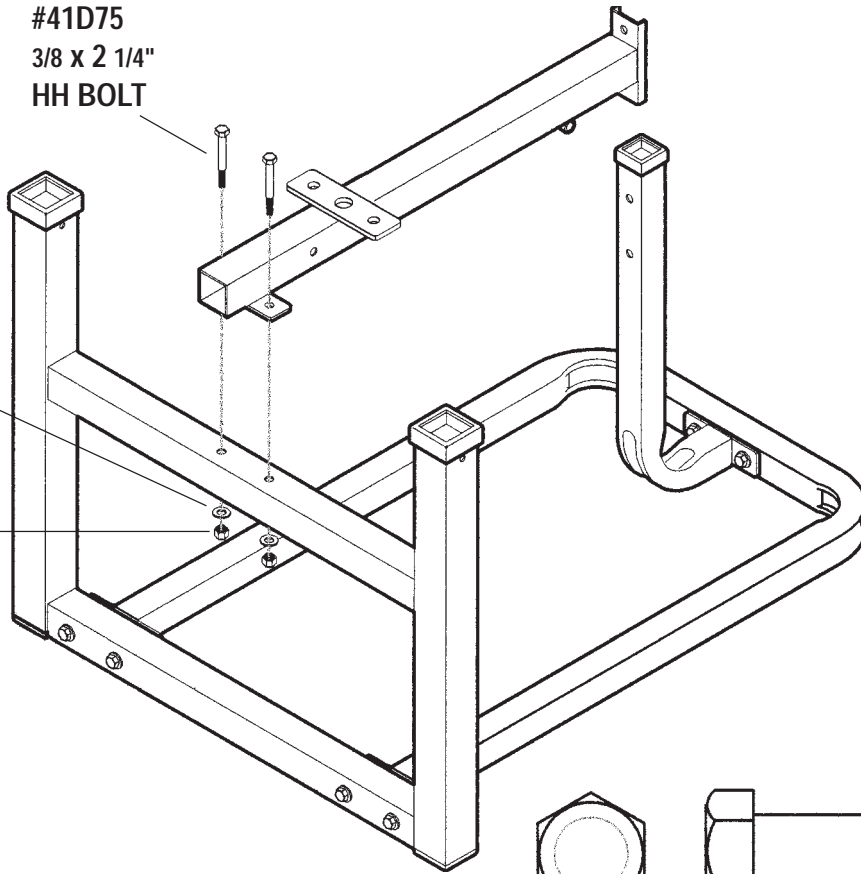

#33B63 x2



#33A53 x2

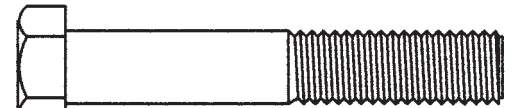

#41D75 x2

4

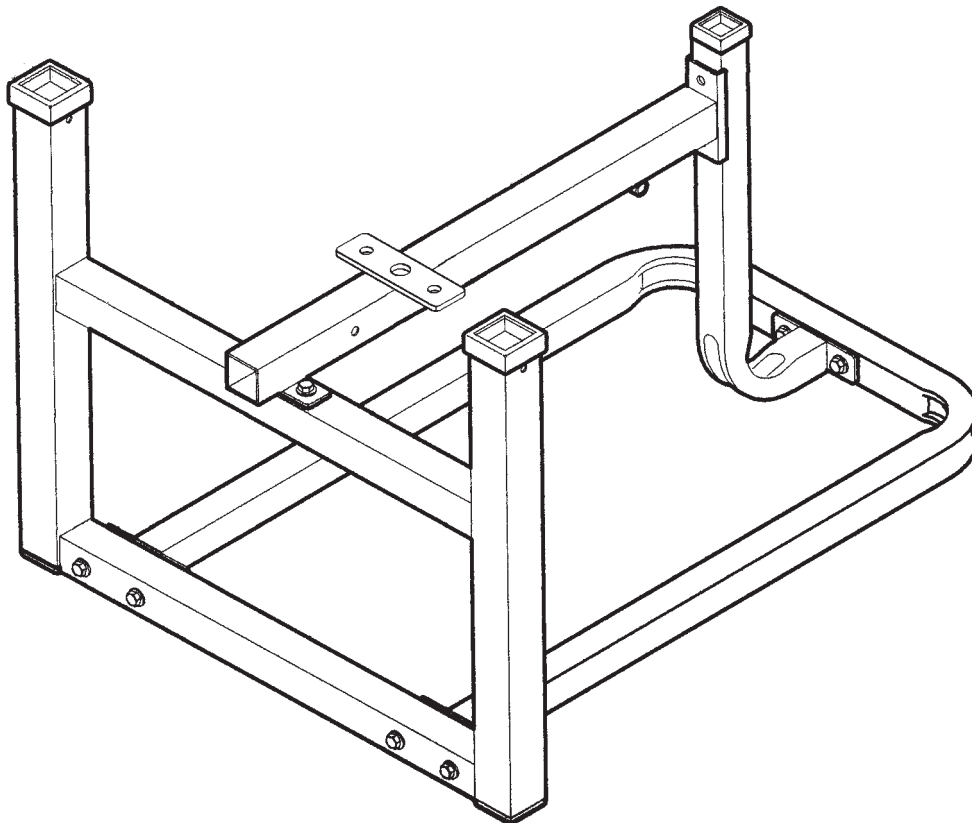

SHOULD YOU REQUIRE ANY ASSISTANCE REGARDING THIS PRODUCT PLEASE CONTACT YORK DIRECTLY.

5

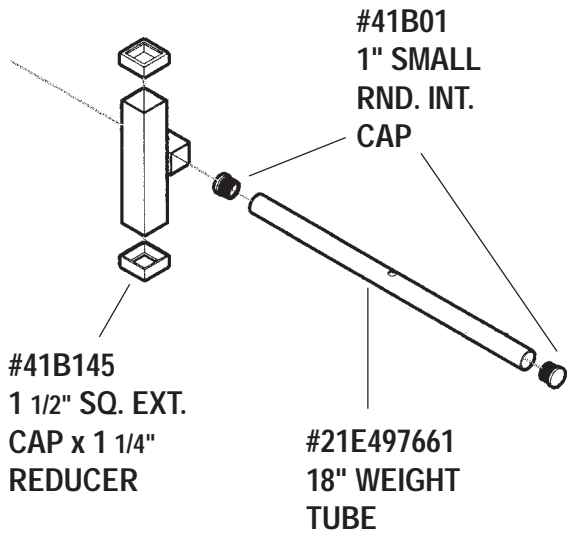

6

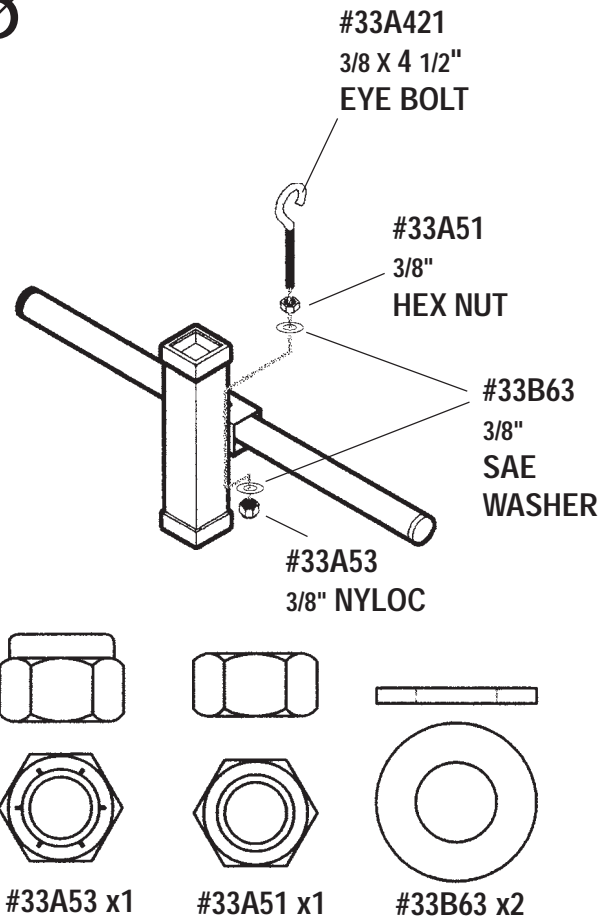

7

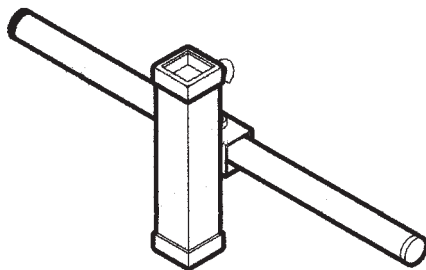

8

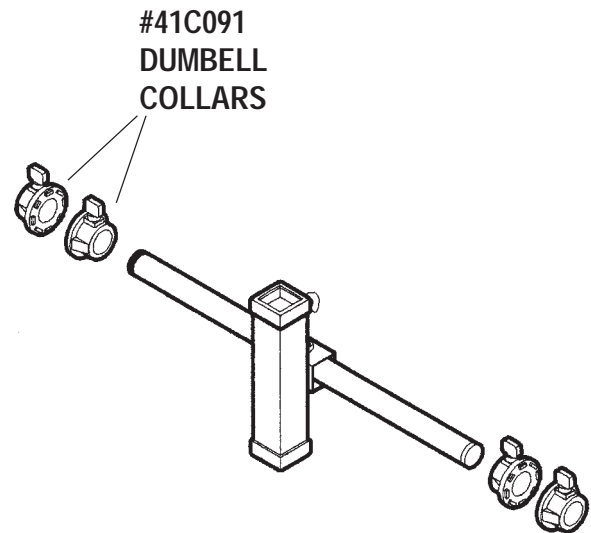

9

#41A82  
3" PULLEY  
WHEEL

#33A33  
5/16" NYLOC  
NUT

#33A53  
3/8" NYLOC

#33A45  
3/8" X 13/16"  
STRIPPER  
BOLT

#33A51  
3/8"  
HEX NUT

#33A421  
3/8 X 4 1/2"  
EYE BOLT

#33B63  
3/8"  
SAE  
WASHER

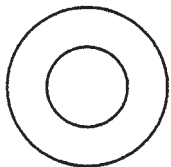

#33B63 x2



#33A33 x1



#33A51 x1

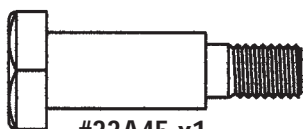

#33A45 x1



#33A53 x1

10

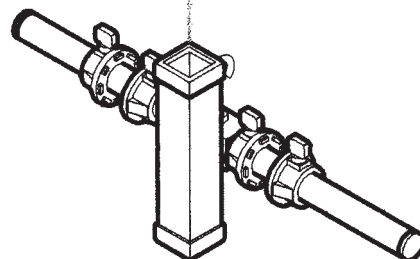
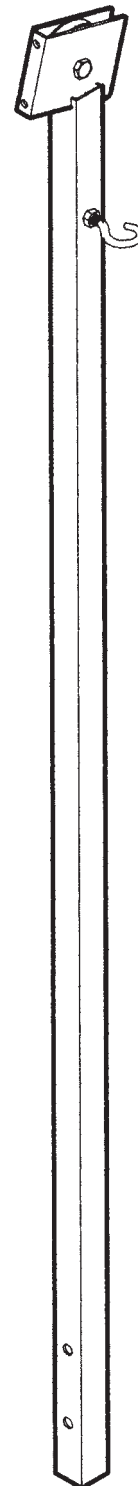

SHOULD YOU REQUIRE ANY ASSISTANCE REGARDING THIS PRODUCT PLEASE CONTACT YORK DIRECTLY.

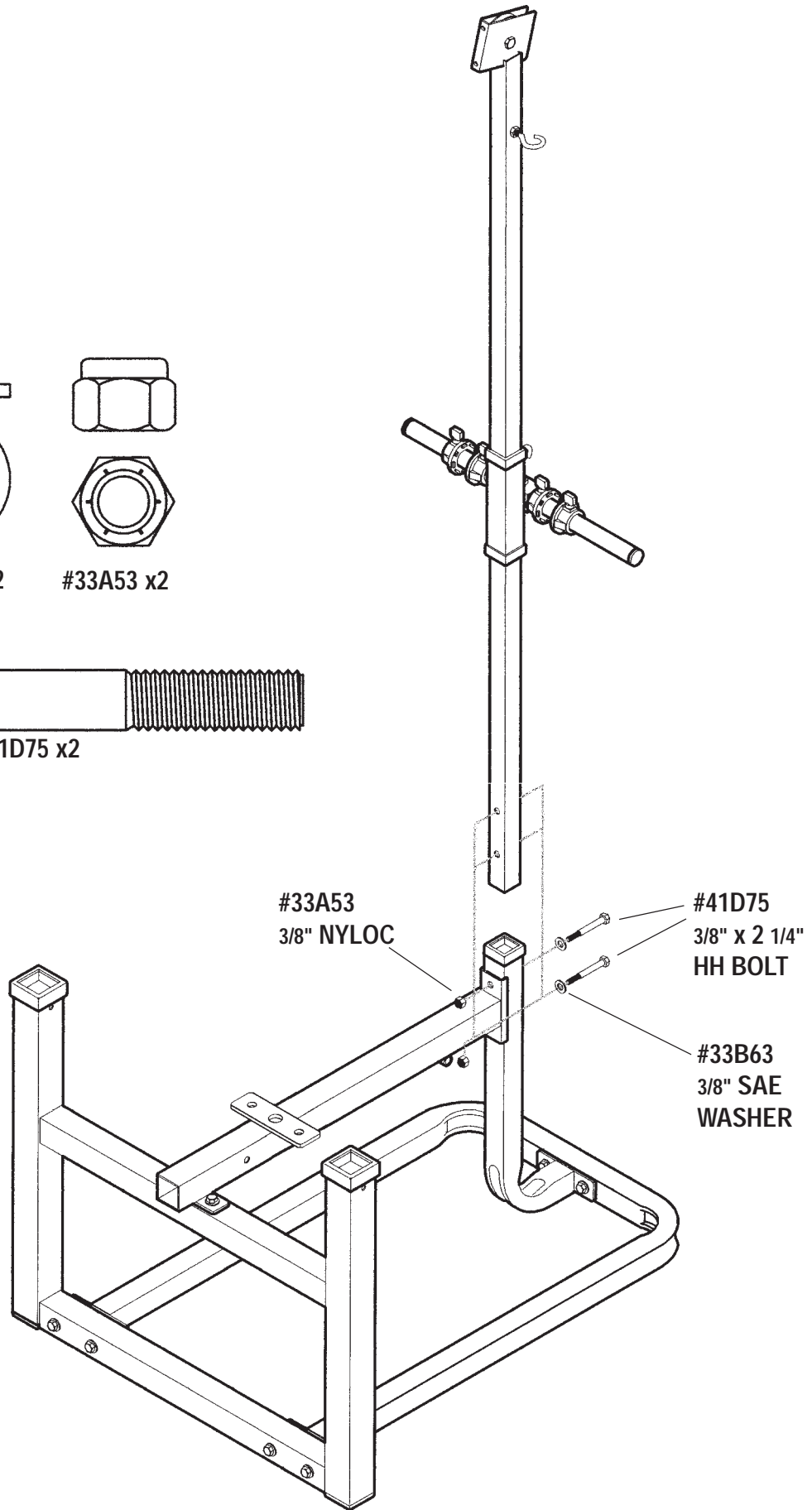
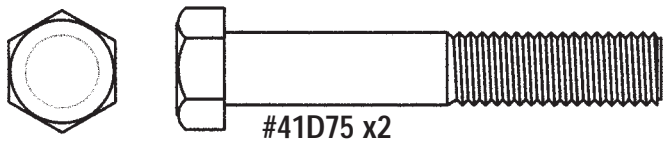
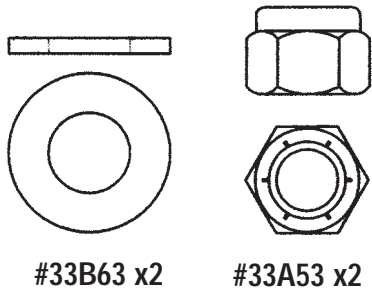

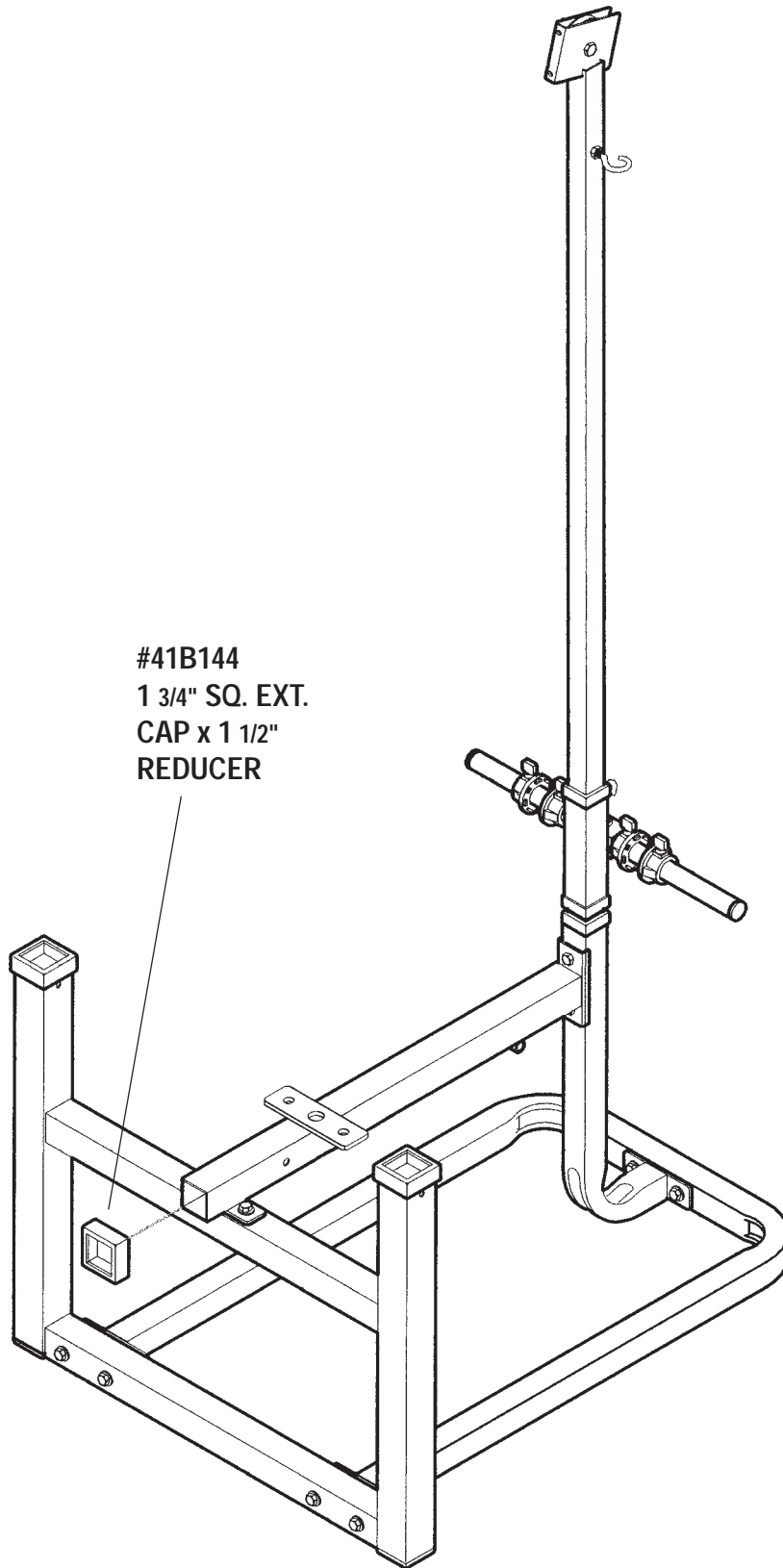

#41B144  
1 3/4" SQ. EXT.  
CAP x 1 1/2"  
REDUCER

13

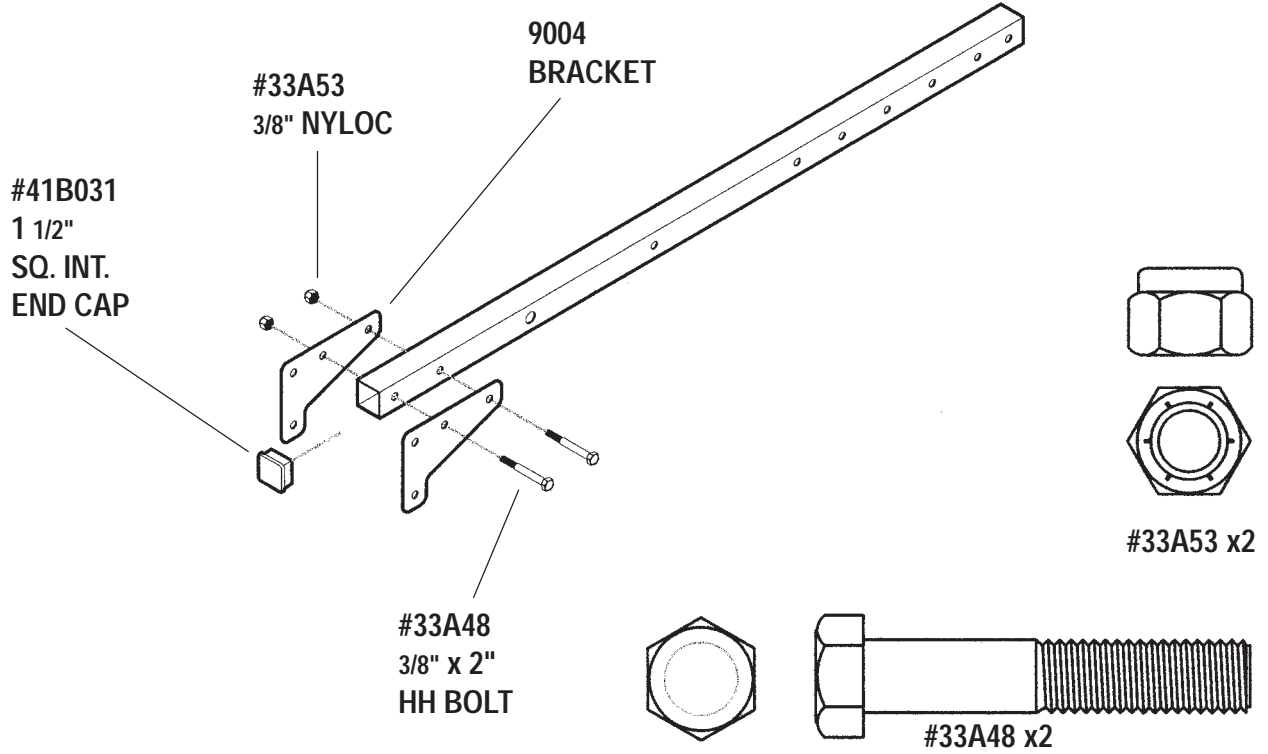

14

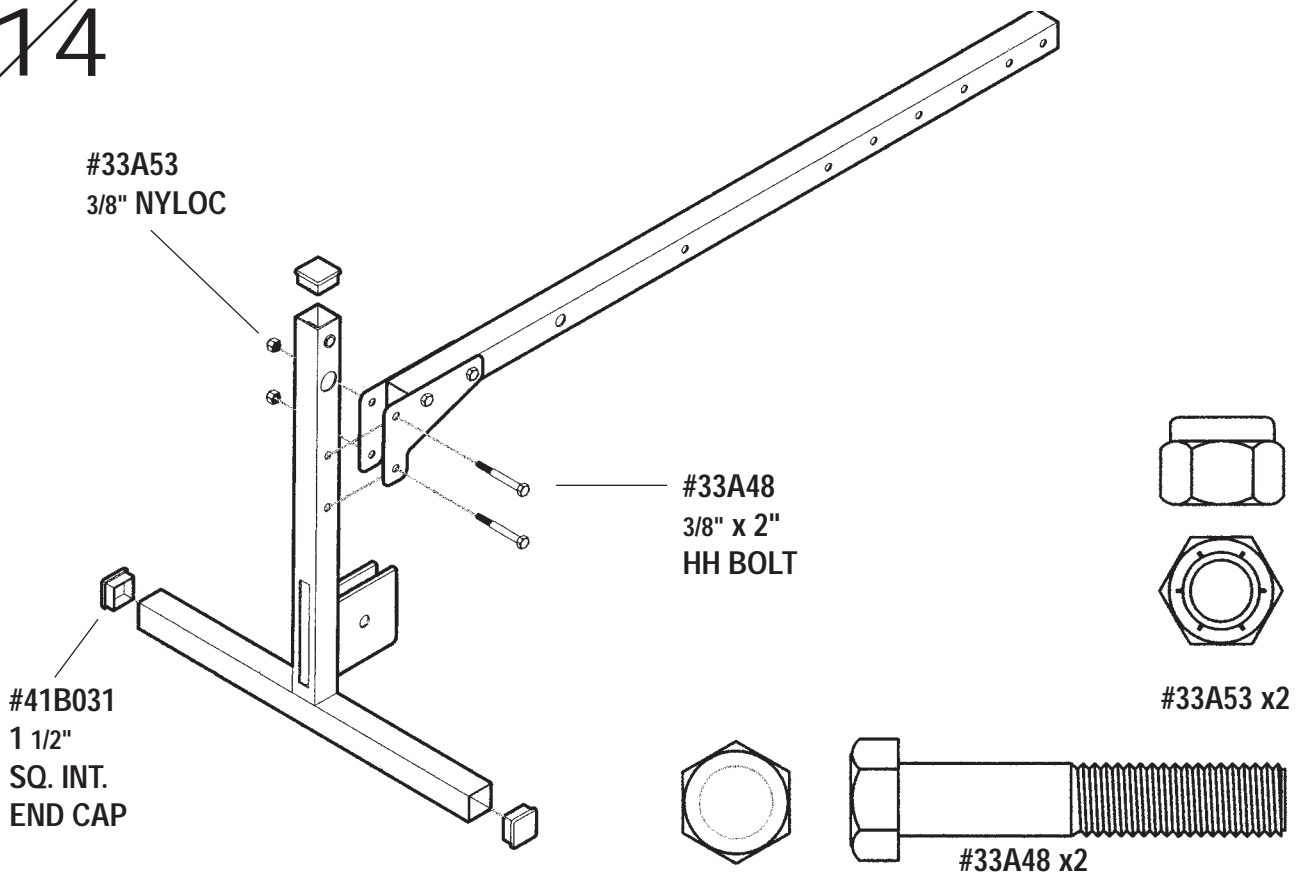

SHOULD YOU REQUIRE ANY ASSISTANCE REGARDING THIS PRODUCT PLEASE CONTACT YORK DIRECTLY.

15

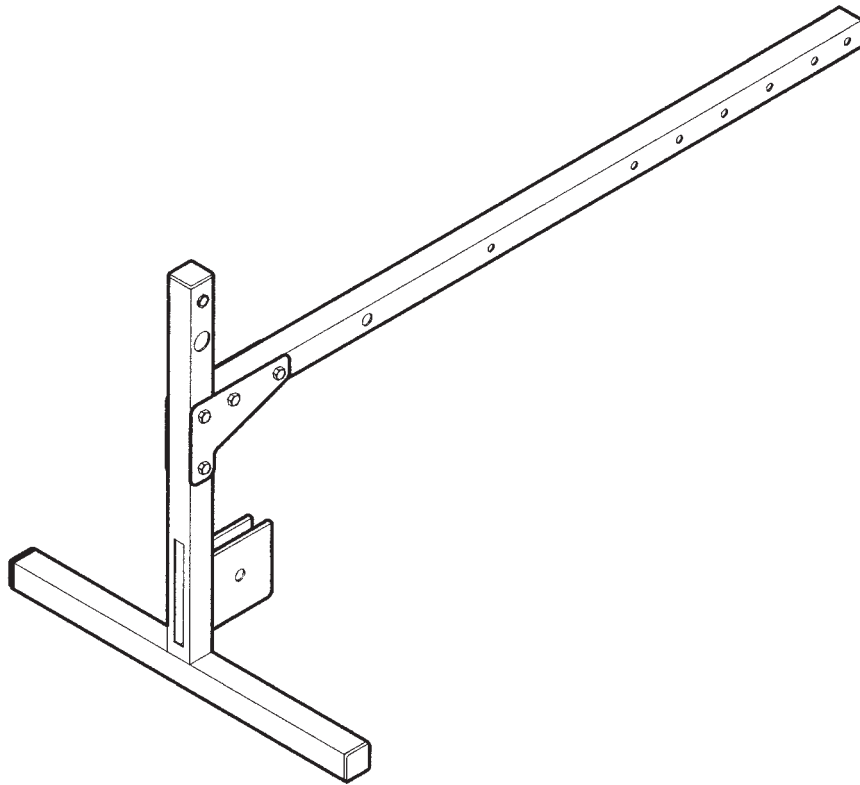

16

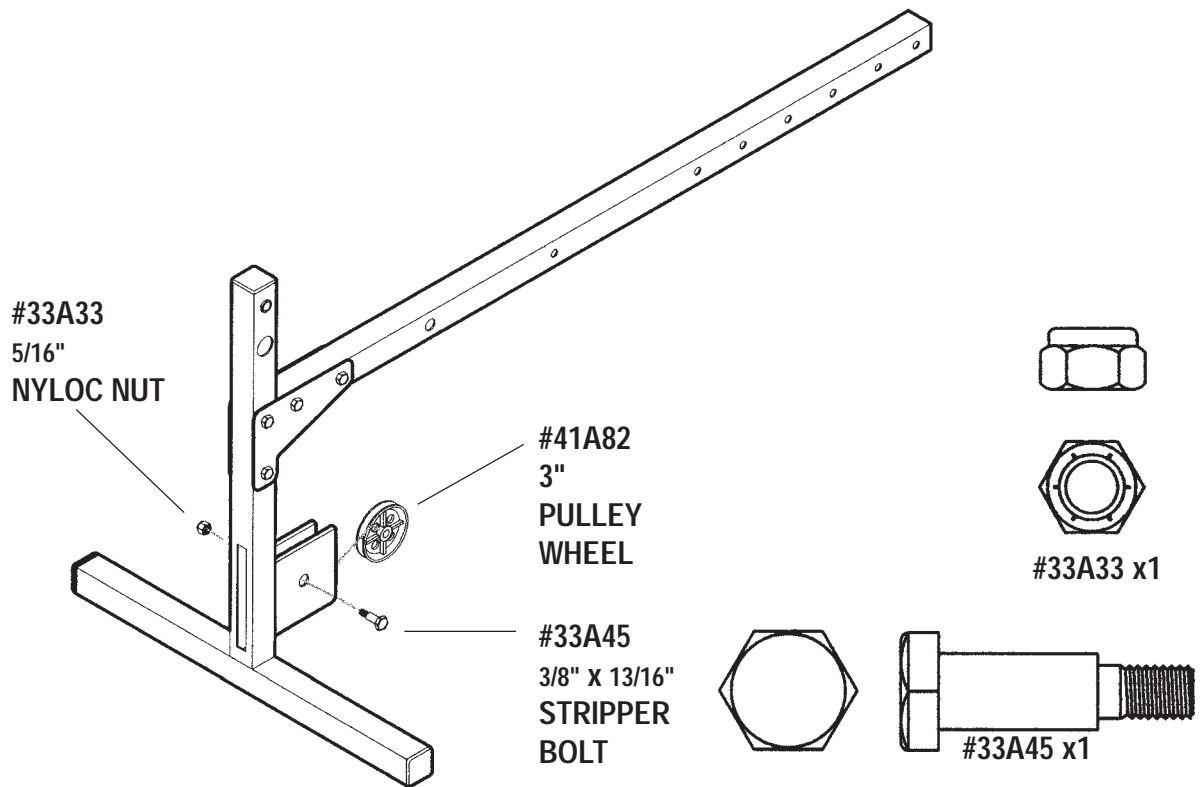

SHOULD YOU REQUIRE ANY ASSISTANCE REGARDING THIS PRODUCT PLEASE CONTACT YORK DIRECTLY.

17

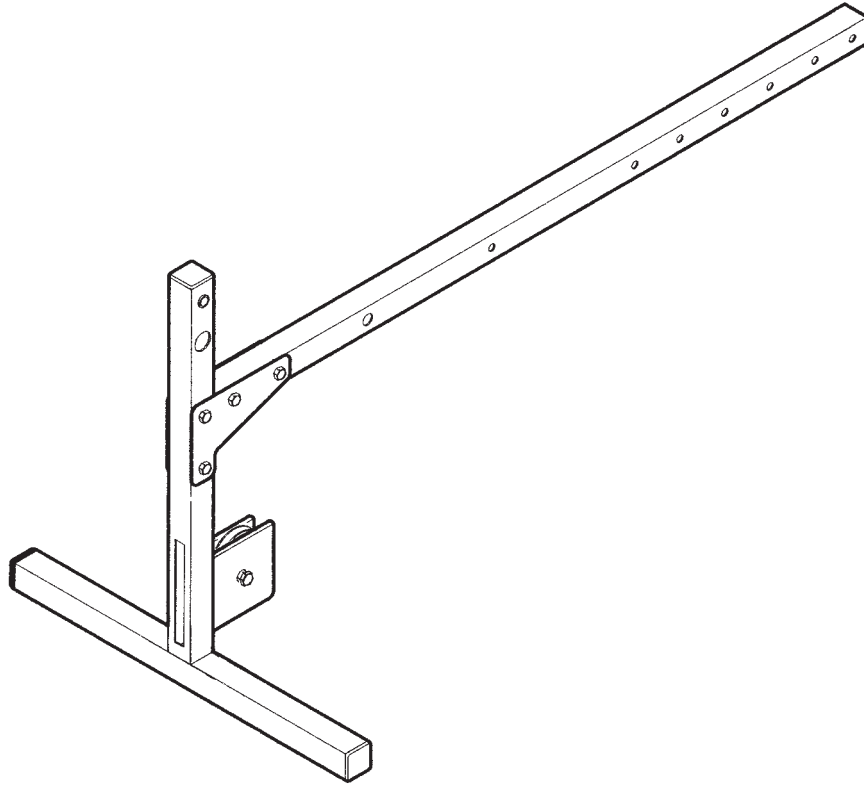

18

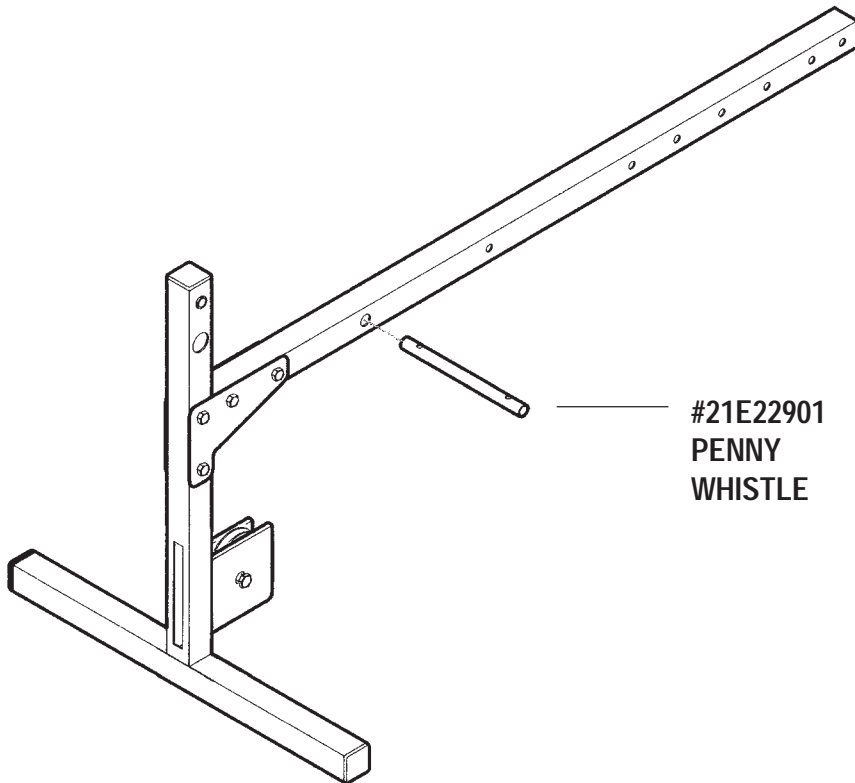

#21E22901  
PENNY  
WHISTLE

19

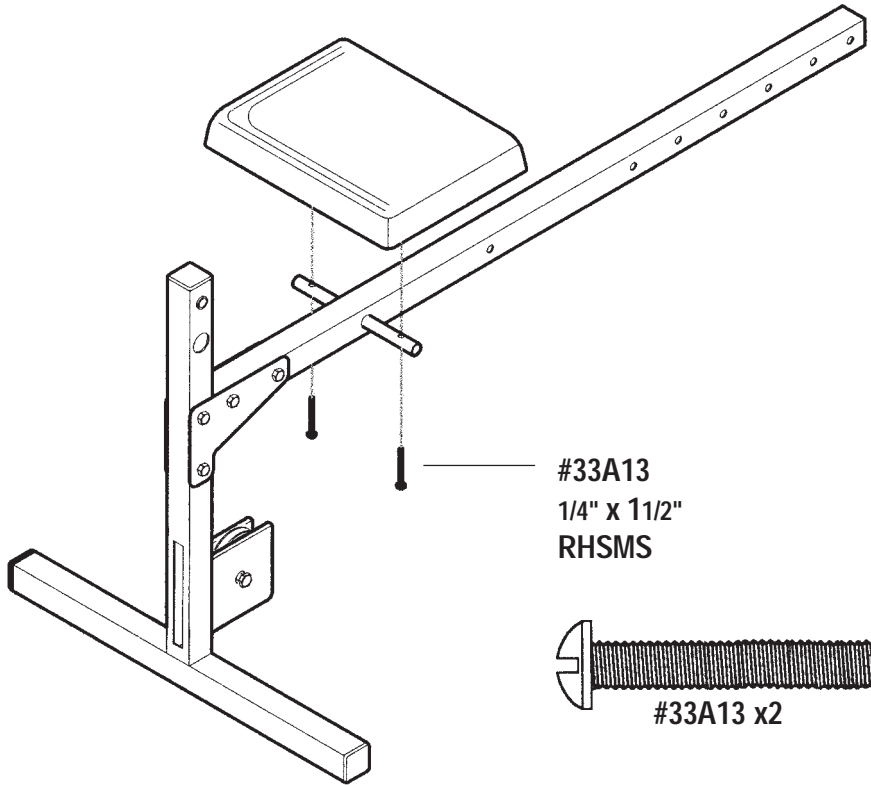

20

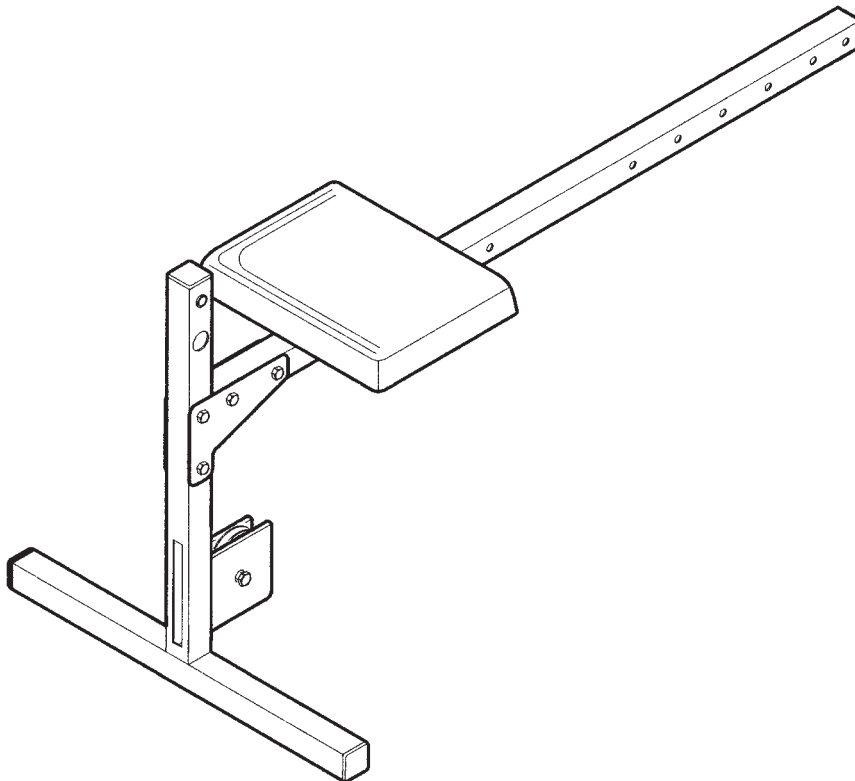

21

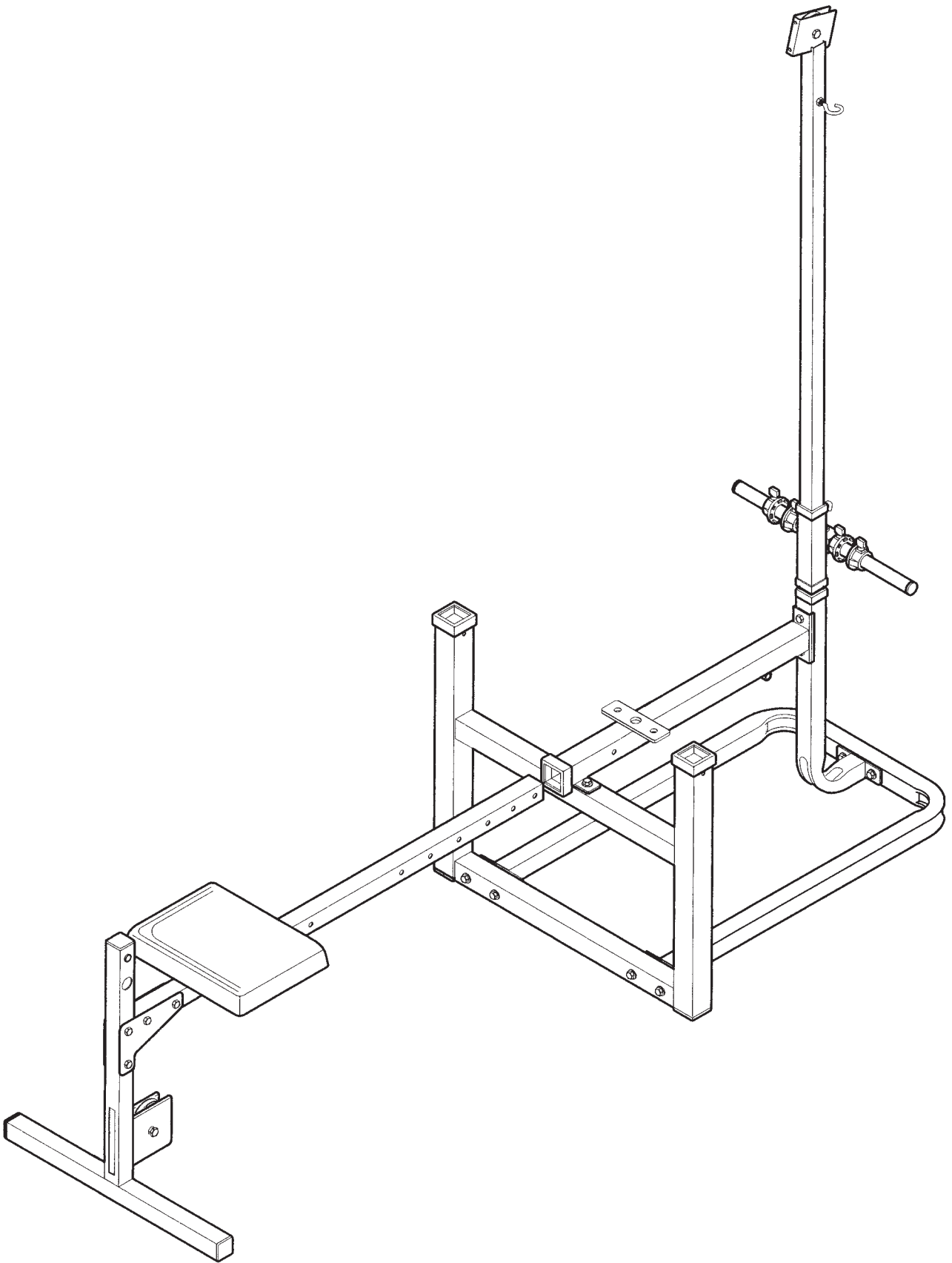

SHOULD YOU REQUIRE ANY ASSISTANCE REGARDING THIS PRODUCT PLEASE CONTACT YORK DIRECTLY.

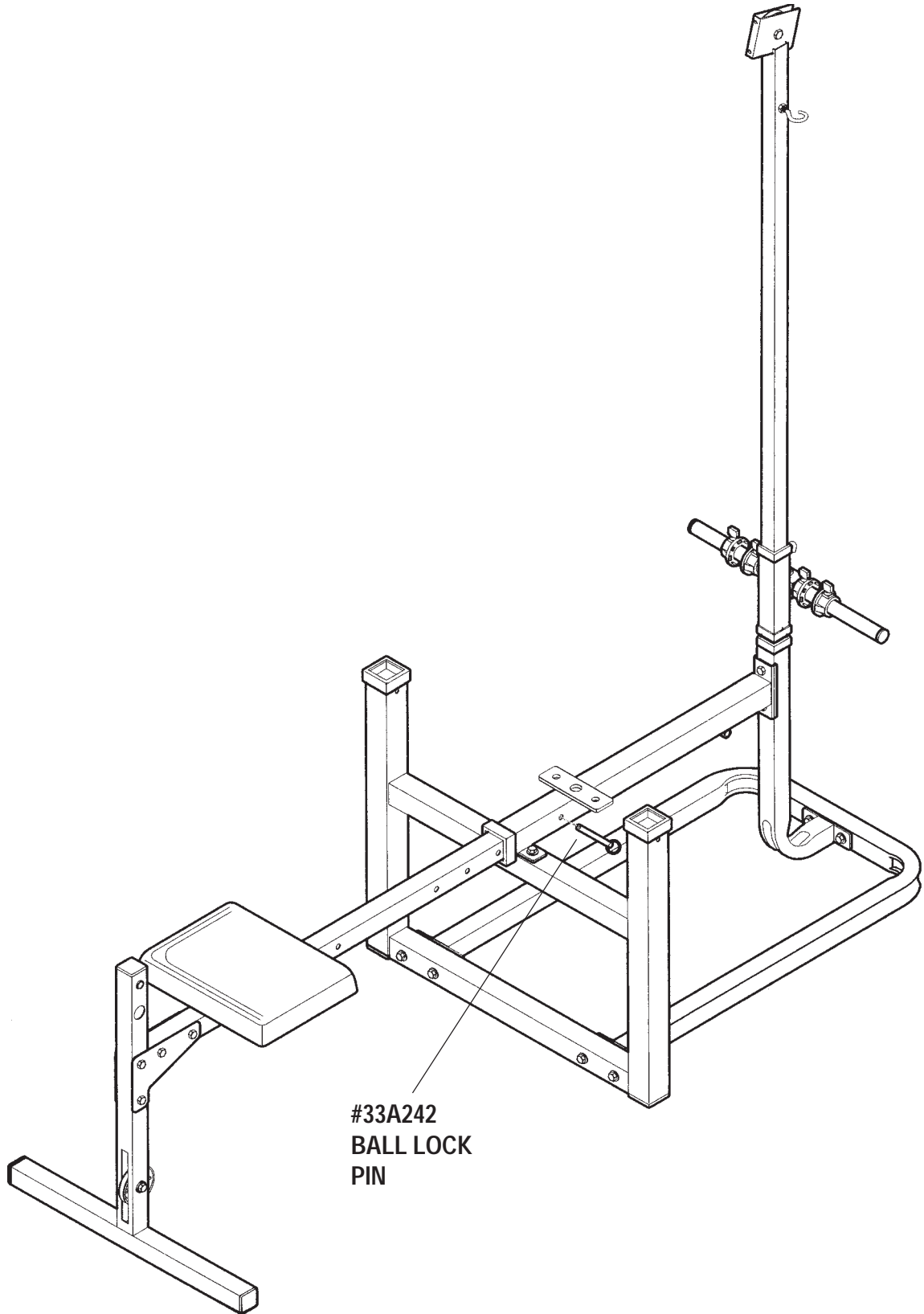

#33A242  
BALL LOCK  
PIN

23

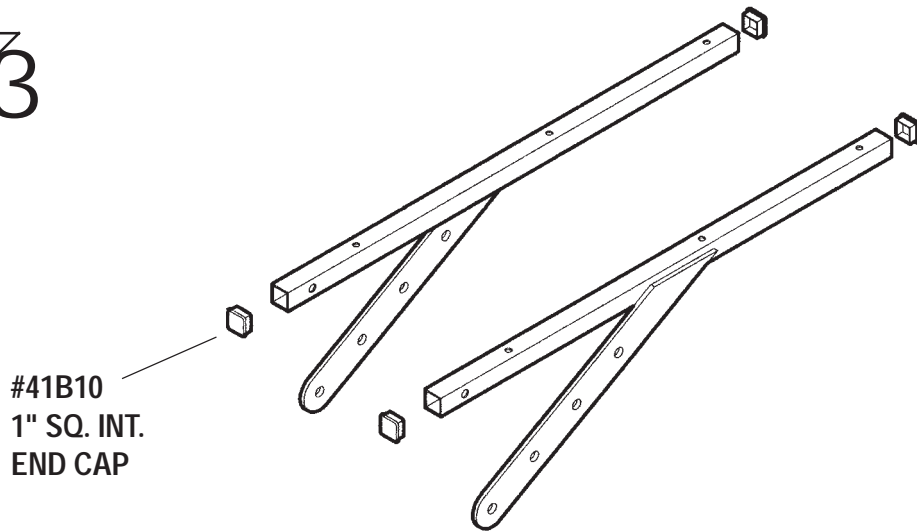

24

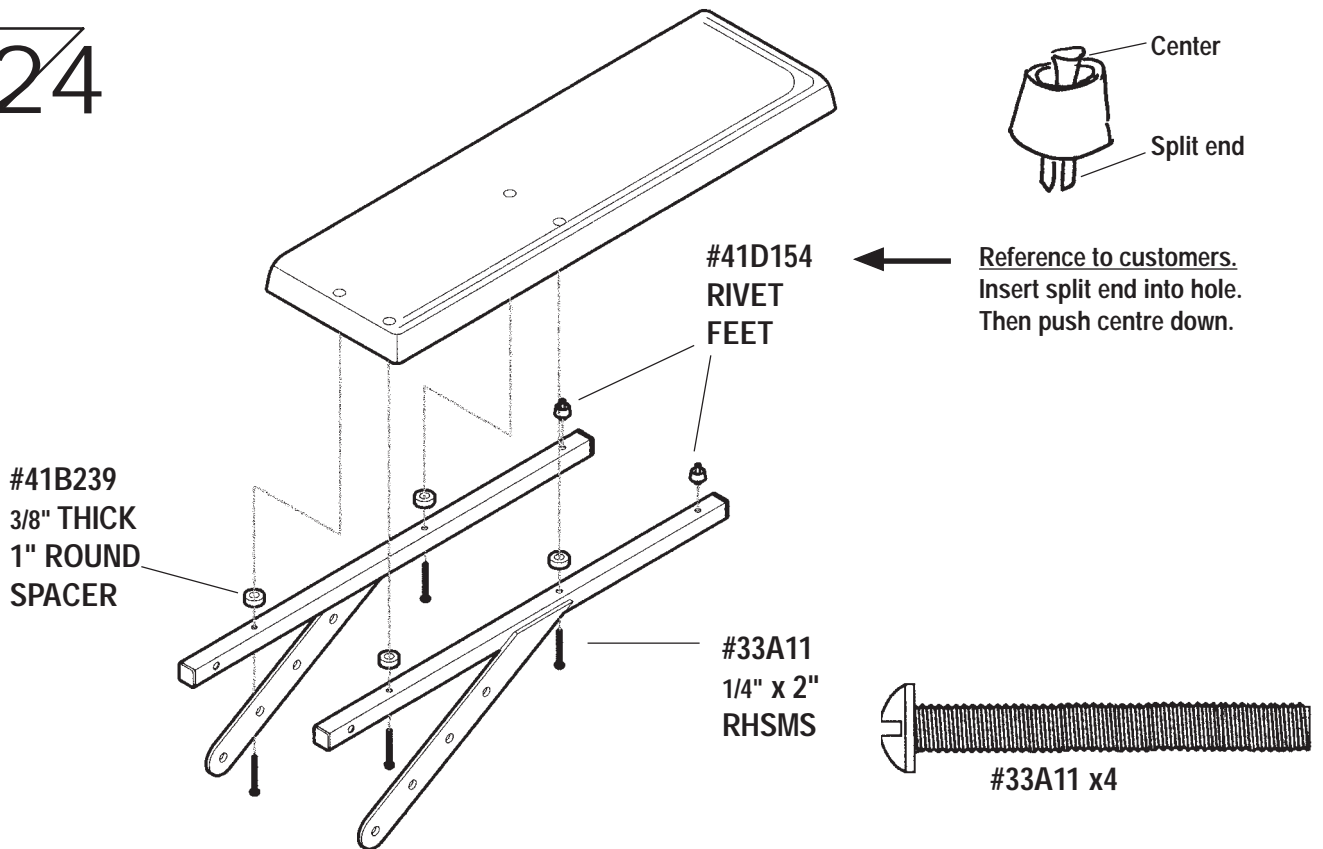

25

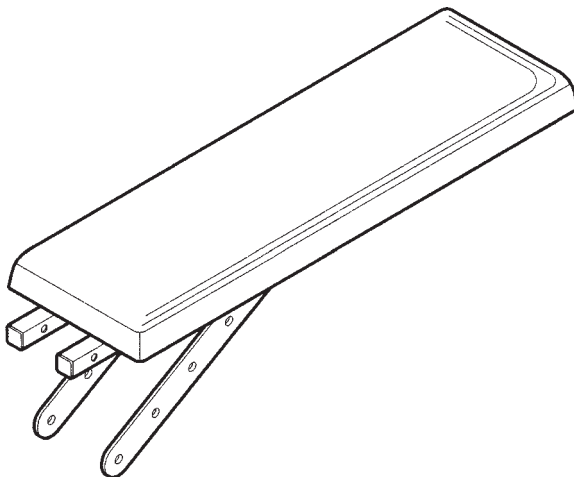

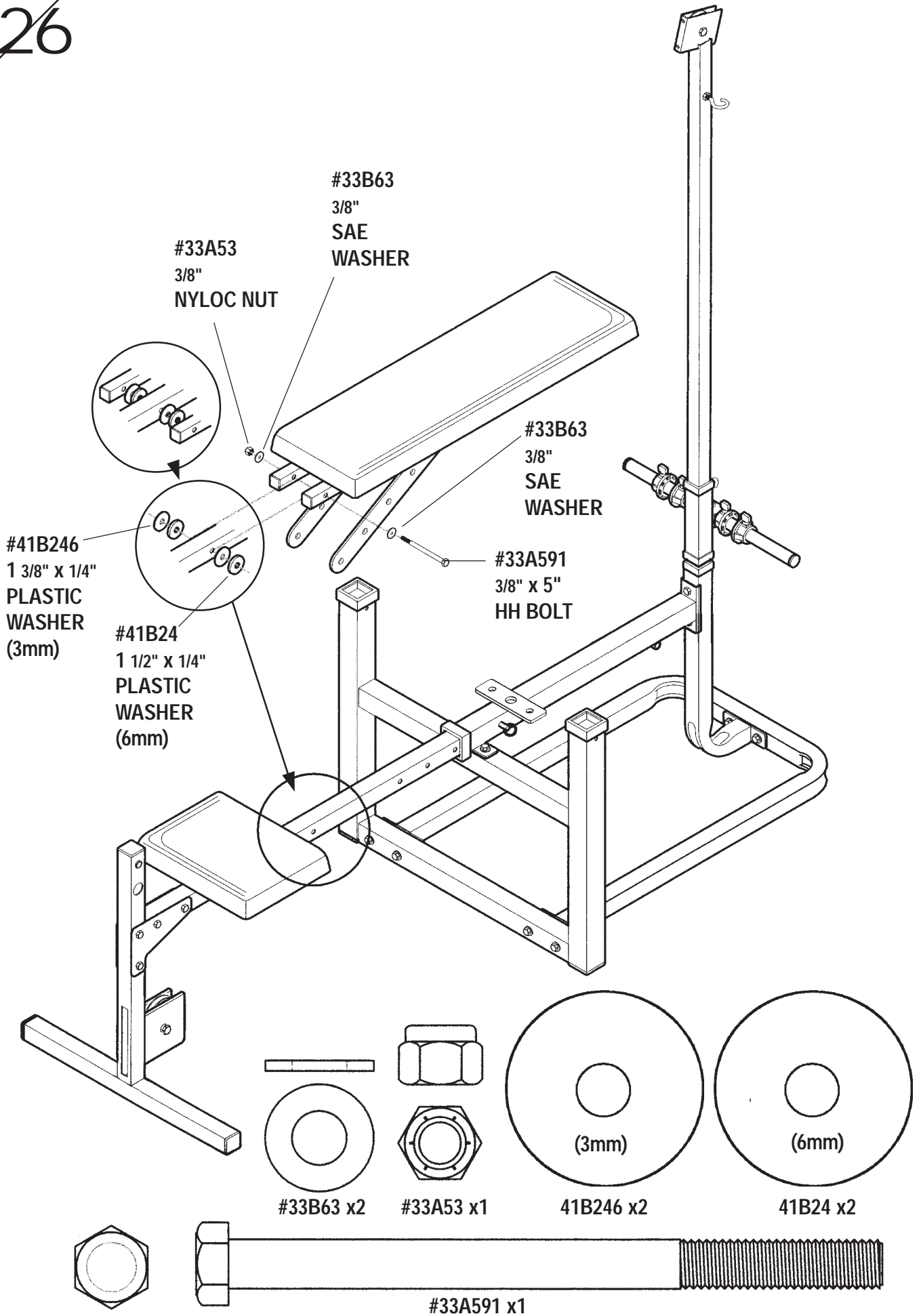

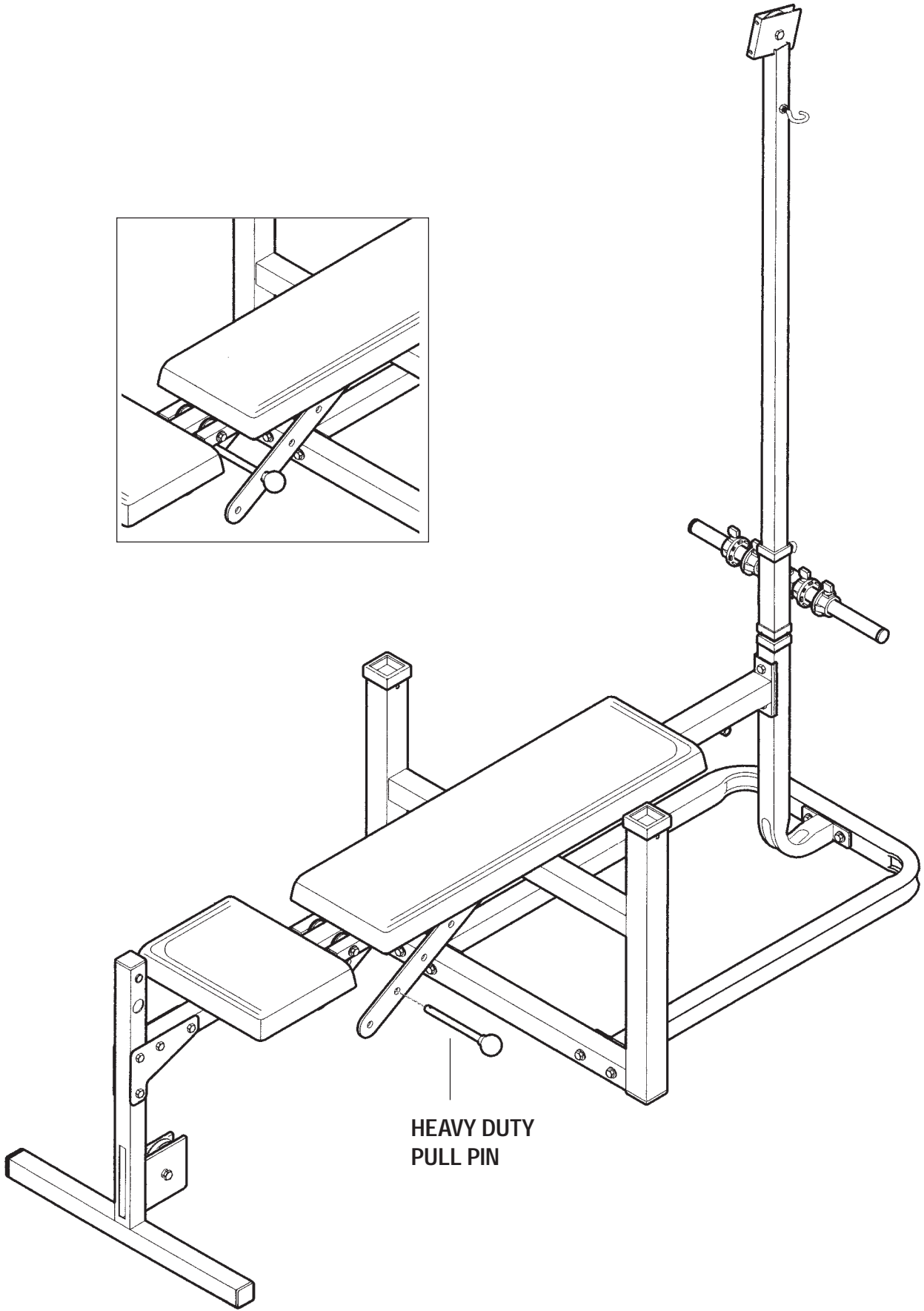
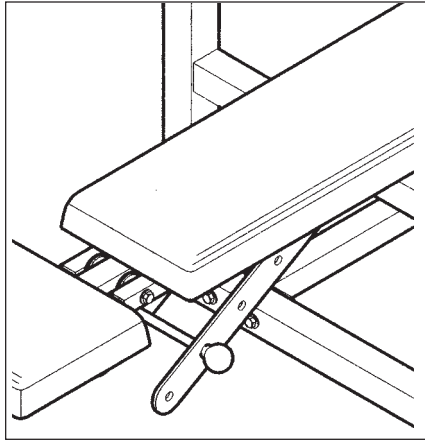

HEAVY DUTY  
PULL PIN

28

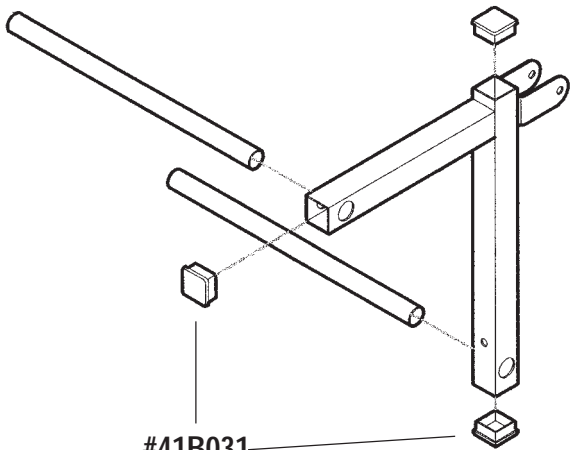

#41B031  
1 1/2"  
INT. END CAP

29

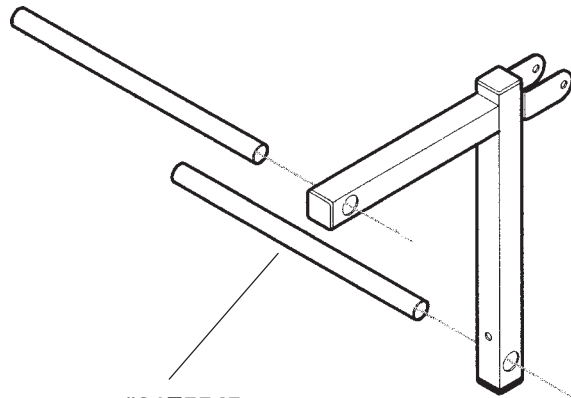

#21E5545  
16"  
TUBE

30

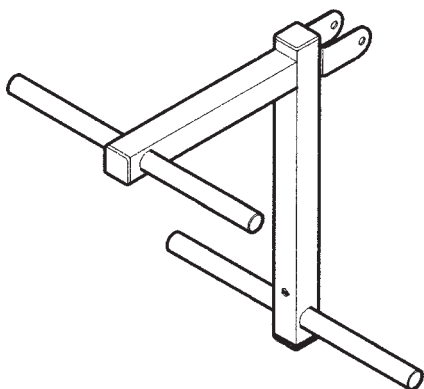

31

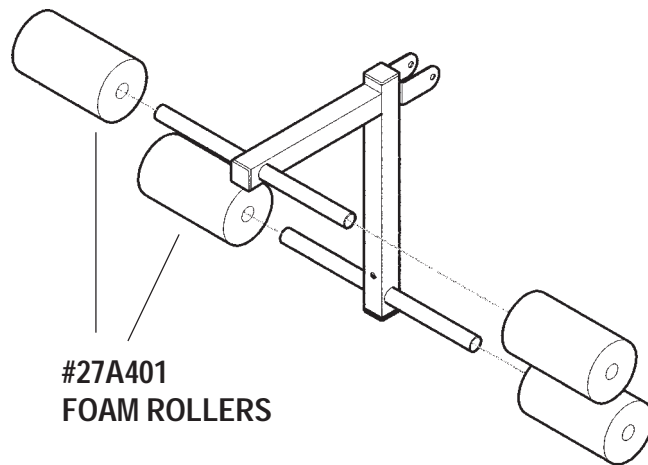

#27A401  
FOAM ROLLERS

32

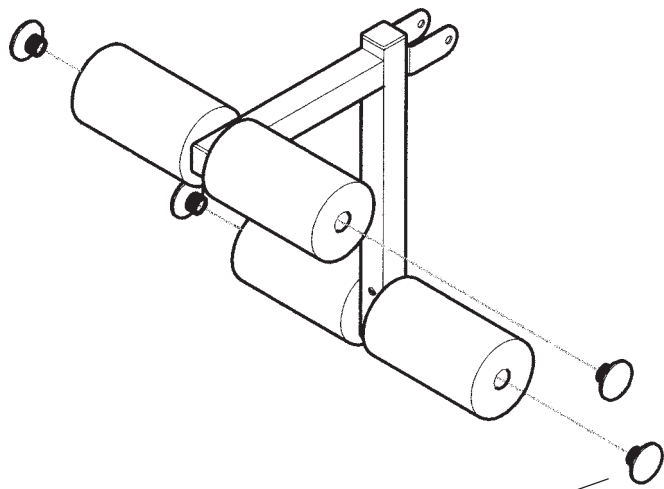

#41B21  
1"  
ROUND INT.  
FOAM CAPS

33

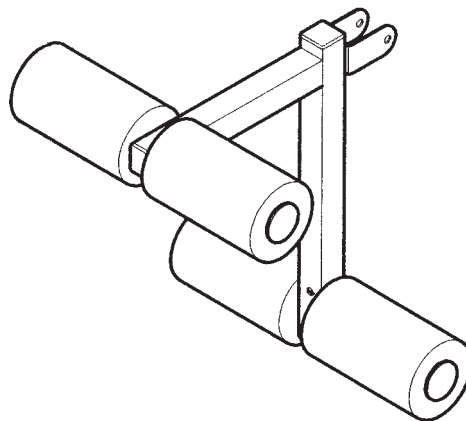

34

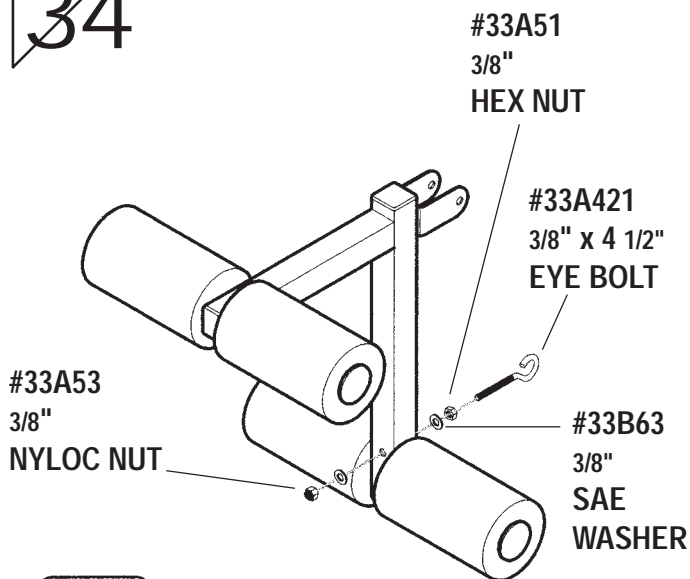

#33A51  
3/8"  
HEX NUT

#33A421  
3/8" x 4 1/2"  
EYE BOLT

#33A53  
3/8"  
NYLOC NUT

#33B63  
3/8"  
SAE  
WASHER



#33A53 x1

#33A51 x1

#33B63 x2

35

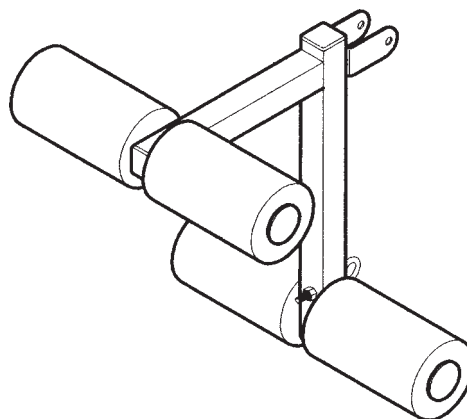

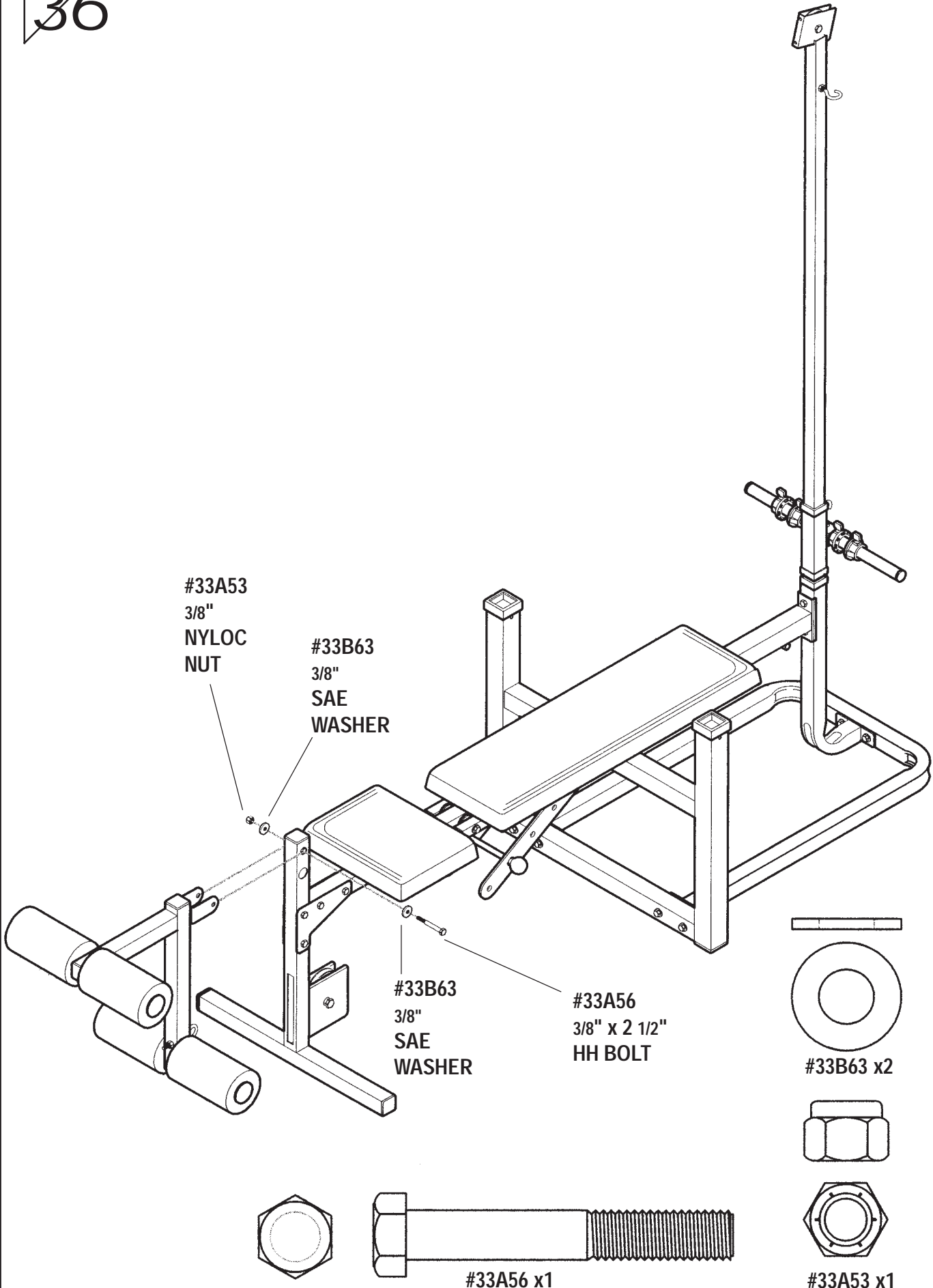

37

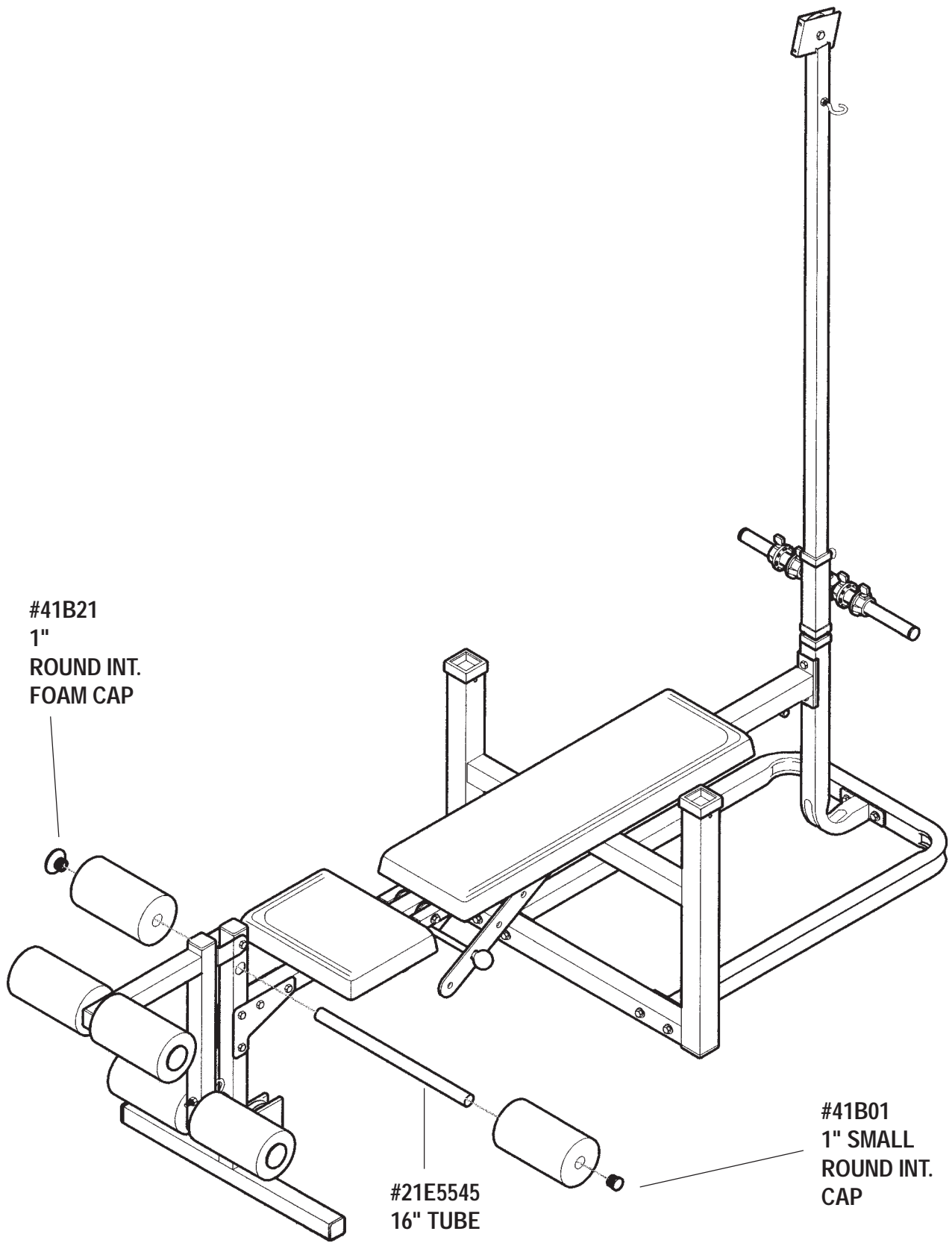

#41B21  
1"  
ROUND INT.  
FOAM CAP

#21E5545  
16" TUBE

#41B01  
1" SMALL  
ROUND INT.  
CAP

SHOULD YOU REQUIRE ANY ASSISTANCE REGARDING THIS PRODUCT PLEASE CONTACT YORK DIRECTLY.

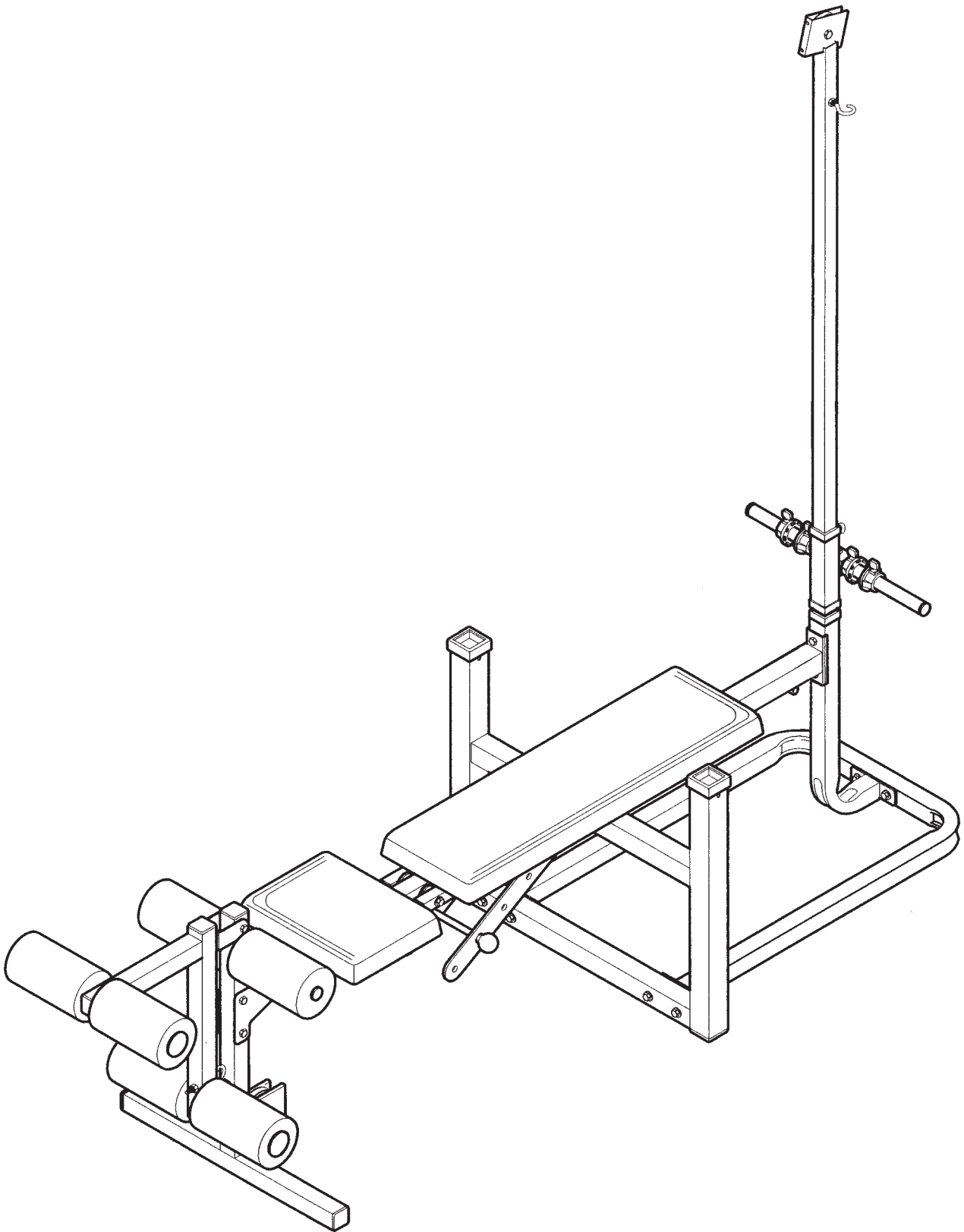

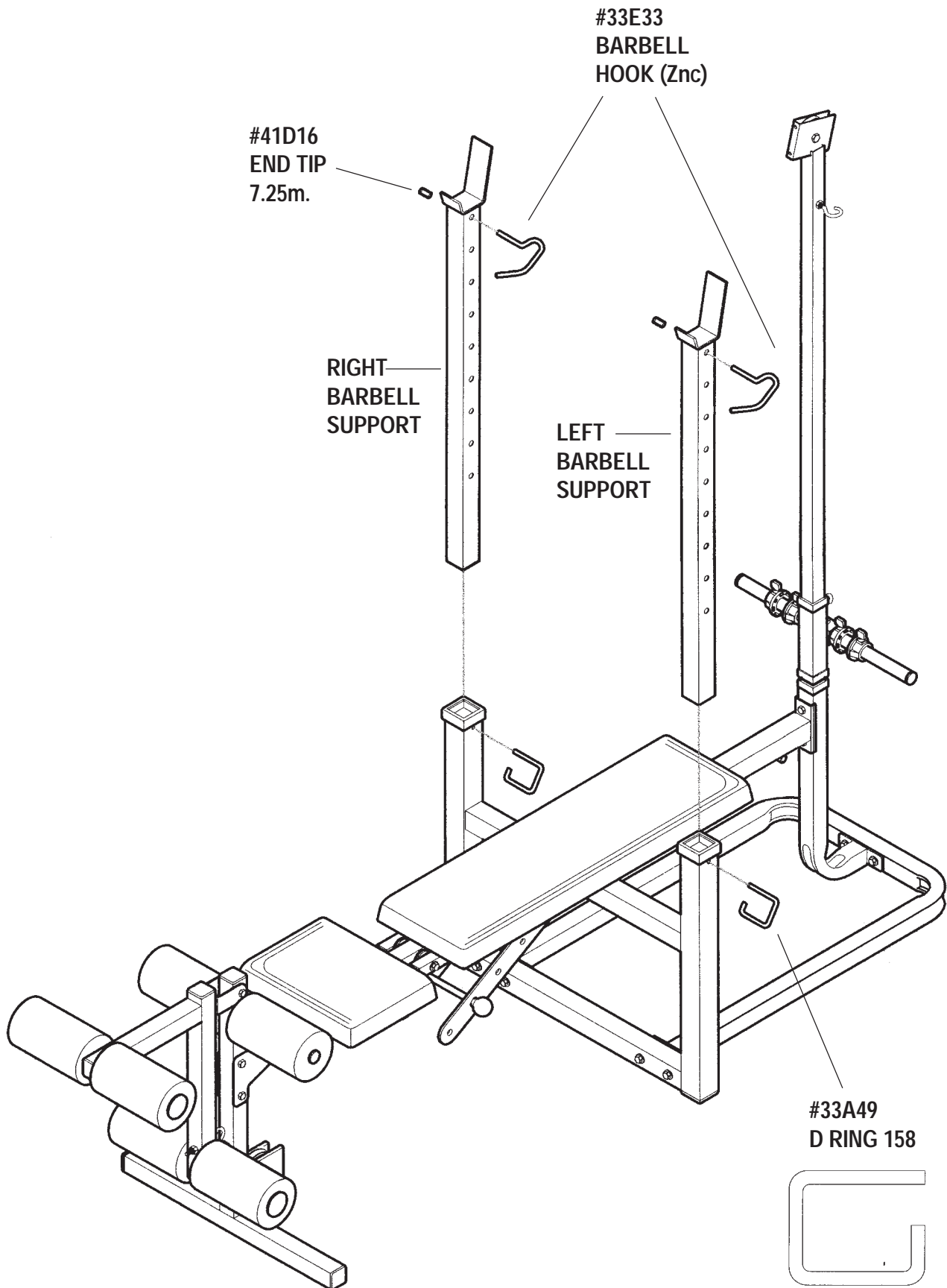

40

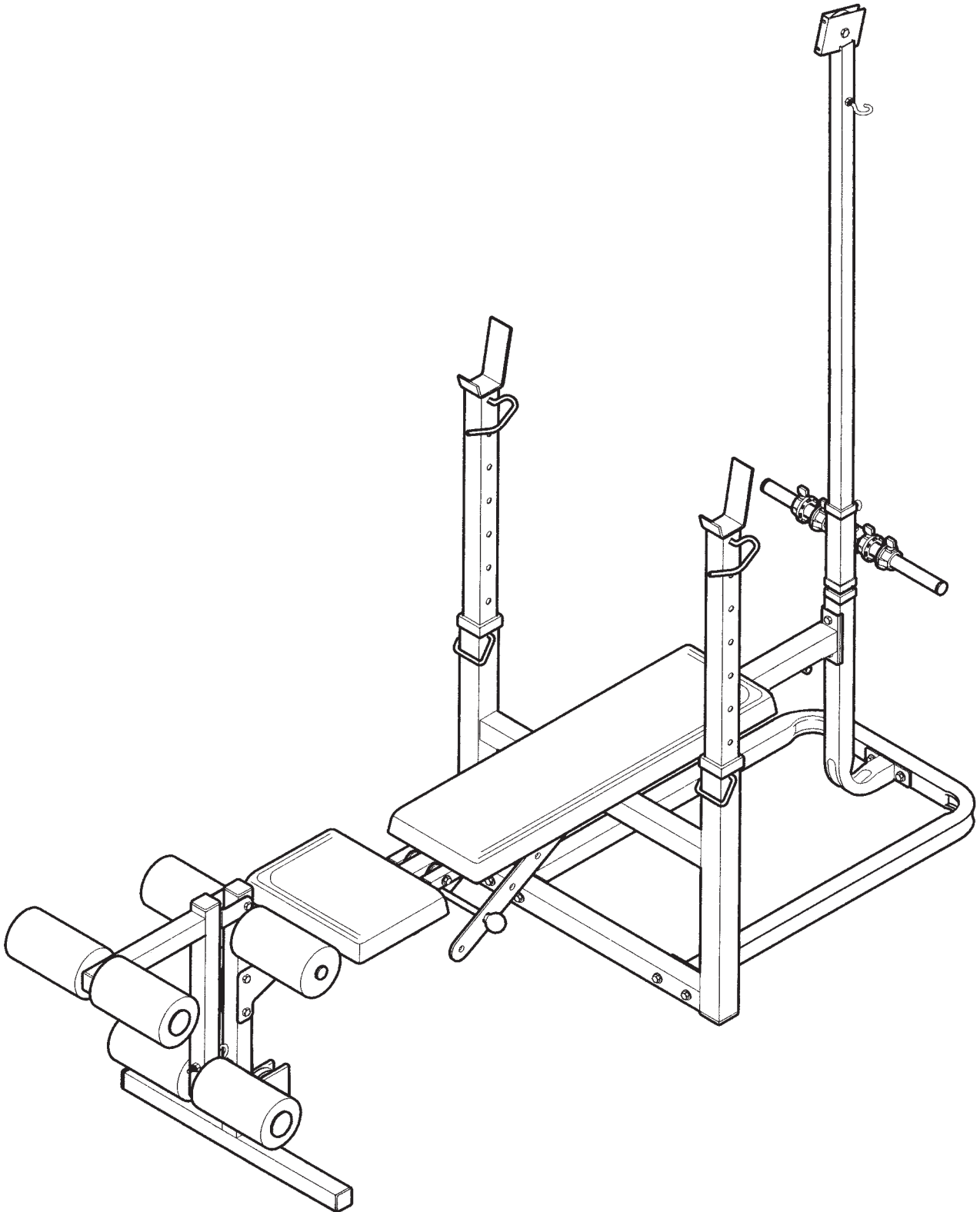

SHOULD YOU REQUIRE ANY ASSISTANCE REGARDING THIS PRODUCT PLEASE CONTACT YORK DIRECTLY.

41

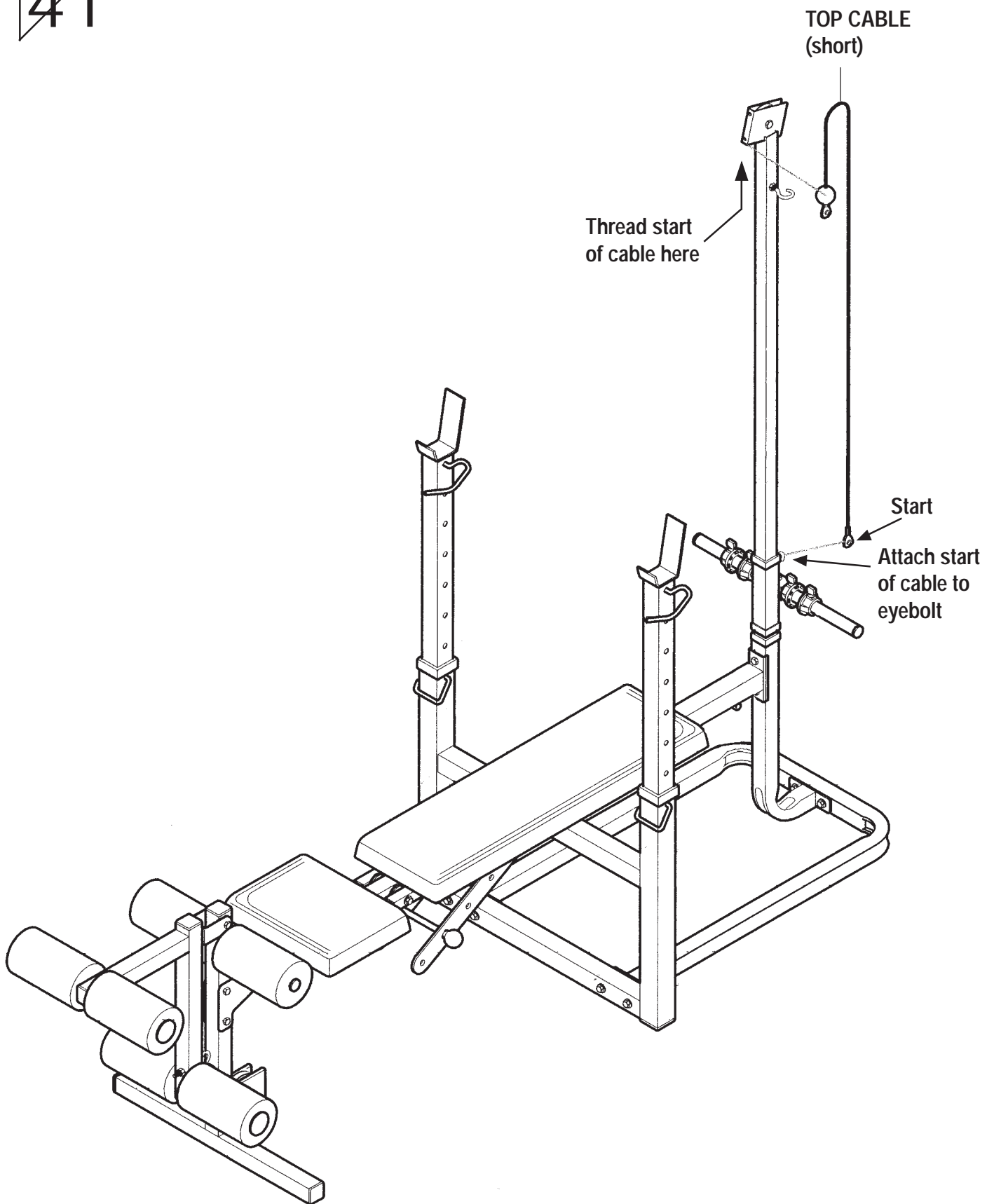

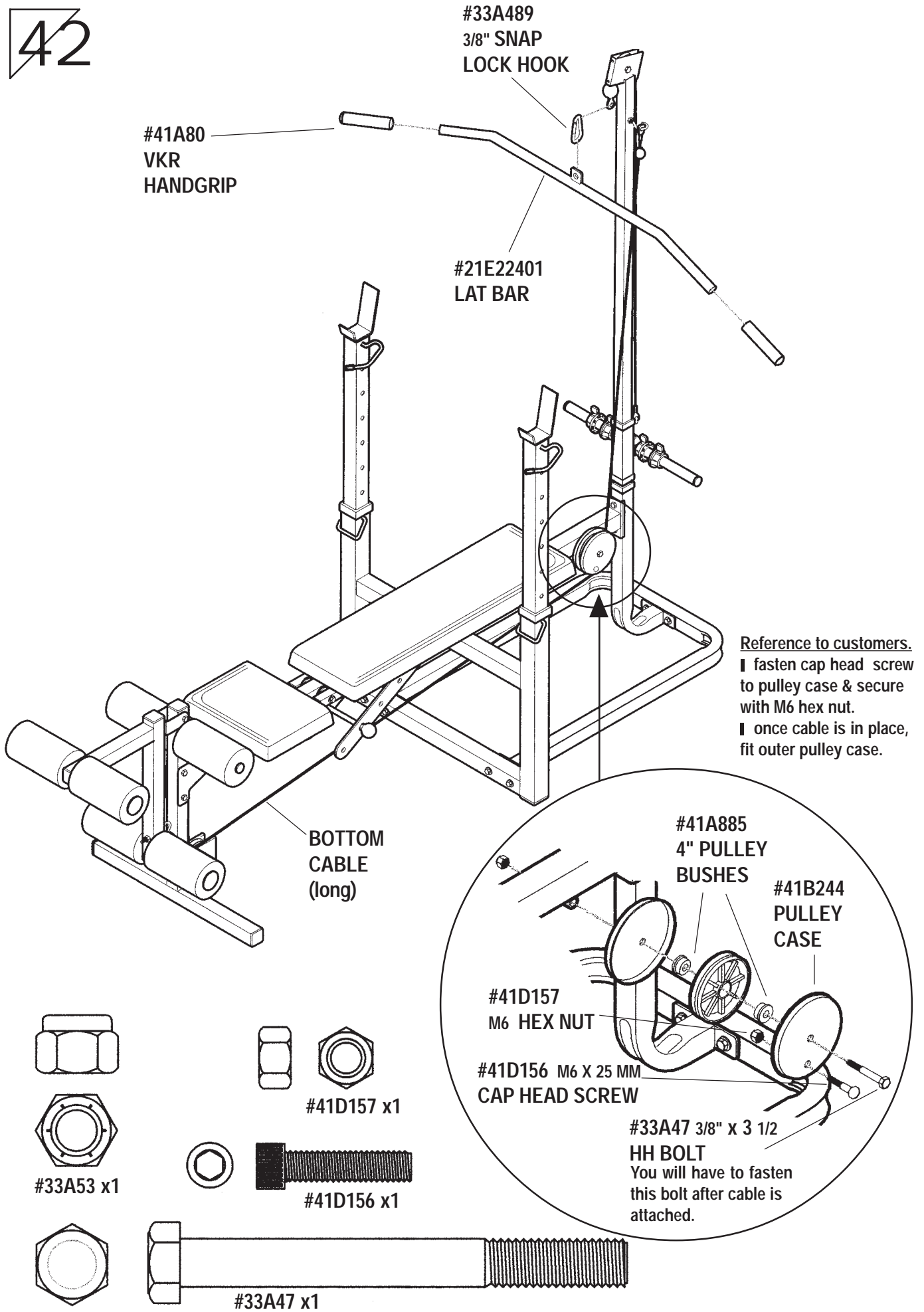

Reference to customers.  
 ■ fasten cap head screw to pulley case & secure with M6 hex nut.  
 ■ once cable is in place, fit outer pulley case.

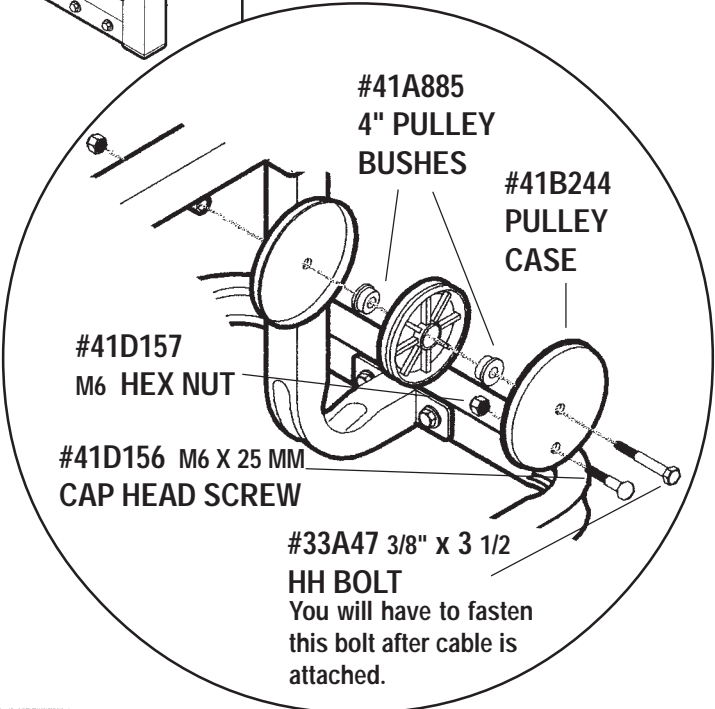

#33A53 x1



#41D157 x1



#41D156 x1



#33A47 x1

# 43

## CABLES

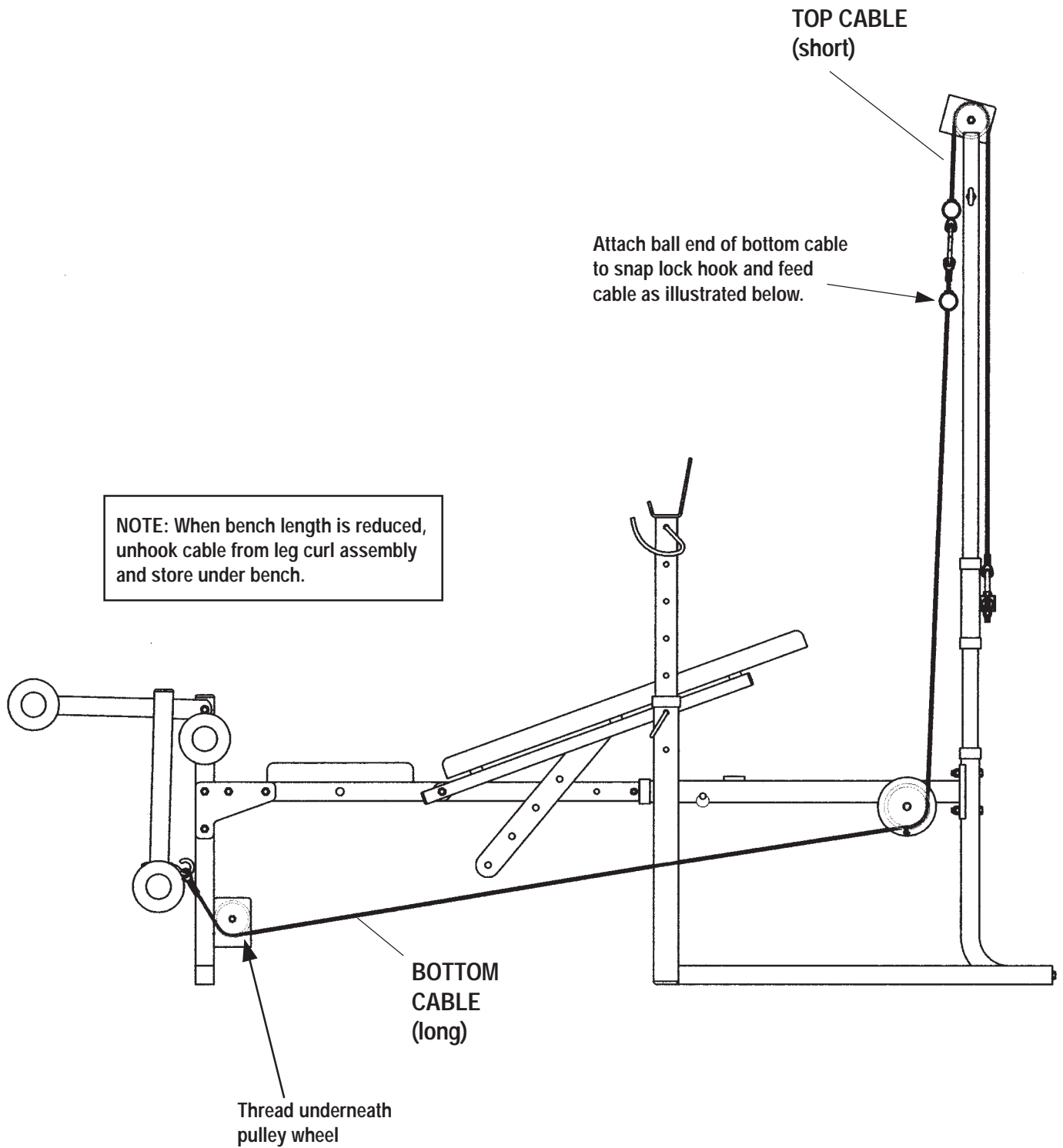

44

Reference to customers.  
When loading/unloading weights on the barbell, use the barbell hooks. To secure simply rotate the barbell hooks around and onto the top of the bar.

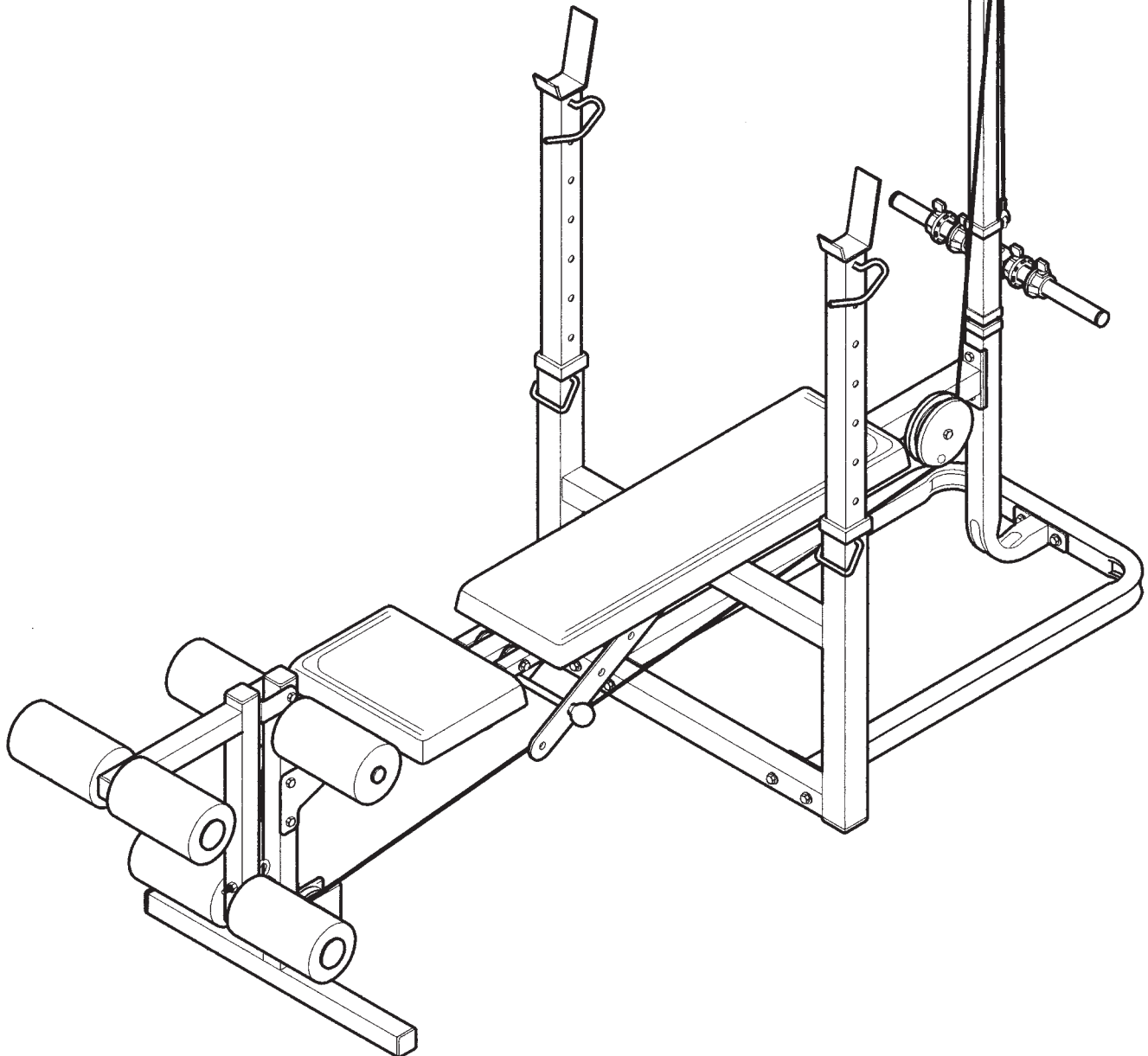
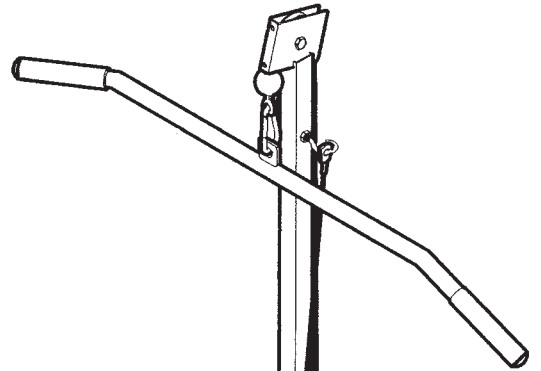
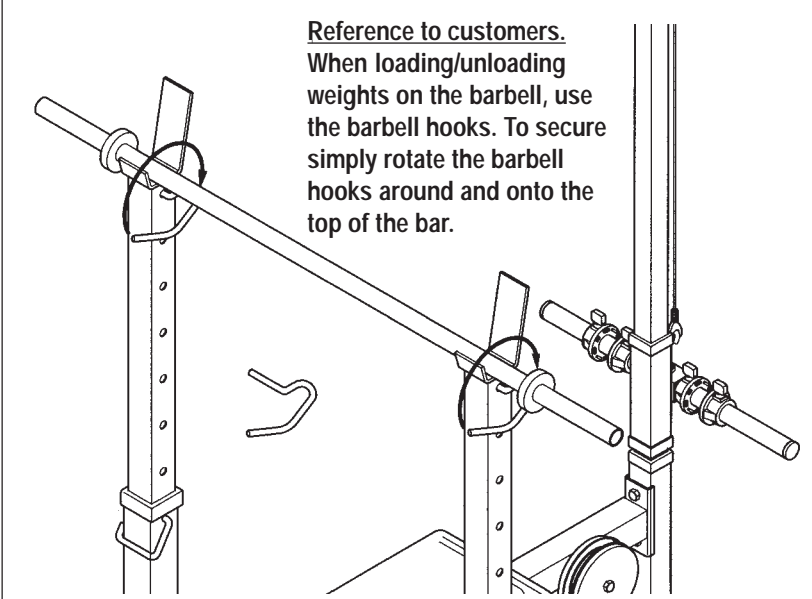

SHOULD YOU REQUIRE ANY ASSISTANCE REGARDING THIS PRODUCT PLEASE CONTACT YORK DIRECTLY.

# PARTS LIST

## BOX 1

KEY NO.	PART NO.	DESCRIPTION	Q'TY(PCS)
02	21E497661	18" Tube (Weight)	1
04	21E22081	Front leg assembly	1
05	21E5549	Horizontal bench mount	1
07	21E5376L	Left rear bench assembly	1
08	21E5376R	Right rear bench assembly	1
09	21E5550	Leg curl assembly	1
10	21E5547	Main assembly base	1
11	21E5548	Main assembly front support	1
12	21E5552	Main assembly rear support	1
14	21E53421	Sliding weight assembly	1
15	28E69G	Small upholstery grey	1
16	30E17G	Large upholstery grey	1
18	33E451	9004 Bracket	2
19	27A401	9300 + 9600 Enforcer foam roller	6
29	21E22901	Penny whistle	1
31	33E33	Barbell hook (zinc)	2
31A	01D169	Instruction manual	1
31B	01D06	Wall chart	1

BAG 9484A - uk BENCH		32E132A	Q'TY(PCS)
20	41B21	1" Rnd Int Foam caps (Black)	5
24	41A82	3" Pulley wheel	2
25	41B031	1 1/2" Int end cap	7
27	41B239	Spacer 3/8" thick 1" round	4
32	41D16	End tip 7.25mm Black 12354	2
33	41B401	5/16" Threaded cap	3
35	41B04	2" Int end caps	2
36	41B144	1 3/4" to 1 1/2" Reducer	1
30	41D155	12m Heavy duty pull pin	1
61	33A242	Ball Lock Pin	1

BAG 9485 - uk BENCH		32E133	Q'TY(PCS)
21	41D75	3/8" x 2 1/4" HH Bolt	10
22	33A53	3/8" Nylock Nut	20
23	33B63	3/8" SAE washer	20
26	33A591	3/8" x 5" HH Bolt	1
28	33A13	1/4" x 1 1/2" RHSMS	2
34	33A49	D Ring 158	2
40	33A47	3/8" x 3 1/2" HH Bolt	1
43	33A421	3/8" x 4 1/2" Eye bolt	3
44	33A51	3/8" Hex nut	3
47	33A56	3/8" x 2 1/2" HH bolt	1
48	33A45	3/8" x 13/16" Stripper bolt	2
49	33A33	5/16" Nyloc nut	2
50	33A48	3/8" x 2" HH Bolt	4
53	33A489	3/8" Snap lock hook	1
57	33A11	1/4" x 2" RHSMS	4
59	41D156	M6 Cap Head Screw	1
60	41D157	M6 Hex Nut	1

BAG 9486 - uk BENCH		32E134	Q'TY(PCS)
37	41B143	2" to 1 3/4" Reducer	2
38	41B145	1 1/2" to 1 1/4" Reducer	3
39	41B10	1" sq Int end cap	4
41	41B244	Canadian pulley case	2
42	41A885	Canadian pulley & 2x Bushes	1
45	41B01	1" Small round Int cap (Black)	3
46	41C091	Dumbbell collars (Black)	4
54	41A80	VKR Handgrip Hard	2
55	41B24	1 1/2" x 1/4" Plastic Washer (6mm thick)	2
56	41B246	1 1/2" x 1/4" Plastic Washer (3mm thick)	2
58	41D154	Rivet feet (18 x 10mm)	2

## BOX 2

KEY NO.	PART NO.	DESCRIPTION	Q'TY(PCS)
01	21E5545	16" Tube (Foam rollers)	3
03	21E53391	Barbell support arm	2
06	21E5546	Lat assembly	1
13	21E5551	Sliding bench mount tube (Spine)	1
17	21E22401	Lat Bar	1

BAG 9481 - uk BENCH		32E129	Q'TY(PCS)
51		Bottom Cable (L2955 x 3mm)	1
52		Top Cable (L1346 x 3mm)	1

# PARTS DRAWING

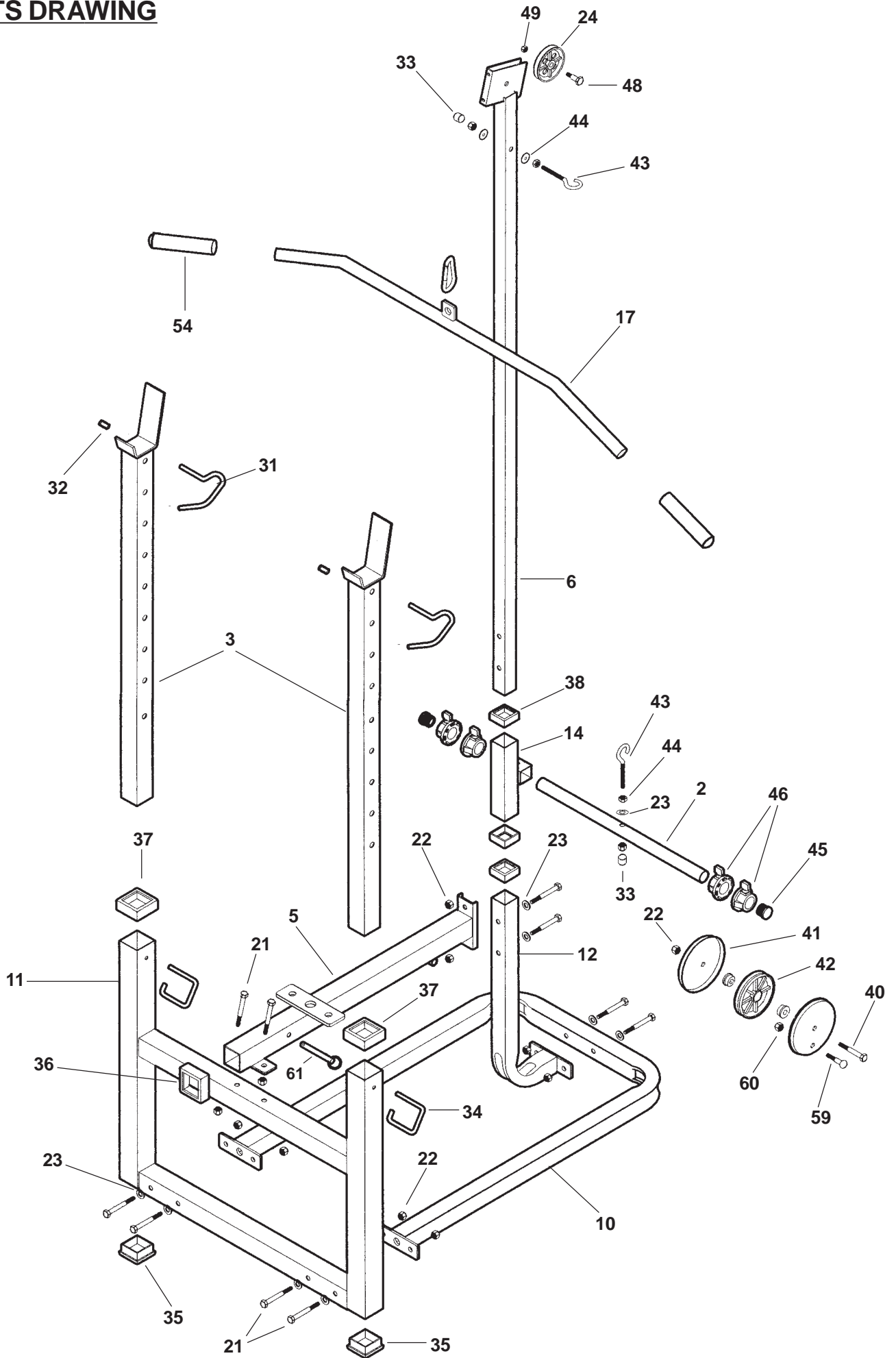

SHOULD YOU REQUIRE ANY ASSISTANCE REGARDING THIS PRODUCT PLEASE CONTACT YORK DIRECTLY.

# PARTS DRAWING

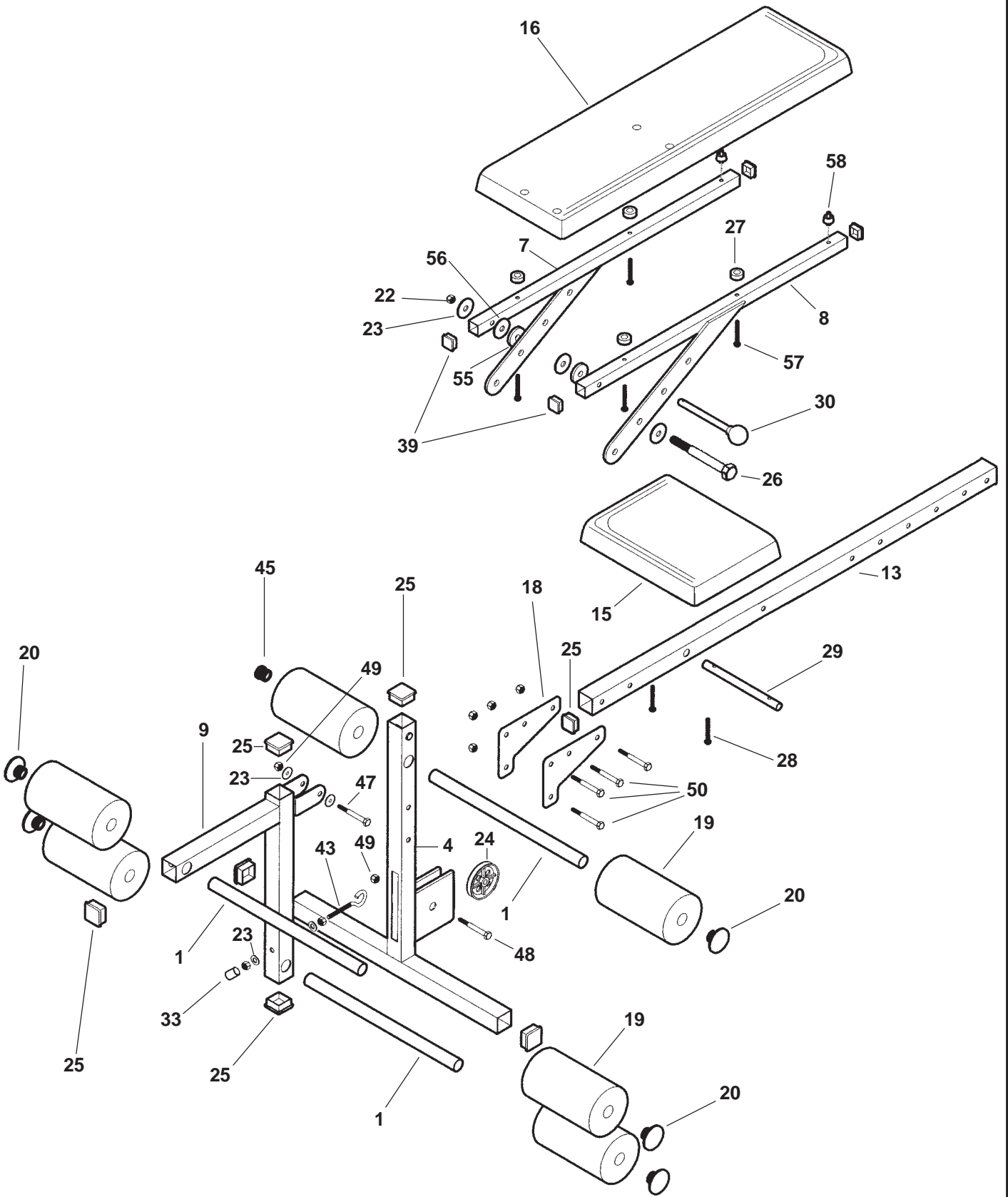

SHOULD YOU REQUIRE ANY ASSISTANCE REGARDING THIS PRODUCT PLEASE CONTACT YORK DIRECTLY.

# uk150 BENCH

Barbell supports should be approximately in-line with chest. As incline increases, bench & backrest position can be altered to ensure correct position.

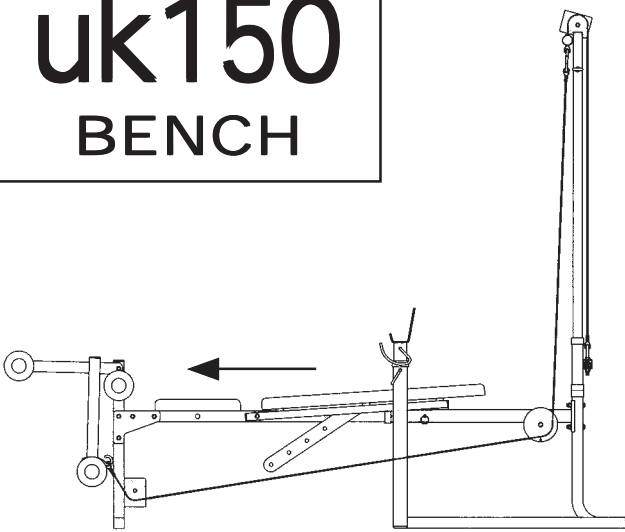

To use the leg unit, the bench must be extended out to the last hole. The cable will be tight.

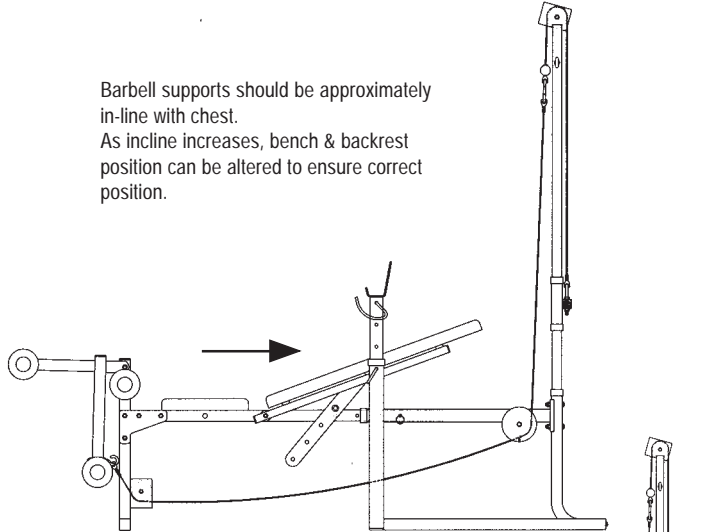

Seat position is closer for this incline.

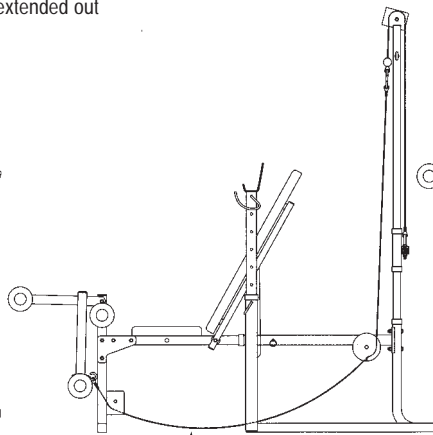
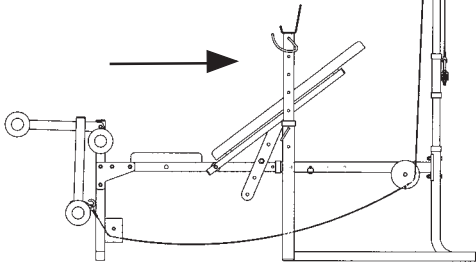

The cable may sometimes slacken. It needs to be tight for leg unit exercise only.

To achieve a comfortable press, the seat & backrest position can be adjusted so they are closer or further to the barbell support arms.

**NOTE: When bench length is reduced, unhook cable from leg curl assembly and store under bench.**

## INCLINE

## HORIZONTAL

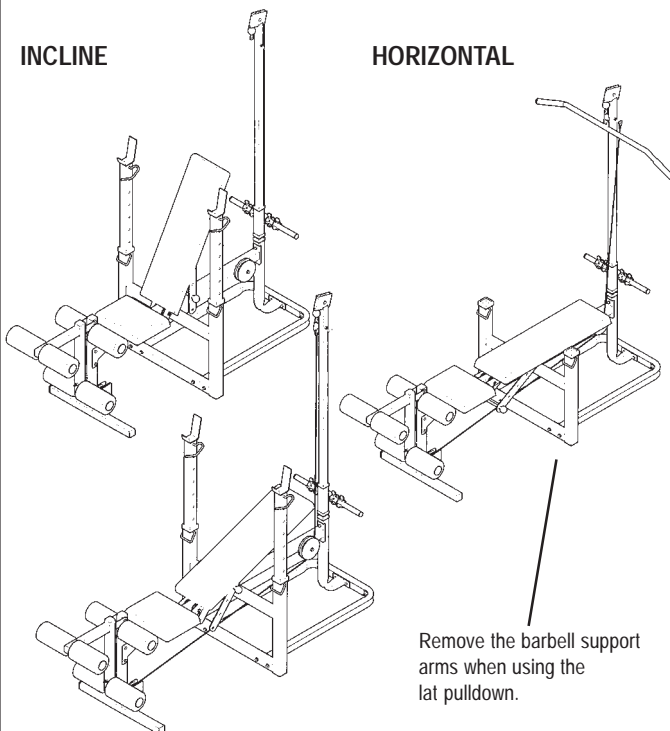

Remove the barbell support arms when using the lat pulldown.

## A USING YOUR LEG CURL

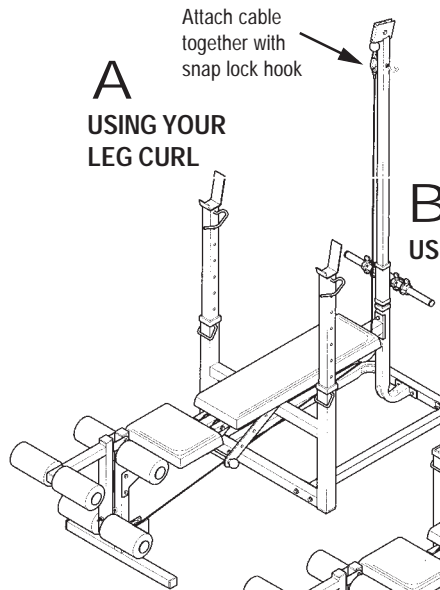

Attach cable together with snap lock hook

## B USING THE LAT

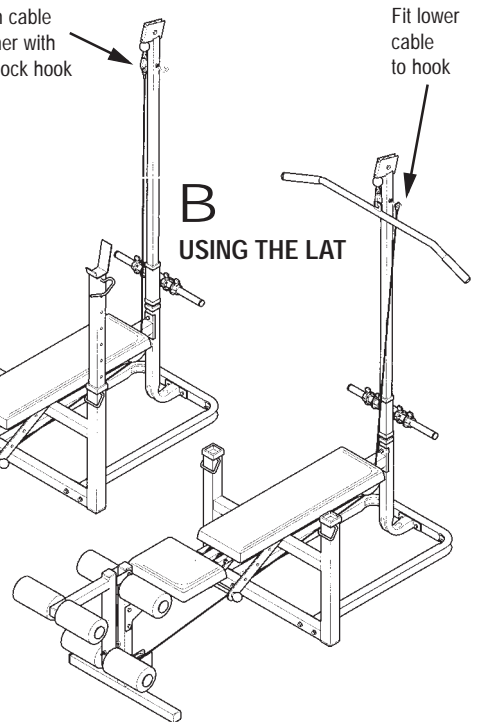

Fit lower cable to hook