



1001

PEC DEC



MODEL # 5027E

Attention:
This PEC DEC attachment is only compatible
with the York Home Gym Model No.5020

1001 YORK Fitness ASSEMBLY INSTRUCTIONS



1001

PEC DEC

MODEL # 5027E

ASSEMBLY INSTRUCTIONS

NOTE; MAXIMUM WEIGHT STACK LIMIT 65KGS.
(DO NOT ADD EXTRA WEIGHTS)
MAXIMUM WEIGHT OF USER = 100KG

This Box should contain the following:

- | | |
|----------------------|----------------------|
| 1 x Bag No.72 | 1 x Part 2290 |
| 1 x Bag No.9431 | 1 x Part 2208 |
| 1 x Bag No.74 | 1 x Part 22091R |
| 1 x Bag No.46 | 1 x Part 22091L |
| 1 x Instructions | 1 x Part 2230 |
| 1 x Pec Dec Decal | 1 x Part 2212 |
| 2 x Pec Foam Rollers | 1 x Large Upholstery |
| | 1 x Small Upholstery |

Before assembly, read instructions carefully as listed below. If these instructions are followed exactly, you will have no problems with assembly.

Tools Required:

- Slotted Screwdriver,
7/16"(11mm) Spanner, 1/2"(13mm) Spanner,
5/8" (16mm) Spanner, 9/16" (15mm) Spanner.

BAG 46		
Part No.	Description	Qty.
32B56	Pec Dec Cables	2

BAG 72		
Part No.	Description	Qty.
41B031	1 1/2" Sq. Int Cap - Black	2
41B07	1 1/4" Sq. Int Cap - Black	2
41B137	1 3/4" Sq. Int Cap - Black	2

BAG 9431A		
Part No.	Description	Qty.
33E37	Part 1241	1
33A11	1/4" x 2" RHSMS	2
33A13	1/4" x 1 1/2" RHSMS	2
33A47	3/8" x 3 1/2" HH Bolt	2
33A51	3/8" x Hex Nut	5
33A53	3/8" Nyloc Nut	4
33A56	3/8" x 2 1/2" HH Bolt	1
41B07	1 1/4" Square int. cap blk.	4
33A421	3/8" x 4 1/4" Eye Bolt	3
41B402	3/8" Thread Cap	4

BAG 74		
Part No.	Description	Qty.
33E30	Part 1230	2
33A03	1/4" Nyloc Nut	4
33A14	1/4" x 1 3/4" RHSMS	4
33A32	5/16" Hex Nut	2
33A45	3/8" x 13/16" Stripper Bolt	2
33B63	3/8" Sae Washer	2
41A82	3" Black Pulley Wheel	2
41B400	1/4" Thread Cap	4

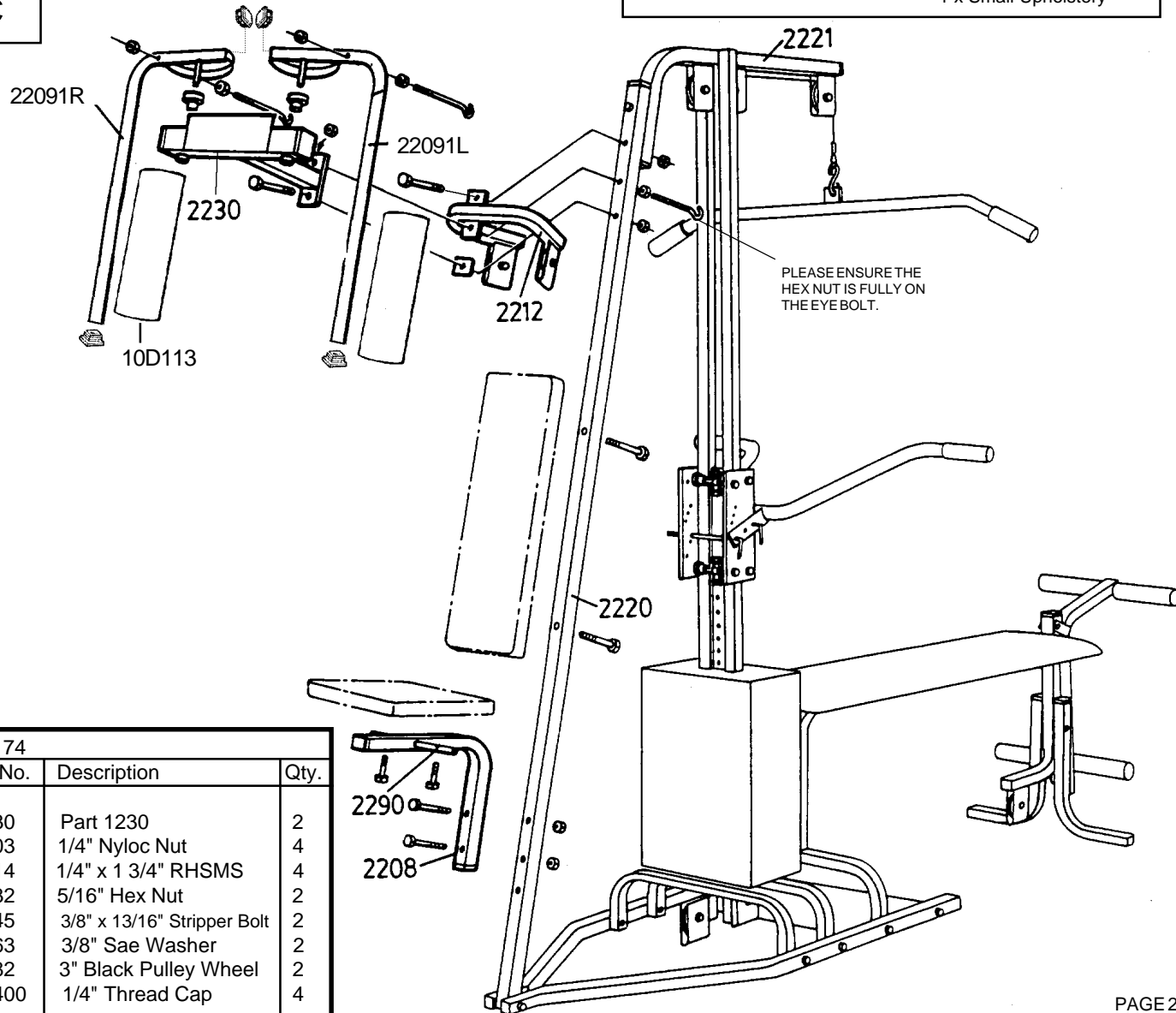

Locate Part 2212 and using Bag 74, assemble Parts 1230 as per drawing (1).
Install two 1 1/4" square caps from Bag 72.

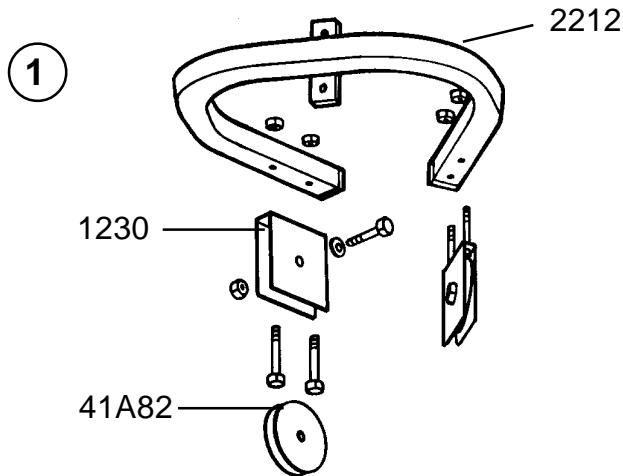

To attach Part 2212 to Part 2220, the lower bolt that connects Part 2220 to Part 2221 must first be removed. Using this same bolt, attach Part 2212 to Part 2220 and Part 2221, and replace the nut finger tight.

Locate Part 2230 and from Bag 72 install two 1 3/4" square caps and stick the decal provided to front plate.

From Bag 9431 take one 3/8" x 4 1/4" eyebolt and one 3/8" Hex nut and screw the nut up the full length of the thread. Insert this eyebolt through Part 2220 and into the bottom hole on the bracket on Part 2212 and also into the top hole on the bracket on Part 2230. Attach one 3/8" Nyloc nut finger tight. Note that the opening in the eyebolt should be at the top.

From Bag 9431 take one 3/8" x 2 1/2" Hex Head Bolt and one 3/8" Nyloc Nut along with one Part 1241. Using Part 1241 as a packing piece, insert the bolt through the bottom hole on the bracket on Part 2230 and through the hole in Part 1241 and on through Part 2220. Attach the one 3/8" Nyloc Nut finger tight.

Take the large piece of upholstery and attach it to Part 2220 using two 1/4" x 2" machine screws.

Take the small piece of upholstery and attach it to Part 2208 using Part 2290 and two 1/4" x 1 3/4" machine screws.

Note that the heads of the machine screws should sit in the dimpled recess on Part 2290.

Install two 1 1/2" square caps from Bag 72 into Part 2208 and attach to Part 2220 using two 3/8" x 3 1/2" Head Head Bolts and two 3/8" Nyloc nuts.

Note that this seat is adjustable and can be used in two positions. Check which one suits the user best.
Now align the parts assembled and tighten all nuts, bolts and machine screws.

PEC ARM ASSEMBLY

Parts 22091R and 22091L take 4 internal black caps and install them in the tubing as shown in the main diagram.

From Bag 9431A take two 3/8" x 4 1/4" eyebolts and two 3/8" Hex nuts. Screw one Hex nut up the full length of the thread on each eyebolt.

Now insert eyebolts into Pec arms as shown in Drawing (2) and with the two 3/8" Hex nuts remaining, put one on each of the eyebolts finger tight.



Take up each arm assembly in turn and insert it into the nylon bushings in the top of Part 2230 as shown in the main diagram.

Take the cables from Bag 46 and attach one to each eyebolt on the arms. Thread the cable through the pulley brackets on Part 2212 and then lead them down to the weight stack on the 1001 Home Gym and hook the loops of the cables over the quick change hook bolt.

Now adjust any slack in the cables by altering the eyebolt positions on the arms. When the correct tension is reached, make sure that the opening in the eyebolts are at the top before tightening the nuts up to the tubing.

Finally check the equipment over and make sure that all nuts, bolts and machine screws are tight and install the thread protector caps provided.

Warning:

Wire ropes wear. It is your responsibility to inspect daily and replace when starting to fray. Write to the address below for replacements.

Always use your gym on a flat level surface.

Always use your gym in adequate space e.g. at least 2ft. (60cm) clearance each side.

We recommend you never lift weights alone. There should always be someone available to assist you. Training with others can help motivate you.

Care and Maintenance: Before every training session the equipment should be inspected for loose, worn or missing parts. To prevent injury, replace doubtful parts before resuming usage of the equipment.

Upholstery: Use a warm, damp cloth to keep clean.



YORK BARBELL (U.K.) LTD.
CHURCHILL WAY,
DAVENTRY,
NORTHANTS, NN11 4YB
GENERAL ENQUIRIES
TEL: (01327) 701800
CUSTOMER SERVICE HELPLINE
TEL: (01327) 701824
FAX: (01327) 706704
E-MAIL: helpdesk@yorkfitness.co.uk

www.yorkfitnessworldwide.com

SHOULD YOU REQUIRE ANY ASSISTANCE REGARDING WORN, MISSING OR DEFECTIVE PARTS CONTACT US DIRECTLY.

