

YORK[®] *Fitness* 1101

HOME GYM MODEL 7030

MODEL 7030 ASSEMBLY INSTRUCTIONS

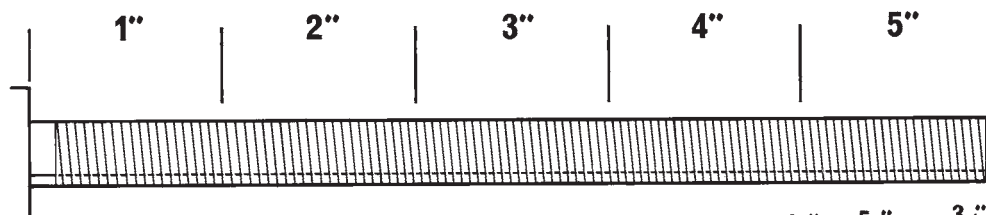
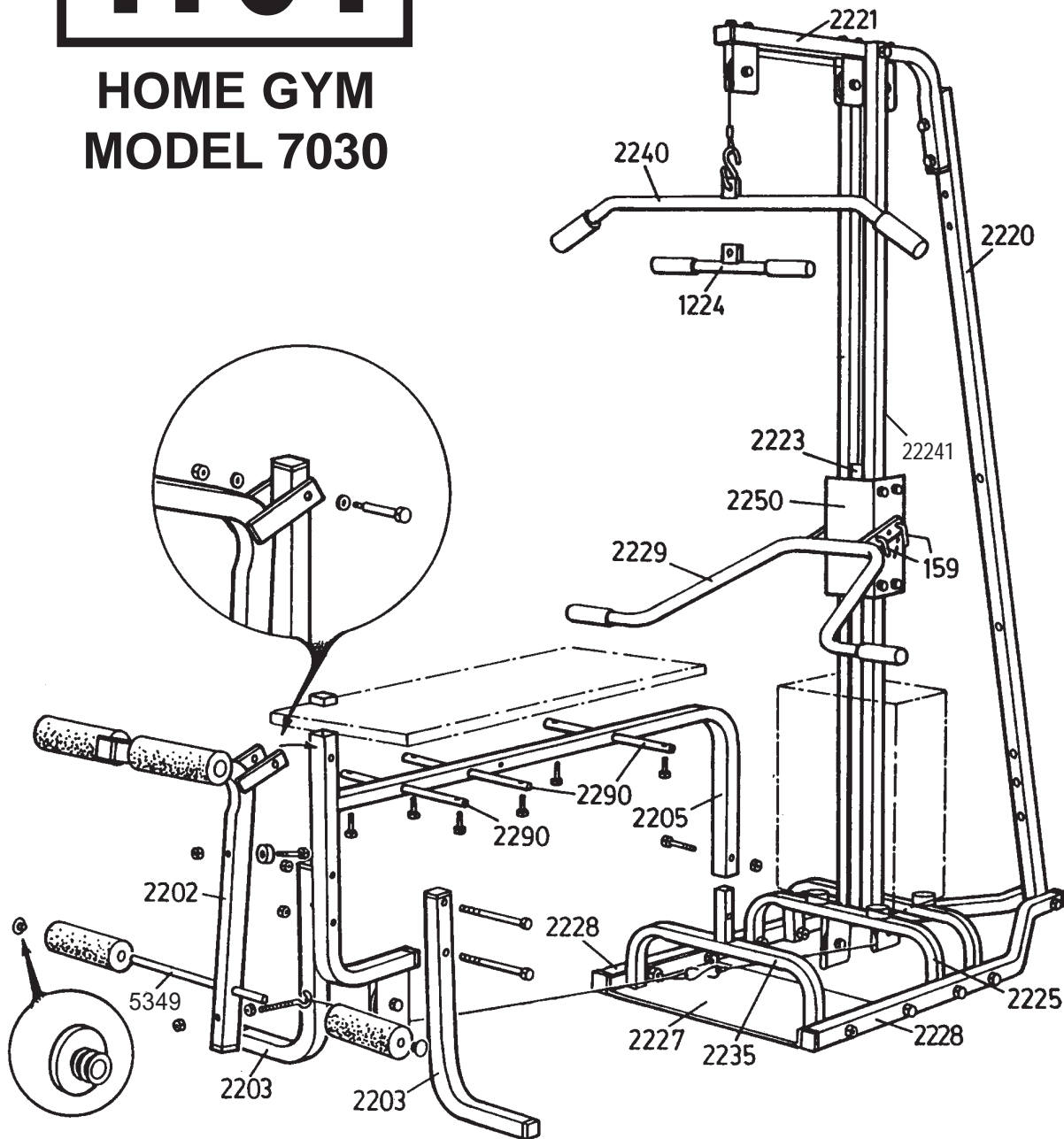
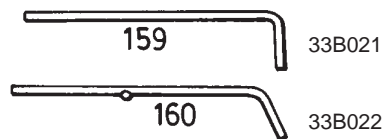

SECTION 1

NOTE: MAXIMUM WEIGHT STACK LIMIT 65KGS. (DO NOT ADD EXTRA WEIGHTS) MAXIMUM WEIGHT OF USER = 100KG
 Before assembly, read each section carefully. If these instructions are followed exactly you will have no problems with assembly. Tools required: Slotted Screwdriver and 2 adjustable Spanners or
 7/16"(11mm) Spanner
 1/2"(13mm) Spanner
 9/16"(15mm) Spanner
 5/8"(16mm) Spanner

| BOX1 | | |
|----------|--------------------------|------|
| Part No. | Description | Qty. |
| 32B85A | Bag 75A | 1 |
| 32B93A | Bag 83A | 1 |
| 27E032 | Jet Lag | 4 |
| 28E66 | Upholstery 1101 | 1 |
| 21E2290 | Upholstery Support Tube | 3 |
| 21E2202 | Leg Curl | 1 |
| 21E2203 | Front Feet | 2 |
| 21E2205 | Main Upholstery Support | 1 |
| 21E2235 | Lower Upholstery Support | 1 |
| 21E2229 | Handle Bar | 1 |
| 21E5349 | Leg Foam Tube | 2 |

| BAG83A | | |
|----------|----------------------------|------|
| Part No. | Description | Qty. |
| 01A49 | 2001 Weight Stickers | 1 |
| 01A481 | 1001 Exercise Manual | 1 |
| 01D162 | 1101 Assembly Instructions | 1 |
| 01D163 | 1101 Glide Decal | 1 |
| 01D04 | Warning Leaflet | 1 |

| BAG75A | | |
|----------|-----------------------------|-----|
| Part No. | Description | Qty |
| 33A03 | 1/4" Nyloc Nut | 1 |
| 33A14 | 1/4" x 1 3/4" RHSMS | 6 |
| 33A11 | 1/4" x 2" RHSMS | 1 |
| 33A32 | 5/16" Hex Nut | 1 |
| 41B400 | 1/4" Thread Cap | 1 |
| 33A33 | 5/16" Nyloc Nut | 1 |
| 33A51 | 3/8" Hex Nut | 1 |
| 33A53 | 3/8" Nyloc Nut | 4 |
| 33A48 | 3/8" x 2" H.H. Bolt | 1 |
| 33A59 | 3/8" x 4 1/2" H.H. Bolt | 2 |
| 33A45 | 3/8" x 13/16" Stripper Bolt | 1 |
| 33A46 | 3/8" x 2" Stripper Bolt | 1 |
| 33A421 | 3/8" x 4 1/4" Eye Bolt | 1 |
| 33B63 | 3/8" SAE Washer | 3 |
| 41B402 | 3/8" Thread Cap | 1 |
| 41B07 | 1 1/4" SQ. Int. Cap (Black) | 6 |
| 41B031 | 1 1/2" SQ. Int. Cap (Black) | 4 |
| 41A83 | Rubber Bumper | 1 |
| 41A82 | 3" Pulley Wheel | 1 |
| 41B212 | 1" Blue Foam Cap | 4 |
| 41A81 | 1 1/4" Black Hand Grip | 2 |

Take upholstered piece and place upside down. Place Pt.2205 on top of upholstery and put three x Pt.2290 (5/8" round tubing) through three large holes in Pt.2205 so that the holes in the round tubing line up with holes in the upholstery and Pt. 2205 is in the middle. Insert six x 1/4"x 1 3/4" slotted screws through holes in Pt.2290 and screw evenly into holes in the upholstery until secured. Insert Pt.2235 into Pt.2205. Put one x 3/8" x 2" hex head bolt through the hole in Pt.2235 and put one x 3/8" nyloc nut on finger tight.

Assemble pulley wheel in Pt.2205 as shown in (A) using:
 one x 3" pulley wheel
 one x 3/8" washer
 one x 5/16" hex nut
 one x 3/8" x 13/16" stripper bolt
 Pulley wheel should move freely within bracket.

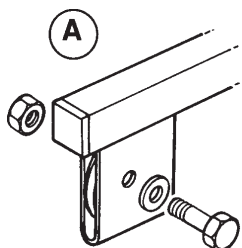

Attach finger tight two x Pt.2203 to Pt.2205 using:
 two x 3/8" x 4 1/2" hex head bolts
 and two x 3/8" nyloc nuts
 Install four x 1 1/4" and one x 1 1/2" square internal caps.
 Install one x round rubber bumper into Pt.2202 using one x 1/4" x 2" slotted screw and one x 1/4" nyloc nut.

Take one x 4 1/4" eyebolt and screw on one x 3/8" hex nut until it can go on no further. Insert eyebolt into back of Pt.2202 and put on remaining one x 3/8" nyloc nut. Install thread cap. Install remaining black caps into Pts.2202,2203,and 2205.

Attach Pt.2202 to Pt.2205 as in drawing B using:
 one x 3/8" x 2" stripper bolt
 one x 5/16" nyloc nut
 two x 3/8" washers.



Leg curl must move freely so **do not over tighten**

Insert two Pts.5349 into Pt.2202, slide on foam rollers and install four large red foam caps into the tubing.

Now have someone sit on the bench while you tighten all the remaining bolts. This will level the bench. Bolt in PT.2235 must be tightened until it will not move inside Pt.2205.

Install 41A81 Hard Hand Grips onto Pt.2229.

Now open Box No.2 which contains the following parts:

| BOX 2 | | |
|----------|-------------|------|
| Part No. | Description | Qty. |
| 32B37 | Bag 27 | 1 |
| 32B86 | Bag 76 | 1 |
| 32B87 | Bag 77 | 1 |
| 32B88 | Bag 78 | 1 |
| 21E2225 | Crab | 1 |
| 21E2227 | Base Plate | 1 |
| 21E2250 | Channel | 1 |

Locate Bag No.27 and check contents as listed :

| BAG 27 | | |
|----------|---------------------|------|
| Part No. | Description | Qty. |
| 33A03 | 1/4" Nyloc Nut | 4 |
| 33A14 | 1/4" x 1 3/4" RHSMS | 4 |
| 41A83 | Rubber Bumper | 4 |

Install Pts. from Bag 27 into Pt.2225 as shown in C.

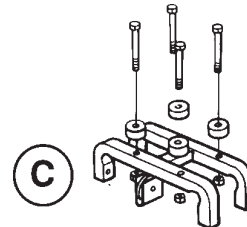

Locate Bag 76 and check contents as listed:

| BAG 76 | | |
|----------|-----------------------------|------|
| Part No. | Description | Qty. |
| 33A32 | 5/16" Hex Nut | 2 |
| 33A45 | 3/8" x 13/16" Stripper Bolt | 2 |
| 33B63 | 3/8" SAE Washer | 2 |
| 41A82 | 3" Pulley Wheels | 2 |

Turn Pt.2225 upside down and install the two pulley wheels as you did before.
 Put Bag 77, 78, and Pt. 2227 to one side.

SECTION 2

Now open Box 3 which contains the following parts:

| BOX 3 | | |
|----------|---|------|
| Part No. | Description | Qty. |
| 32B39 | Bag 29 Cables | 1 |
| 32B89 | Bag 79 | 1 |
| 32B90 | Bag 80 | 1 |
| 32B91A | Bag 81A | 1 |
| 21E2220 | Main Stem | 1 |
| 21E2221 | Top Pulley Support | 1 |
| 21E2223 | Tear Drop | 1 |
| 21E2224 | Weight Holder Stacks | 2 |
| 33B021 | Pin 159 | 2 |
| 33B022 | Pin 160 | 1 |
| 21E2228 | Side Rails | 2 |
| 21E2240 | Large Lat Bar | 1 |
| 21E1224 | Small Lat Bar | 1 |
| 32E68 | Bag 9432 (This bag contains collars & allen key for locking your gym. | 1 |

Locate Bag 77 and check contents as listed:

| BAG 77 | | |
|----------|-----------------------------|------|
| Part No. | Description | Qty. |
| 33A33 | 5/16" Nyloc Nut | 3 |
| 33A382 | 5/16" x 1 1/2" HH Bolt | 3 |
| 33A53 | 3/8" Nyloc Nut | 9 |
| 33A60 | Part 1243 3/8" Threaded Rod | 4 |
| 41B08 | Pt.1235 RollerGlide | 8 |
| 33A436 | Glide Quick Change Bolt | 1 |
| 33B38 | Pt.1242 Glide Stampings | 2 |

Assemble Pt.2223 (tear drop piece) to Pt.2250 using the parts listed above and following diagram D.

- (A) Install two long bolts and four rollers in the back of the glide channel and tighten.
- (B) Attach Pt.2223 (with flat side facing the opening of the channel) using one x quick change bolt, one x 3/8" nyloc nut and one Pt.1242 glide stamping.
- (C) Install bolts and rollers into the front of Pt.2223 and tighten, then put this part to one side.

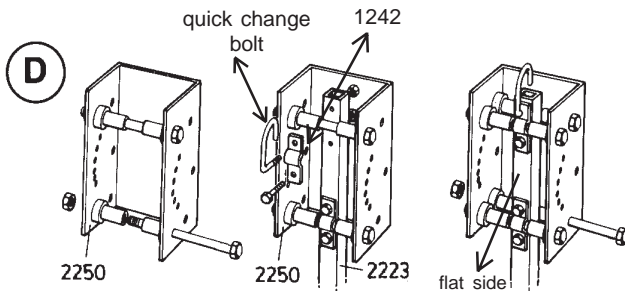

Locate Bag 79 and check contents as listed:

| BAG 79 | | |
|----------|-----------------------------|------|
| Part No. | Description | Qty. |
| 33A03 | 1/4" Nyloc Nut | 6 |
| 33A14 | 1/4" x 1 3/4" RHSMS | 6 |
| 33A33 | 5/16" Nyloc Nut | 3 |
| 33A45 | 3/8" x 13/16" Stripper Bolt | 3 |
| 33B63 | 3/8" SAE Washer | 3 |
| 41A82 | 3" Pulley Wheels | 3 |
| 33E30 | 1001 Pt.1230 Painted | 3 |

Assemble Pt.2221 as per drawing E using Bag 79.

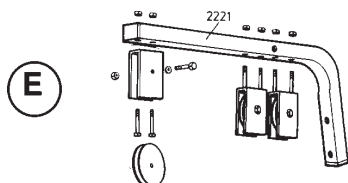

Locate Bag 81A and check contents as listed:

| BAG 81A | | |
|----------|-------------------------|------|
| Part No. | Description | Qty. |
| 27A51 | 6" Grip 0623150 | 4 |
| 41B012 | 1" Rnd. Int. Cap (Blue) | 4 |

Locate Bag 78 and check contents as listed:

| BAG 78 | | |
|----------|-----------------|------|
| Part No. | Description | Qty. |
| 33A51 | 3/8" Hex Nut | 4 |
| 33A53 | 3/8" Nyloc Nut | 4 |
| 33A573 | 1001 Hook Bolt | 4 |
| 41B402 | 3/8" Thread Cap | 4 |

Assemble two Pt.2228 to Pt.2227 using Bag 78 as in drawing F. Spin one nut to end of thread on hook bolt, insert through Pt.2228 and Pt.2227 and put nyloc nut on end of hook bolt. Do not fully tighten yet.

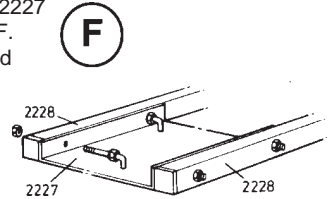

Locate Bag 80 and check contents as listed:

| BAG 80 | | |
|----------|----------------------------|------|
| Part No. | Description | Qty. |
| 33A53 | 3/8" Nyloc Nut | 9 |
| 33A47 | 3/8" x 3 1/2" HH Bolt | 6 |
| 33A59 | 3/8" x 4 1/2" HH Bolt | 2 |
| 33A591 | 3/8" x 5" HH Bolt | 1 |
| 41B031 | 1 1/2" Sq. Int. Cap(Black) | 7 |
| 41B402 | 3/8" Thread Cap | 7 |

Place Pt.2225 between the two Pts.2228 and assemble finger tight using four x 3/8" x 3 1/2" bolts and four x 3/8" nyloc nuts as in drawing G.



Install six black internal caps into Pt.2228 and Pt.2221.

At this point you will need someone to help you.

Attach finger tight Pt.22241 to Pt.2225 using one x 3/8" x 4 1/2" bolt and one x 3/8" nyloc nut (diag.H). **NOTE:** The holes that are the shortest distance from the end of Pt.22241 should be at the top of the unit.



Assembly of weights and glide channel:

Open Box No.4 which contains vinyl weights. The flat side of the weight should be on the bottom and is marked "This Side Down".



There is a black cap on the end of each weight and as you slide the weights onto Pt.22241 make sure that you alternate the cap from the left to the right side. If this is not done properly, you will have trouble when installing the weight selector pin. (Drawing I).

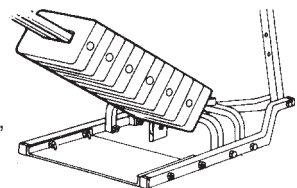

Slide Pt.2250 onto Pt.22241, down to the weights. While your assistant is holding Pt.22241 install (finger tight) Pt.2221 in the top of Pt.22241 using one x 3/8" x 4 1/2" bolt and 3/8" nyloc nut. Continue to hold Pt.22241.

SECTION 3

Install one black cap in the top of Part 2220. Take the end of Pt.2220 with only one hole and attach between Pts.2228 using one 3/8" x 5" bolt and one 3/8" nyloc nut.

Attach Pt. 2220 to the back of Pt.2221 using two 3/8" x 3 1/2" bolts and two x 3/8" nyloc nuts.

Now that you have assembled the unit you must align and tighten everything.

Tighten the following: -

Parts 2225 and 22241
22241 and 2221
2228 and 2227
2225 and 2228
2228 and 2220
2220 and 2221

Attach the decal to Pt.2250 and the weight stickers to the weights.

INSTRUCTIONS FOR USE

Locate Bag No.29 (Cables).

For installation of Cables see Drawing J.

We recommend that the cables be removed from the machine when not in use.

Additional holes in Pt.2220 are provided for the attachment of the York 1101 PEC DEC which is sold separately.

For safety reasons, when bench pressing, the rear legs of the bench should be located on top of the base plate.

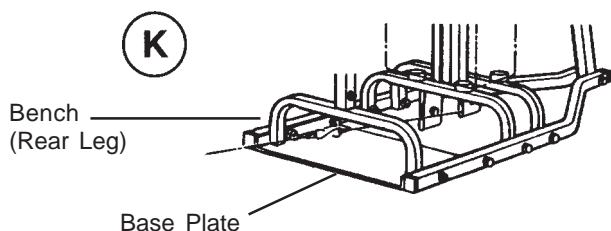

To use leg curl attachment, move bench toward weight stack, attach cable B to cable D using an 'S' hook (E). Attach other end of cable B to eyebolt on Pt.2202 using the remaining 'S' hook. Pull bench away from weight stack until cables are tight.

For safety reasons -

Remove the lat bar (Pt. 2240) after use or it can hit you on the head when performing other exercises.

When using short pulley bar for rowing exercise keep toes clear of weights.

To adjust angle of handlebars change position of rear pin to one of the 6 holes available.

WARNING:

Wire cables wear. It is your responsibility to inspect daily and replace when starting to fray. Write to the address opposite or telephone our helpline for replacements.

Always use your gym on a flat level surface.

Always use your gym in adequate space e.g. at least 2ft. (60cm) clearance each side.

Care and maintenance: Before every training session the equipment should be inspected for loose, worn or missing parts. To prevent injury, replace doubtful parts before resuming usage of the equipment.

Upholstery: Use a warm damp cloth to keep clean.

| BAG 29 (Cables) | | |
|------------------|------|------|
| Description | | Qty. |
| B = Short Cable | 42" | 1 |
| C = Medium Cable | 53" | 1 |
| D = Long Cable | 134" | 1 |
| E = 'S' - Hooks | | 2 |

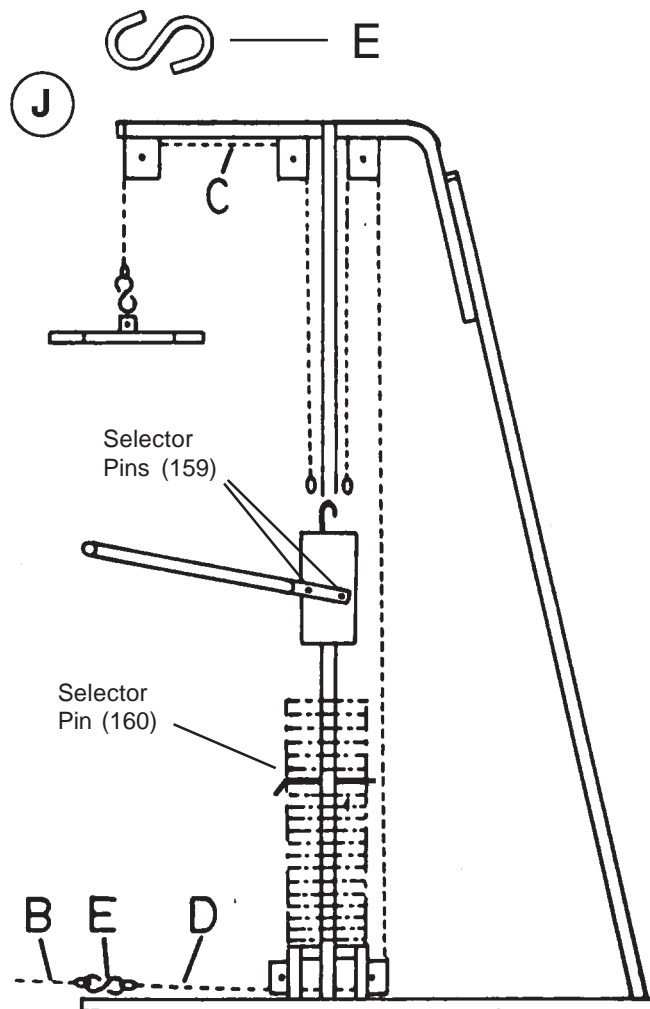

SHOULD YOU REQUIRE ASSISTANCE REGARDING WORN, MISSING OR DEFECTIVE PARTS PLEASE CONTACT OUR HELPLINE

WE WILL REQUIRE THE BATCH NUMBER (LOCATED ON A STICKER, ON THE BACK OF THE UPHOLSTERY).

IF PARTS ARE MISSING FROM THE BAG THEN WE WILL ALSO REQUIRE THE INFORMATION PRINTED ON THE BAG.



YORK BARBELL (U.K.) LTD.
CHURCHILL WAY, DAVENTRY,
NORTHANTS, NN11 4YB, ENGLAND
GENERAL ENQUIRIES

TEL: (01327) 701800
CUSTOMER SERVICE HELPLINE
TEL: (01327) 701824
FAX: (01327) 706704
E-MAIL: helpdesk@yorkfitness.co.uk

www.yorkfitnessworldwide.com



WARNINGS

PLEASE READ THIS SHEET CAREFULLY BEFORE STARTING TO USE THE ENCLOSED EXERCISE EQUIPMENT.

1. Always consult your doctor before undertaking any exercise program.
2. Ensure that all nuts and bolts are fully tight before using any exercise equipment.
3. Always wear suitable clothing and footwear e.g. tracksuit and training shoes.
4. Children should not be allowed on or around the machinery or equipment, even when not in use.
5. After eating allow 1 to 2 hours prior to exercising.
6. Always warm up well before exercising as this will prevent straining muscle.
7. Always read and follow the manufacturers assembly and user instructions.
8. Remove jewellery, rings, chains and pins before exercising.
9. Check for full engagement of locking pins.
10. Where applicable make sure weight retention collars are fully tightened.
11. Give special attention to the cables, pulleys and locking devices as they may wear.
12. Injuries to health may result from incorrect or excessive training.
13. Check that any of the adjustment devices are not projecting.
14. Always use your gym on a flat level surface.
15. Always use your gym in adequate space e.g. at least 2ft. (60cm) clearance on each side.
16. We recommend you never lift weights alone. There should always be someone available to assist you. Training with others can help motivate you.

N.B. this list should not be taken as exhaustive, there may well be other warnings needed on specialised equipment.

HOW TO LOCK YOUR GYM

IMPORTANT NOTICE

This Allen key and collar have been supplied to enable you to lock your gym to prevent unauthorised use.

It is your responsibility to make sure your gym is not used without permission or supervision.

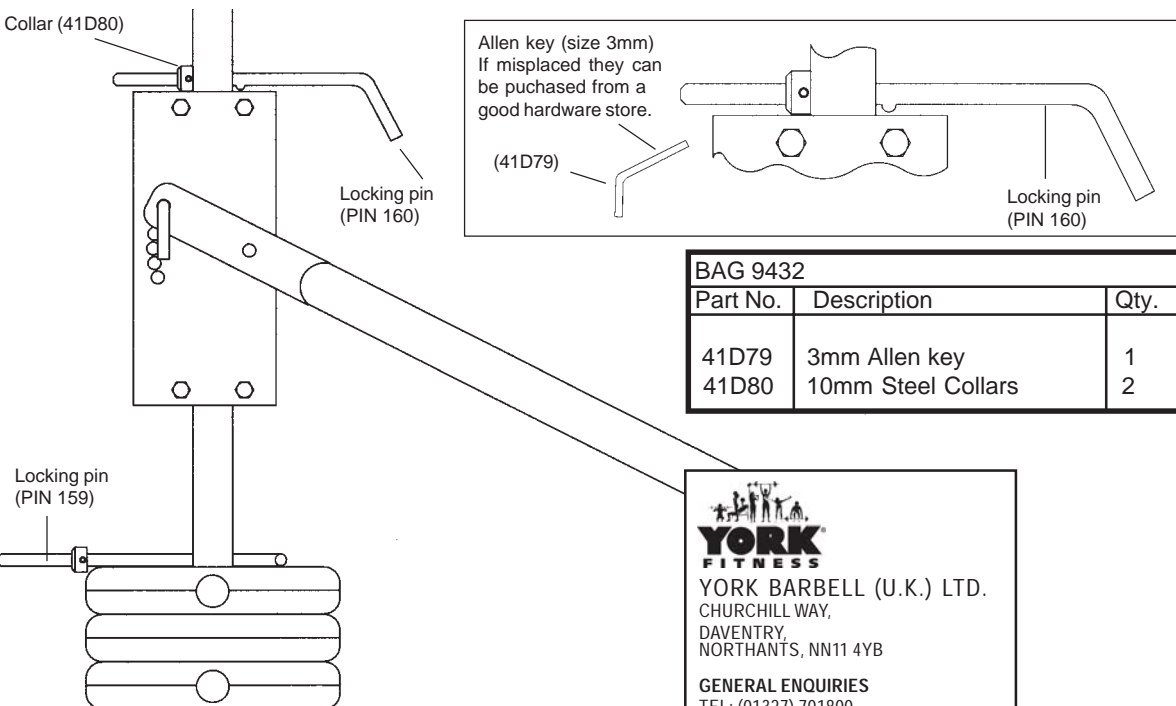

| BAG 9432 | | |
|----------|--------------------|------|
| Part No. | Description | Qty. |
| 41D79 | 3mm Allen key | 1 |
| 41D80 | 10mm Steel Collars | 2 |

YORK BARBELL (U.K.) LTD.
 CHURCHILL WAY,
 DAVENTRY,
 NORTHANTS, NN11 4YB

GENERAL ENQUIRIES
 TEL: (01327) 701800
 CUSTOMER SERVICE HELPLINE
 TEL: (01327) 701824
 FAX: (01327) 706704
www.yorkfitnessworldwide.com