

**401
GYM**

**MODEL
5070 - UK**

ASSEMBLY INSTRUCTIONS #01A687

401 YORK *Fitness* ASSEMBLY INSTRUCTIONS



MODEL # 5070 - UK
401 GYM
ASSEMBLY INSTRUCTIONS

Before assembly, this must be read before you start assembling this unit. Great care has been taken in design and how to assemble this unit. All bags of nuts and bolts have been packed with ease of assembly in mind. You must follow the assembly instructions exactly as outlined. You will need at least **one** person to help you assemble this unit, two would be better. Assemble this unit starting at the beginning and work to the end. The assembly instructions are set out so that you are only doing one section at a time, therefore you will finish one section and move on to the next. Do **not** do what most people do, when all else fails they read the assembly instructions. If something is missing when assembling this unit, you must notify us of the part number of the exact nut, bolt or part that is missing and the **colour** of the model you purchased.

To help you assemble this unit we have used line drawings. Check the line drawings for the exact positioning of the parts. This unit will need to be checked at least once a week for wearing wire ropes, nuts and bolts that can work loose, upholstered pieces working loose and wear on pivot assemblies.

WARNING: WIRE ROPES DO WEAR OUT!!

The way to check the wire ropes is to run your fingers lightly along them and if you start to feel they are frayed, please write to use for replacements. This is for your own safety.

WARNING: YOU ARE RESPONSIBLE FOR YOUR OWN SAFETY!!

If the box containing the parts for the 401 gym was unopened when you purchased it and there is a shortage, please notify us by mail and send a copy of your receipt. If the box was opened and there is a shortage, the dealer is responsible. Please indicate to us the part number which is missing and we will return the missing part by return mail.

CANADA
 YORK BARBELL CO LTD
 1450 SOUTH SERVICE ROAD WEST
 OAKVILLE, (TORONTO) ONTARIO,
 CANADA L6L 5T7
 TEL: (905) 827-6362
 FAX: (905) 827-9593

AUSTRALIA
 YORK BARBELL (AUST.) PTY. LTD.
 UNIT 1, LOT 2
 SWAFFHAM ROAD, MINTO,
 N.S.W. 2566, AUSTRALIA
 TEL: (02) 9603 8444
 FAX: (02) 9603 8555

U.K.
 YORK BARBELL (U.K.) LTD
 CHURCHILL WAY
 DAVENTRY, NORTHANTS
 ENGLAND NN11 4YB
 TEL: (01327) 701800
 FAX: (01327) 706704

WARNING:

Always hold the weight stabilizer pin with one hand when you are changing the weight selector pin. This is a safety precaution.

WARNING:

It is very important that you do not throw out or destroy these assembly instructions as you never know when you will move or wish to relocate this unit. These must be kept on hand for future reference.

EXTRA TRAINING RESISTANCE

This unit incorporates a multiplying system which increases the weight resistance up to 50% on the PRESS and PEC exercises.

TOOLS NEEDED TO ASSEMBLE 401 GYM:-

- | | | |
|----------------|-----------|------|
| a) wrenches :- | 2 x 9/16" | 14mm |
| | 2 x 3/4" | 19mm |
| | 1 x 5/8" | 16mm |
| | 1 x 1/2" | 13mm |
| | 1 x 7/16" | 11mm |

b) large screwdriver c) hammer **PLIERS SHOULD NOT BE USED!!**
 This machine should be assembled finger tight in the beginning to allow for proper alignment.

Warnings

- Consult your doctor** before participating in this or any exercise program.
- Never lift weights alone.** There should always be someone readily available to help in case of difficulty.
- Ensure that all nuts and bolts** are fully tight before using any exercise equipment.
- Always wear suitable clothing and footwear** e.g. track suit and training shoes.
- Children should not be allowed** on or around the machinery or equipment, even when not in use.
- Do not eat large meals before exercising.**
- Always warm up well before exercising** as this will prevent muscle strain.
- Remove jewellery, rings, chains and pins before exercising.**
- Check for full engagement of locking pins.**



MODÈLE # 5070 - UK
401 GYM
ASSEMBLAGE

LIRE ATTENTIVEMENT CE QUI SUIT AVANT D'ASSEMBLER CETTE UNITE IMPORTANT!! IMPORTANT!!

L'assemblage et la conception de cet appareil ont été conçus avec soin. Tous les sacs d'écrous et de boulons ont été emballés pour faciliter l'assemblage. Suivre les instructions d'assemblage à la lettre. Au moins une autre personne sera requise pour aider à installer cet appareil; deux personnes seraient préférables.

Assembler cet appareil en commençant par le début et poursuivre jusqu'à la fin. Les instructions d'assemblage sont rédigées afin de n'assembler qu'une seule section à la fois, avant de procéder à la suivante. Ne pas faire comme la plupart des gens, c'est-à-dire que lorsque plus rien ne va, ils lisent les instructions d'assemblage.

Lors de l'assemblage de cet appareil, s'il y manque des pièces, prière de nous aviser du numéro de la pièce ou de l'écrou, du boulon ou de la pièce qui manque, ainsi que de la couleur du modèle que vous avez acheté.

Des schémas aideront à l'assemblage de cette unité. Vérifier ces schémas pour l'emplacement exact des pièces.

Cet appareil devra être vérifié au moins une fois par semaine pour voir si les câbles sont usés, si les écrous et les boulons sont desserrés, si les pièces rembourrées sont desserrées et si les ensembles de pivot sont usés. **AVERTISSEMENT: LES CÂBLES MÉTALLIQUES S'USERONT!!**

La façon de vérifier les câbles métalliques est de glisser les doigts légèrement le long des câbles, si les câbles sont éfilochés, commander des câbles de remplacement à notre bureau.

Ceci est pour votre sécurité.

AVERTISSEMENT: L'USAGER EST RESPONSABLE DE SA PROPRE SÉCURITÉ!!

Si la boîte contenant les pièces du 401 Gym était scellée lors de l'achat et qu'il y manque des pièces, prière de nous en aviser par courrier et de nous faire parvenir une copie du reçu. Si la boîte était ouverte et qu'il y manque des pièces, le marchand en est responsable. Prière de nous indiquer le numéro de la pièce qui manque, elle sera remplacée par retour du courrier.

CANADA

YORK BARBELL CO LTD
1450 SOUTH SERVICE ROAD WEST
OAKVILLE, (TORONTO) ONTARIO,
CANADA L6L 5T7
TEL: (905) 827-6362
FAX: (905) 827-9593

AUSTRALIE

YORK BARBELL (AUST.) PTY.
LTD.
UNIT 1, LOT 2,
SWAFFHAM ROAD, MINTO,
N.S.W. 2566, AUSTRALIA
TEL: (02) 9603 8444
FAX: (02) 9603 8555

FRANCE

STRIALE FITNESS PARTNERS
RUE BENOIT FRACHON 17/21
ZONE INDUSTRIELLE B.
FRACHON
93000 BOBIGNY

ROYAUME-UNI

YORK BARBELL (U.K.) LTD
CHURCHILL WAY
DAVENTRY, NORTHANTS
ENGLAND NN11 4YB
TEL: (01327) 701800
FAX: (01327) 706704

OUTILS REQUIS POUR L'ASSEMBLAGE de l'appareil d'entraînement 401 Gym: a) gros tournevis b) 1 clé de 1/2" (13mm) c) 2 clés de 9/16" (14mm) d) 2 clés de 3/4" (19mm) e) 1 clé de 5/8" (16mm) f) 1 clé de 7/16" (11mm) g) marteau. **NE PAS UTILISER DE PINCES !!**

Cet appareil devrait être assemblé à la main seulement au début, afin de permettre un bon alignement.

1 pouce (") = 2.54cm environs



TO OUR VALUED CUSTOMER

You will notice that we have supplied you with 2 sets of weight decals. The reason for this is that this unit has a special multiplier feature when doing certain exercises.

The silver foil weight decals from 10lb/4.45kg to 80lb/36kg are the actual weight selection used when doing exercises #1, #2, #7, #15, #16, #17, #18, #19, #20, #21, #22, #23, #24.

These decals are placed on the right hand side of the weight stack. Starting with 10lb/4.45kg at the top and finishing with 80lb/36kg at the bottom.

The gold foil weight decals from 15lb/7kg to 120lb/54.5kg are the actual weight selection used when doing exercises #3, #4, #5, #6, #8, #9, #10, #11, #12, #13, #14.

These decals are to be placed on the left hand side of the weight stack. Starting with 15lb/7kg at the top and finishing with 120lb/54.5kg at the bottom.

À NOTRE CLIENT ESTIMÉ

Vous remarquerez que nous vous avons fourni 2 ensembles de décalcomanies de poids. En voici la raison: cette unité est dotée d'une caractéristique spéciale de multiplicateur lors de l'exécution de certains exercices.

Les décalcomanies de poids en papier d'aluminium argent allant de 10lb/4.5kg à 80lb/36kg représentent la sélection réelle des poids utilisée lors de l'exécution des exercices No. 1, 2, 7, 15, 16, 17, 18, 19, 20, 21, 22, 23, et 24.

Ces décalcomanies sont placées du côté droit de la pile de poids en commençant par 10lb/4.54kg au haut et en terminant par 80lb/36kg au bas.

Les décalcomanies de poids en papier d'aluminium doré allant de 15lb/7kg à 120lb/54.5kg représentent la sélection réelle des poids utilisée lors de l'exécution des exercices No. 3, 4, 5, 6, 8, 9, 10, 11, 12, 13, et 14.

Ces décalcomanies sont placées du côté gauche de la pile de poids en commençant par 15lb/7kg au haut et en terminant par 120lb/54.5kg au bas.

1

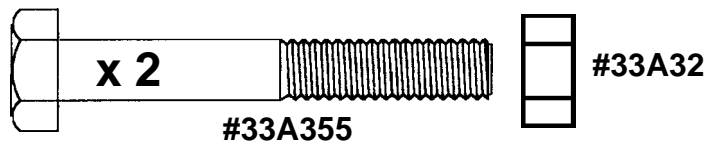
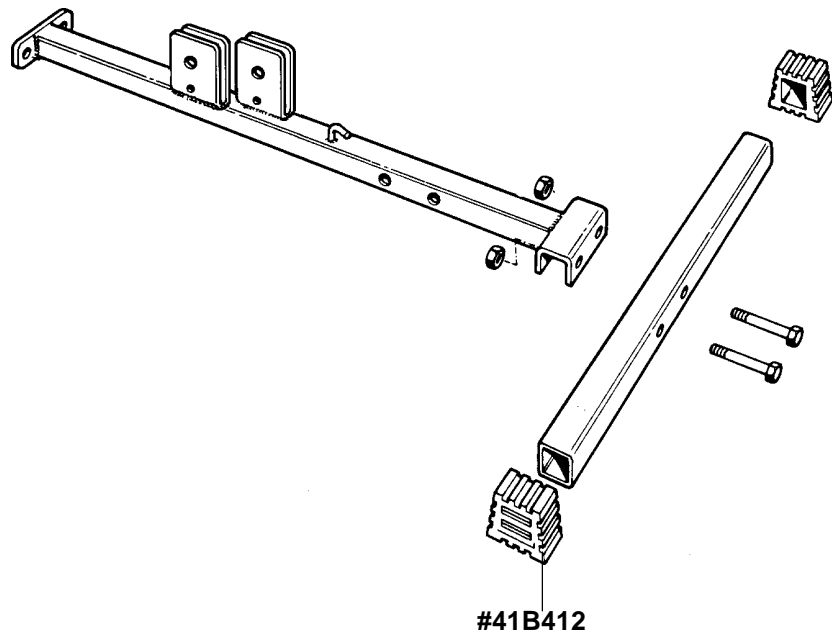

2

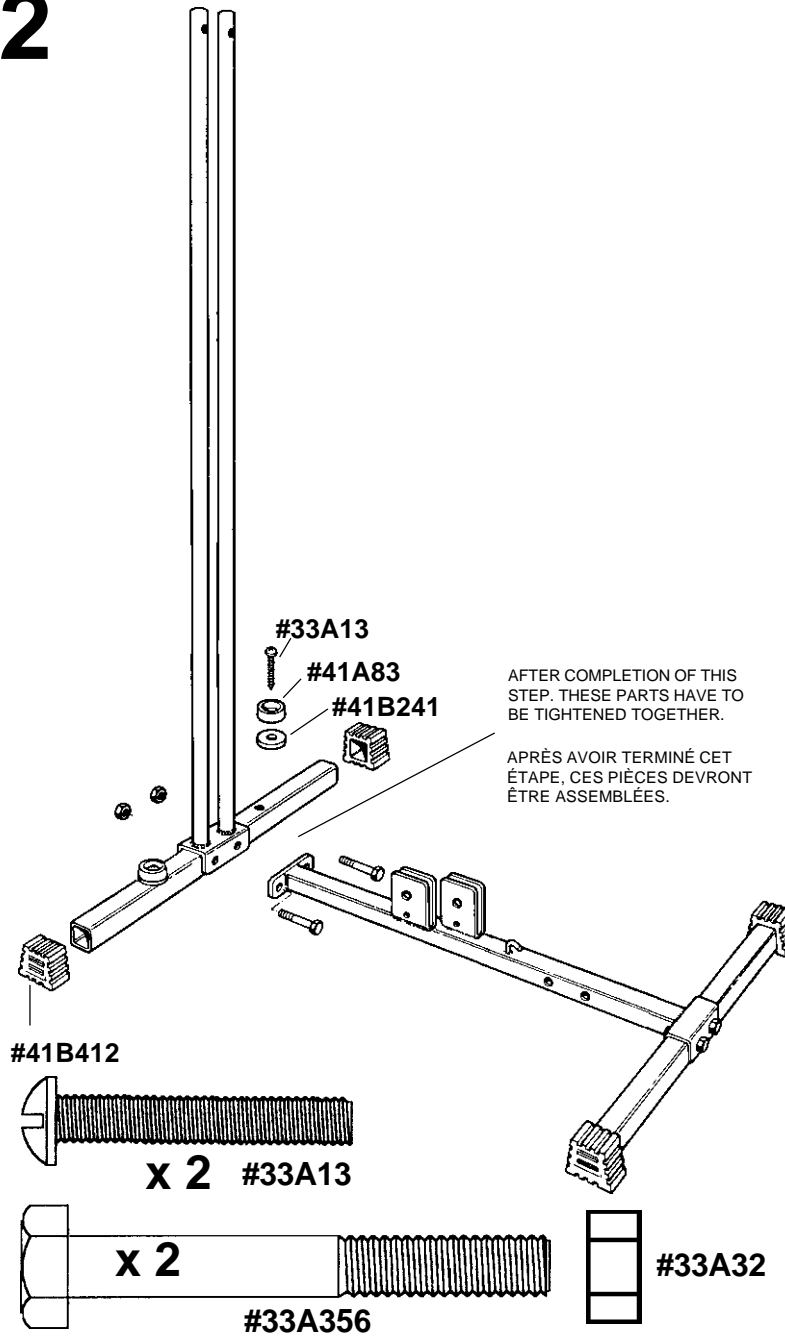

AFTER COMPLETION OF THIS STEP, THESE PARTS HAVE TO BE TIGHTENED TOGETHER.

APRÈS AVOIR TERMINÉ CET ÉTAPE, CES PIÈCES DEVRONT ÊTRE ASSEMBLÉES.

3

NOTE:
ALTERNATE THE SIDE
THE CAP IS ON FOR
THE WEIGHTS
ie. FIRST WEIGHT LEFT SIDE
SECOND WEIGHT RIGHT SIDE

NOTE:
ALTERNER L' EXTRÉMITÉ AYANT
UN OPERCULE POUR POSER
LES POIDS.
Par ex: OPERCULE À LA GAUCHE
POUR LE PREMIER POIDS,
OPERCULE À LA DROITE POUR
LE SECONDE POIDS.

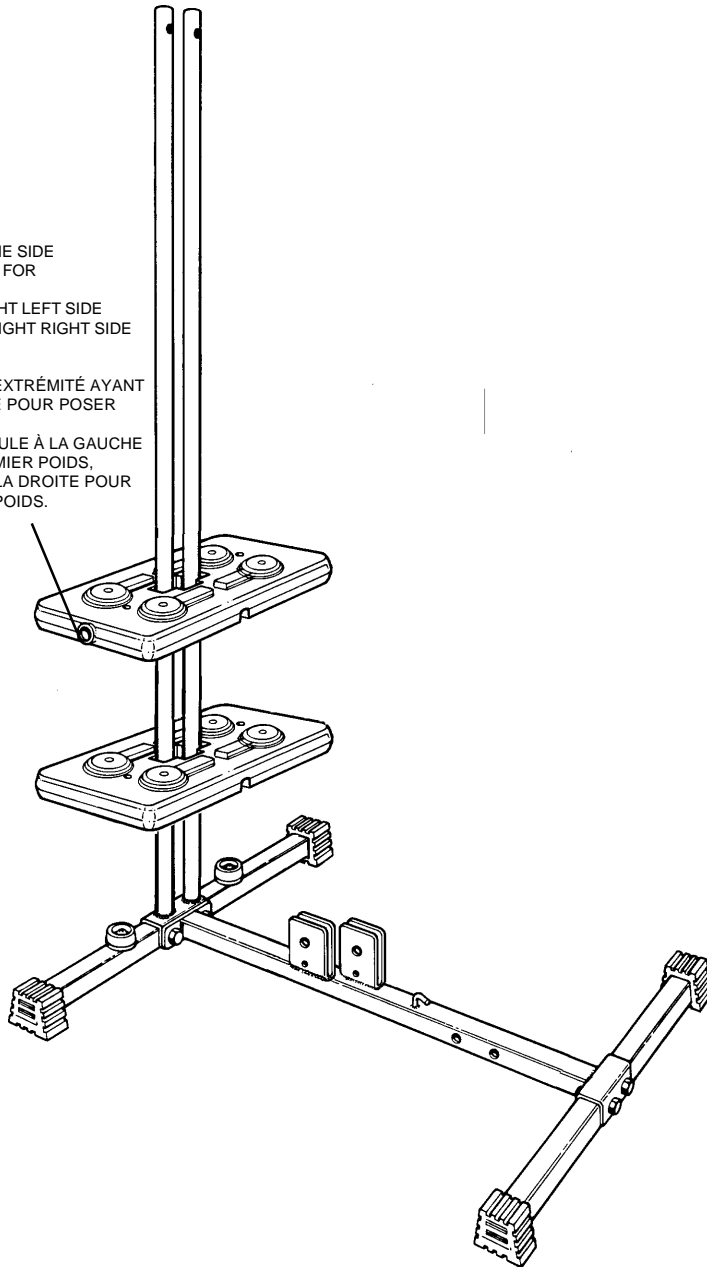

4

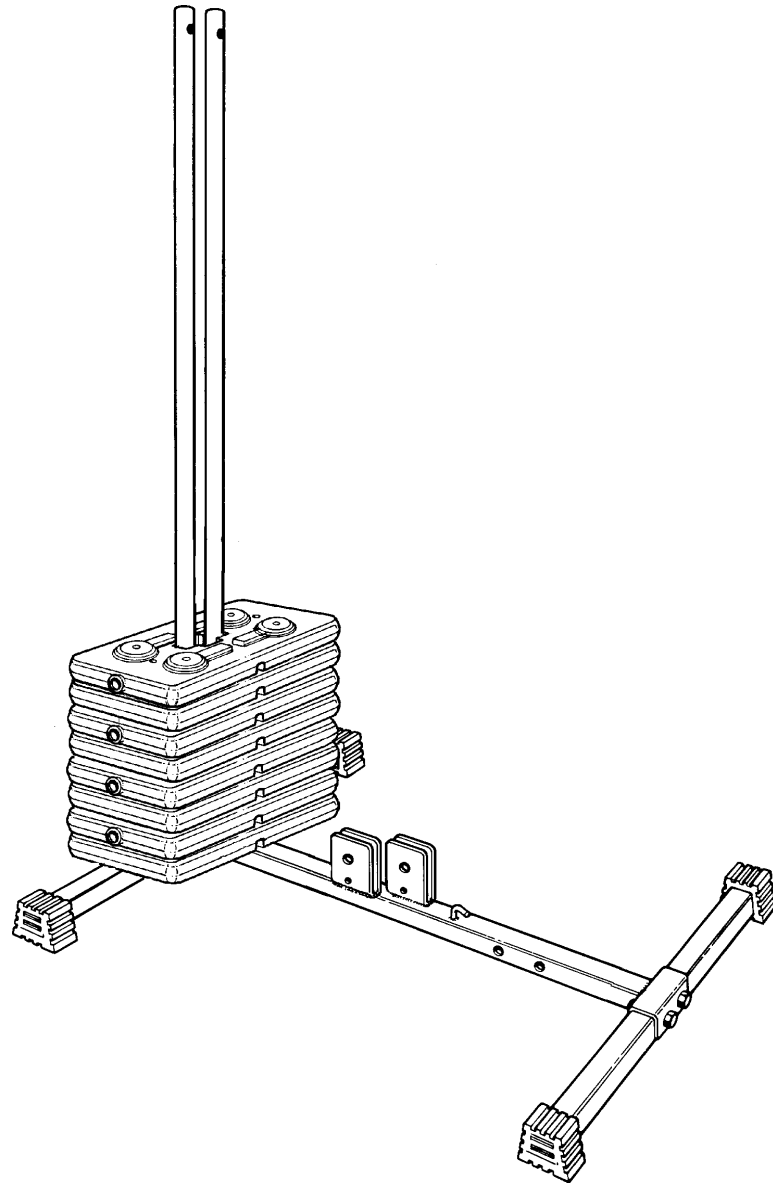

5

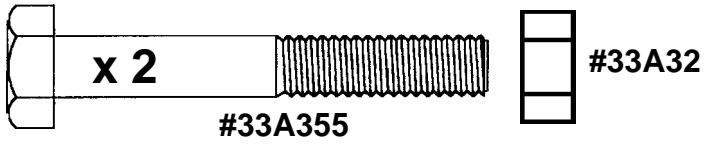
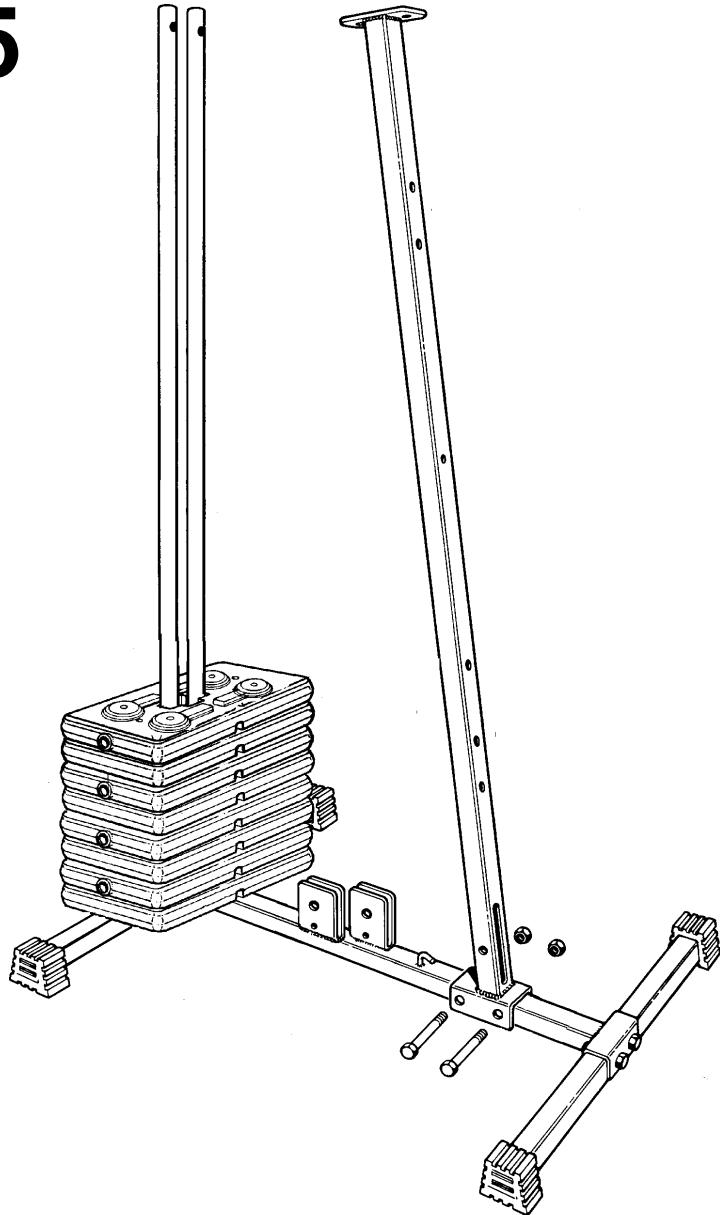

6

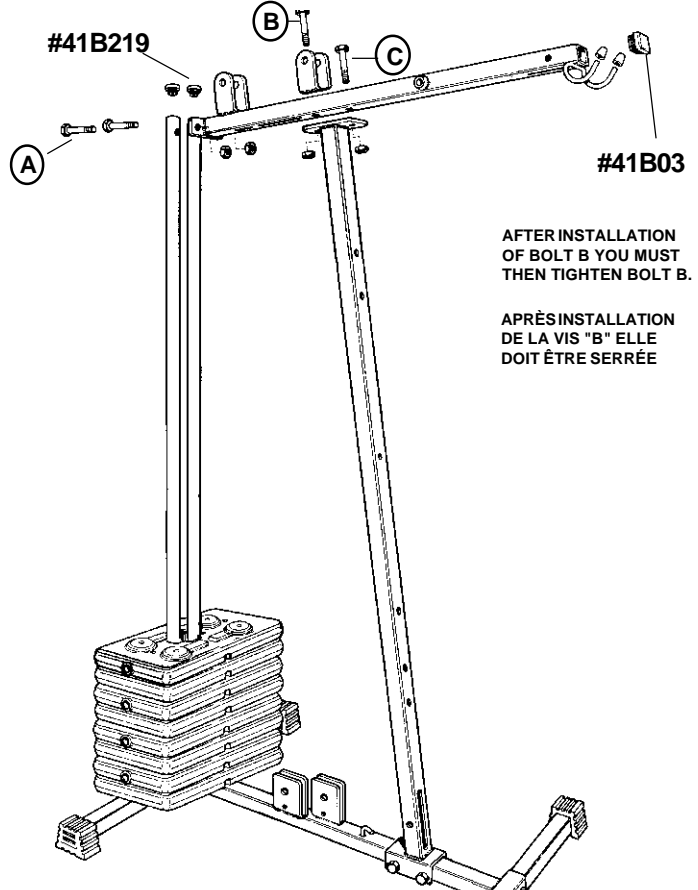

AFTER INSTALLATION
OF BOLT B YOU MUST
THEN TIGHTEN BOLT B.

APRÈS INSTALLATION
DE LA VIS "B" ELLE
DOIT ÊTRE SERRÉE

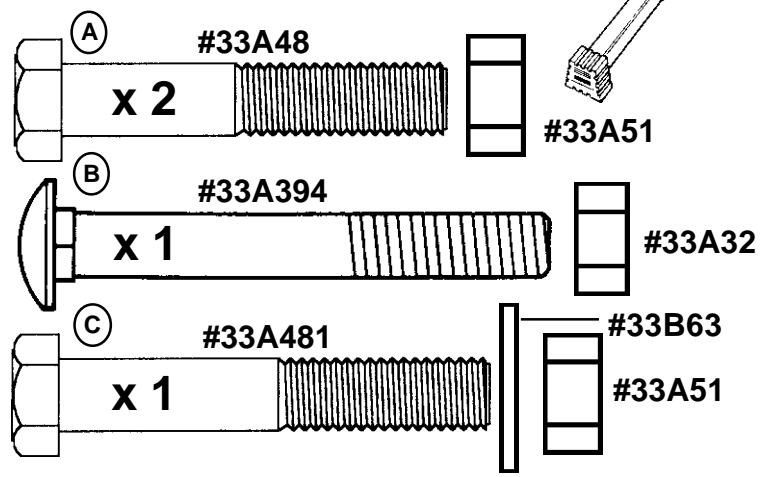

7

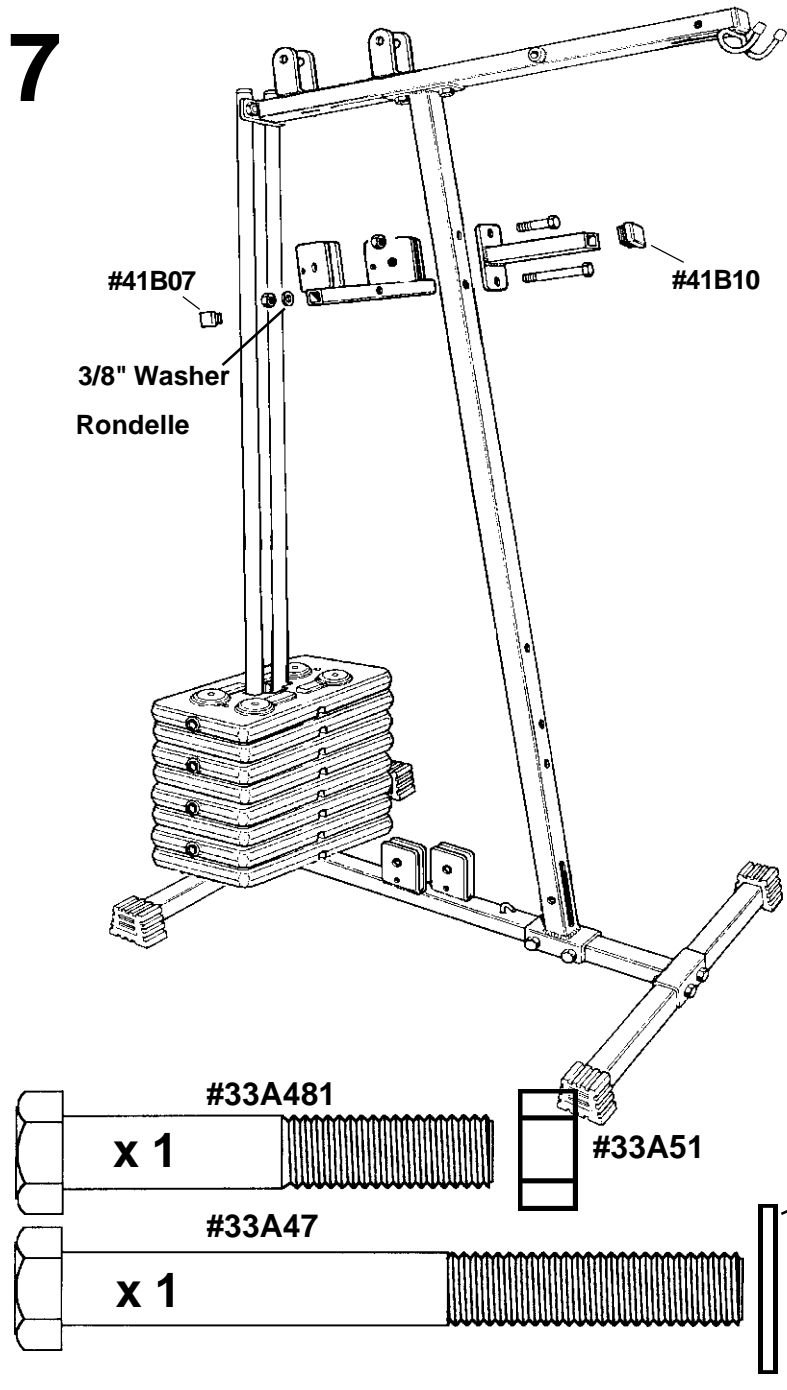

8

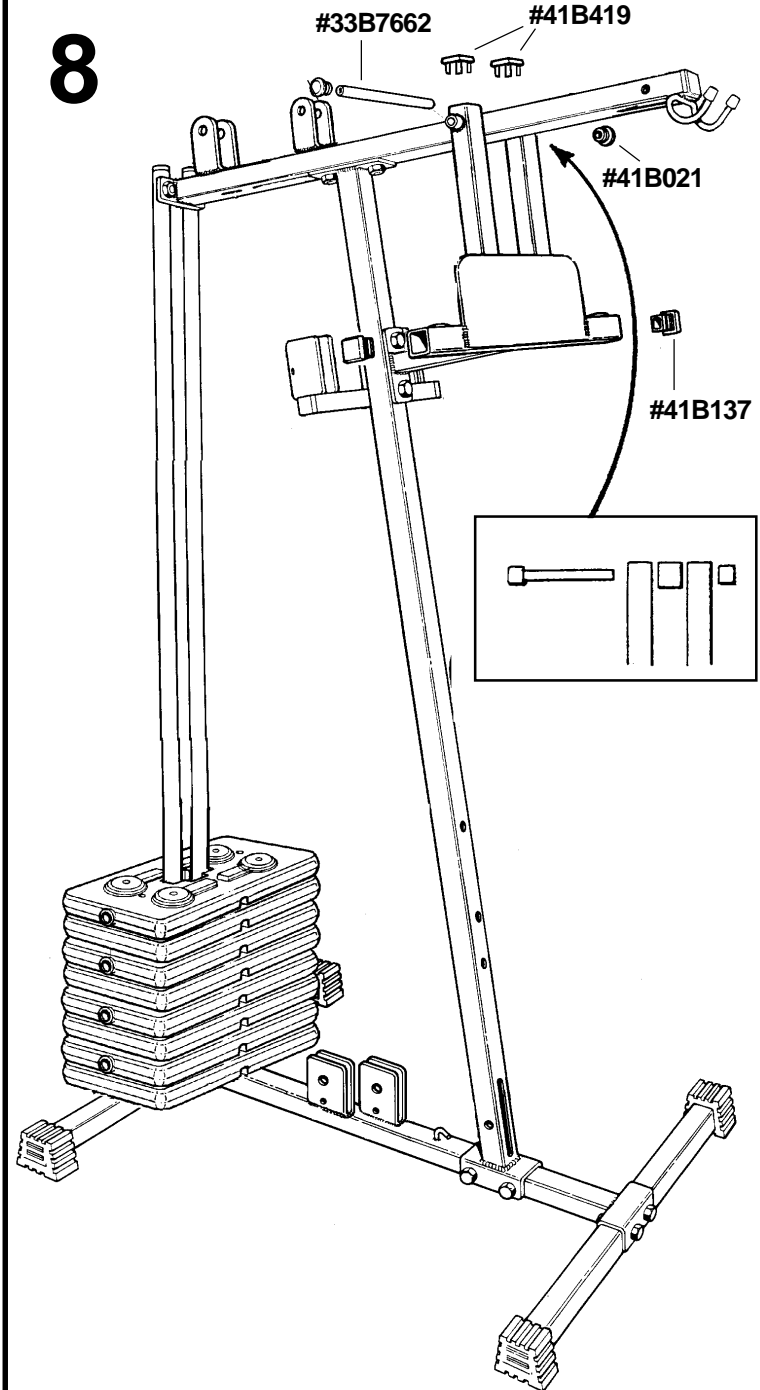

9

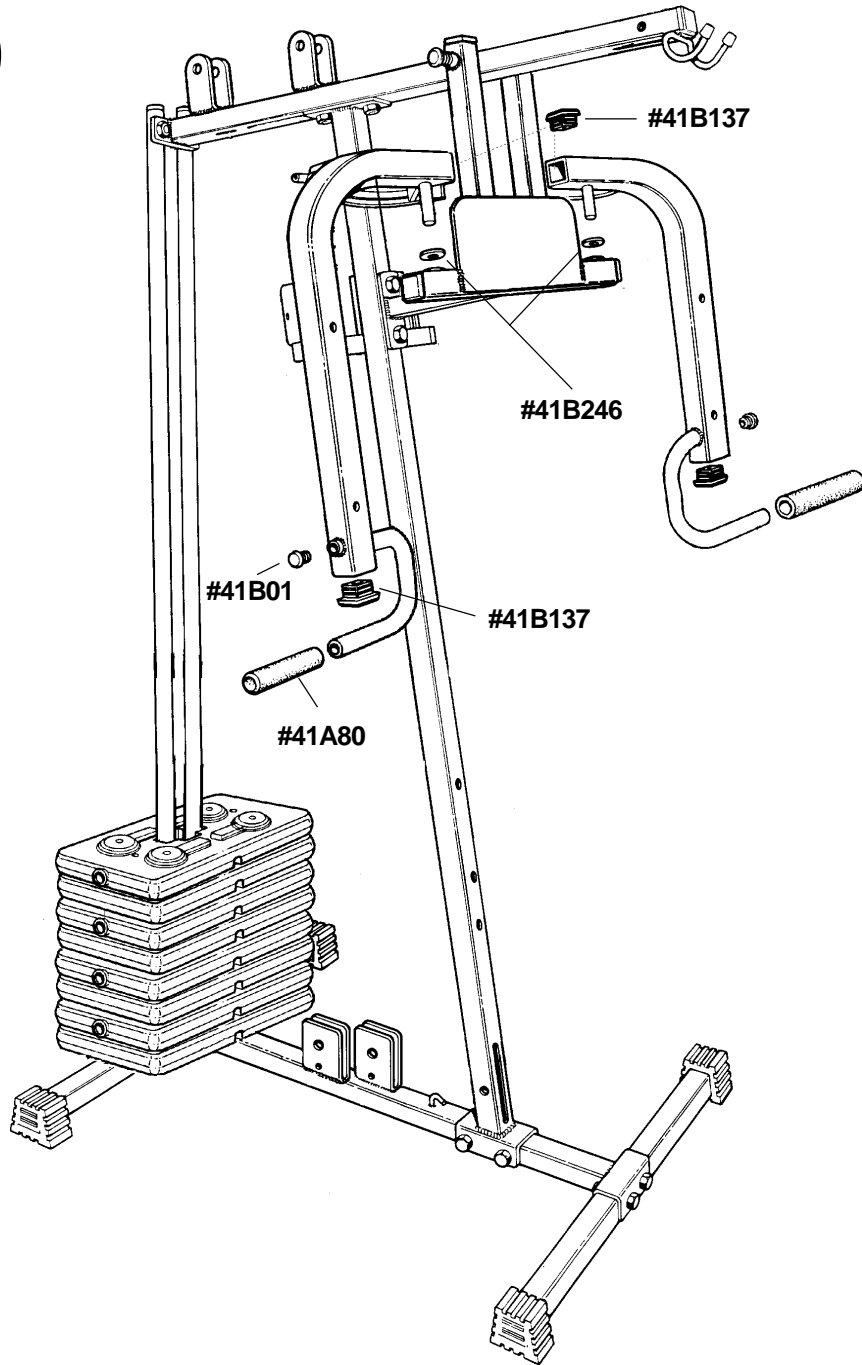

10

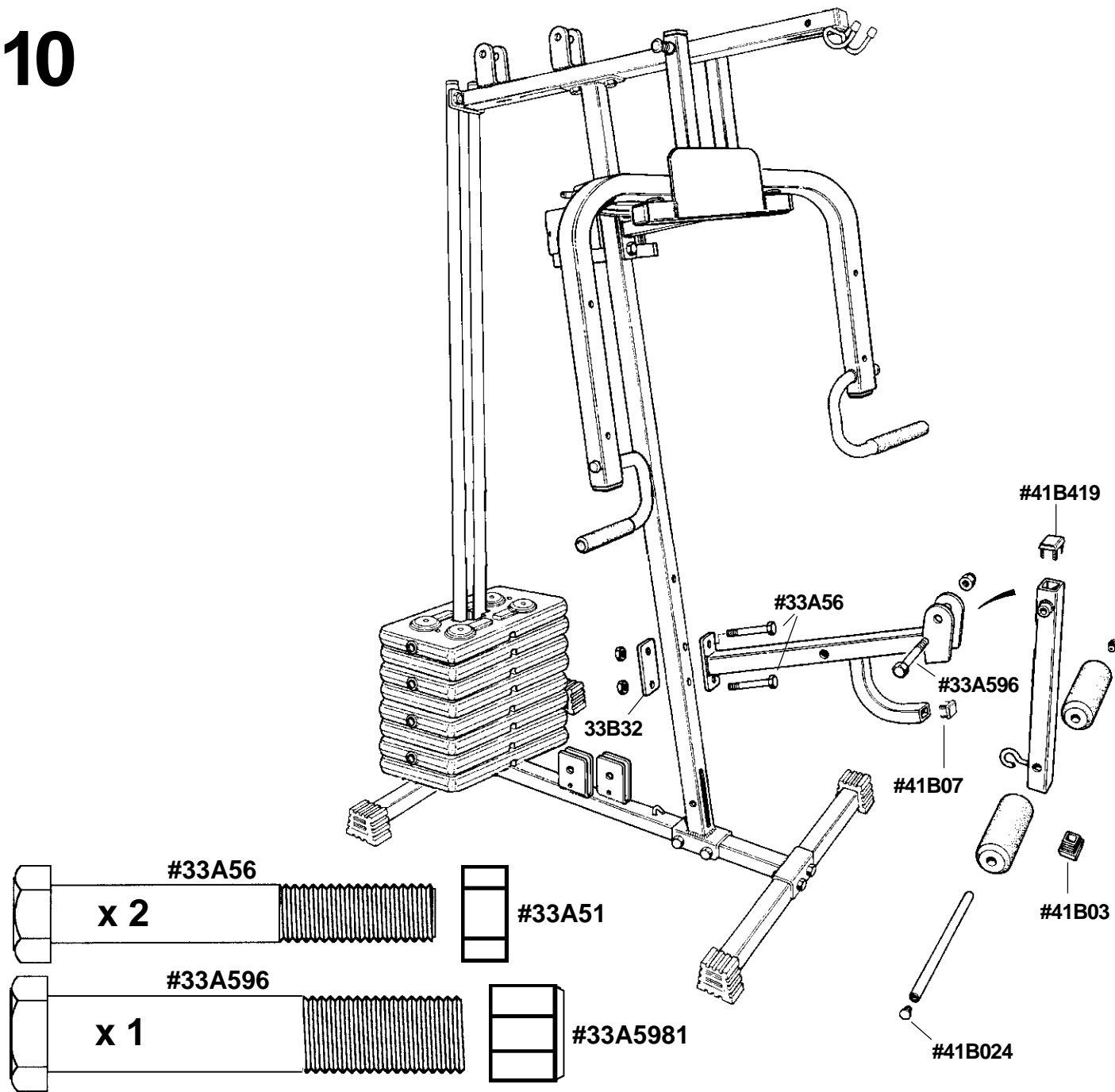

11

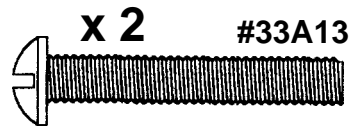
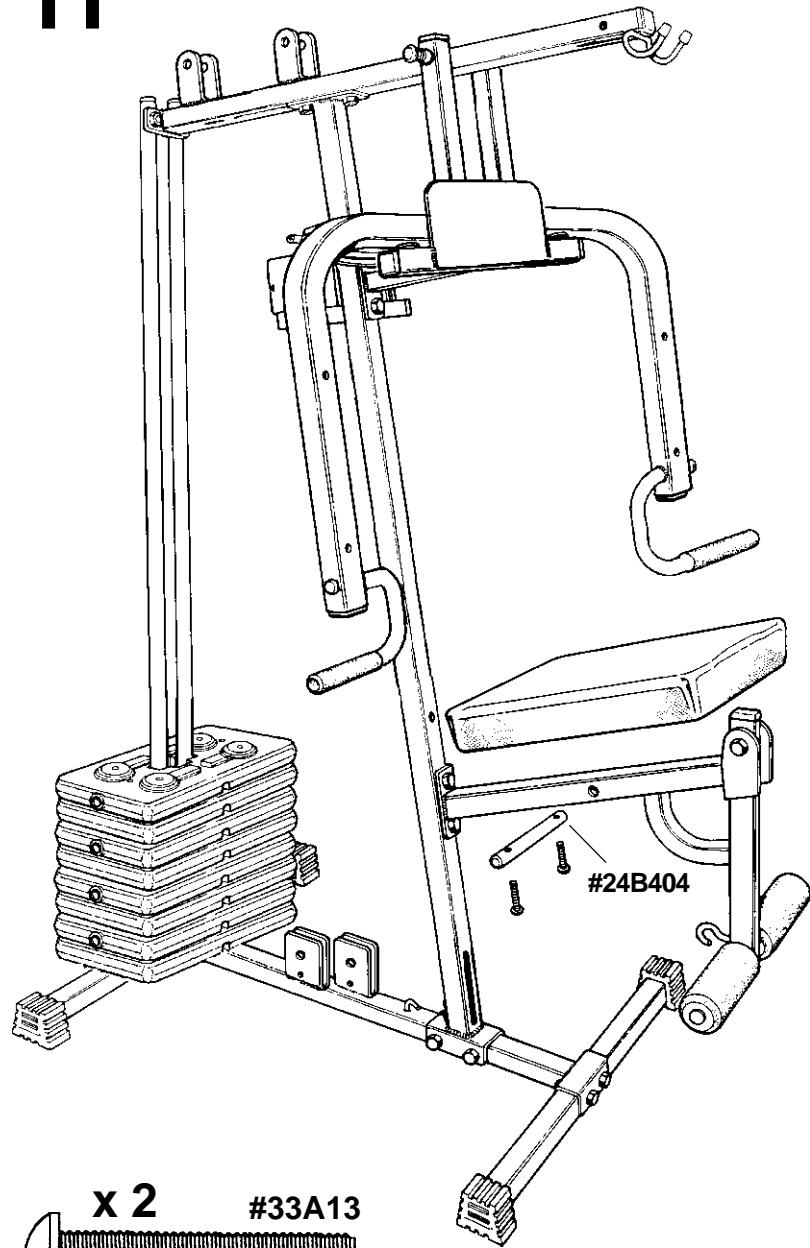

12

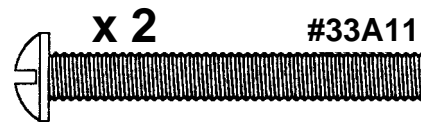
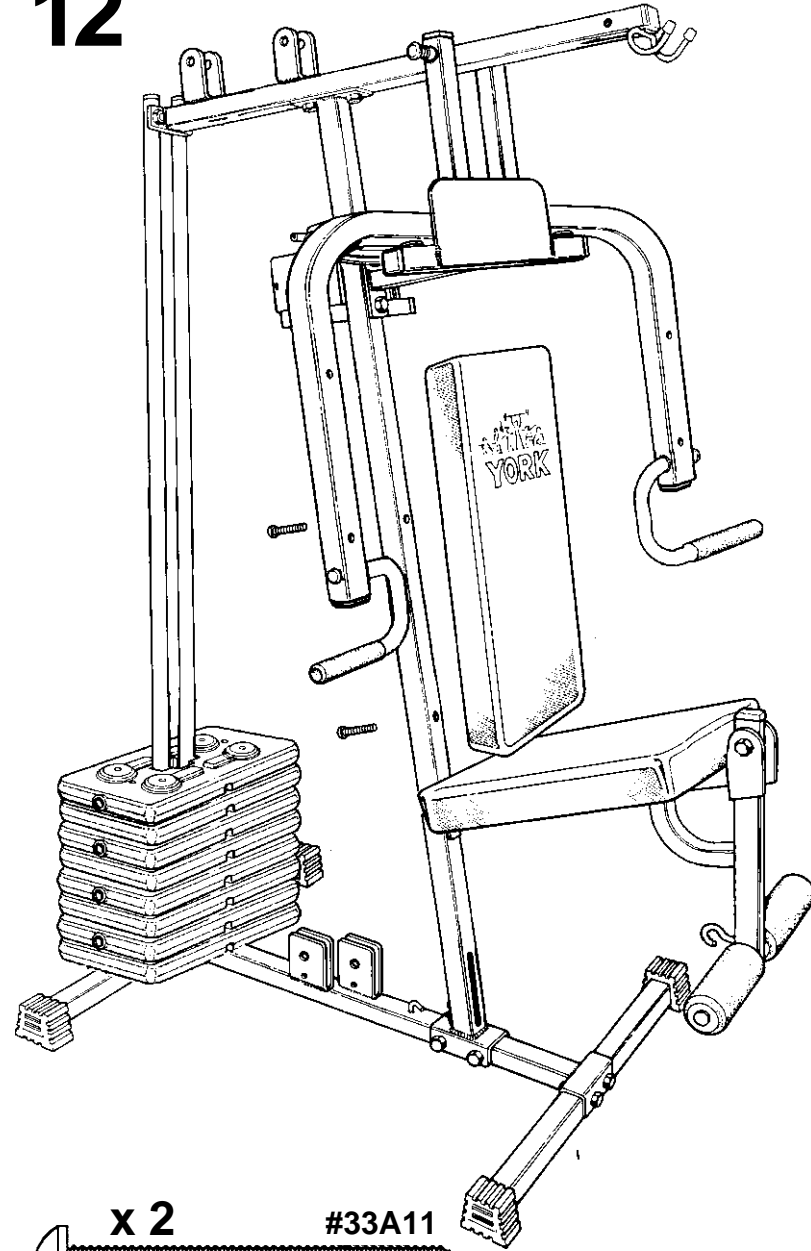

13

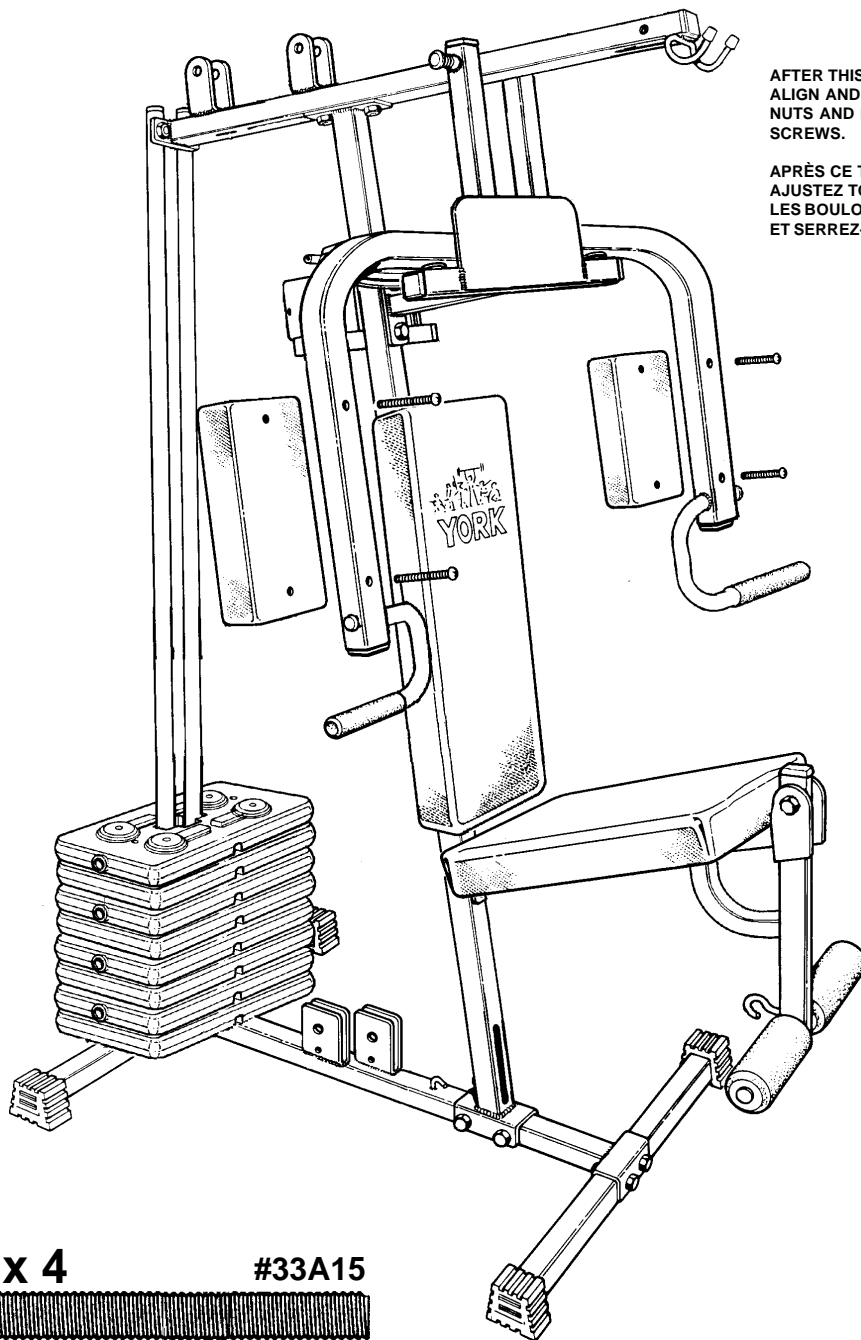

AFTER THIS STEP NOW
ALIGN AND TIGHTEN ALL
NUTS AND BOLTS AND
SCREWS.

APRÈS CE TRAVAIL,
AJUSTEZ TOUTES
LES BOULONS ET VIS
ET SERREZ-LES.

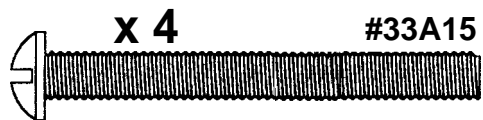

14

#82A001

#41A886

#82A001

#41B244

#33A48

x 2

#33A51

TOUT LE BLOC POULYE DOIT ETRE VISSÉE ENTRE LES PATTES.

THE PULLEY WHEEL ASSEMBLY MUST BE PLACED TOGETHER AS SHOWN IN DRAWING BEFORE INSTALLING IN BRACKET.

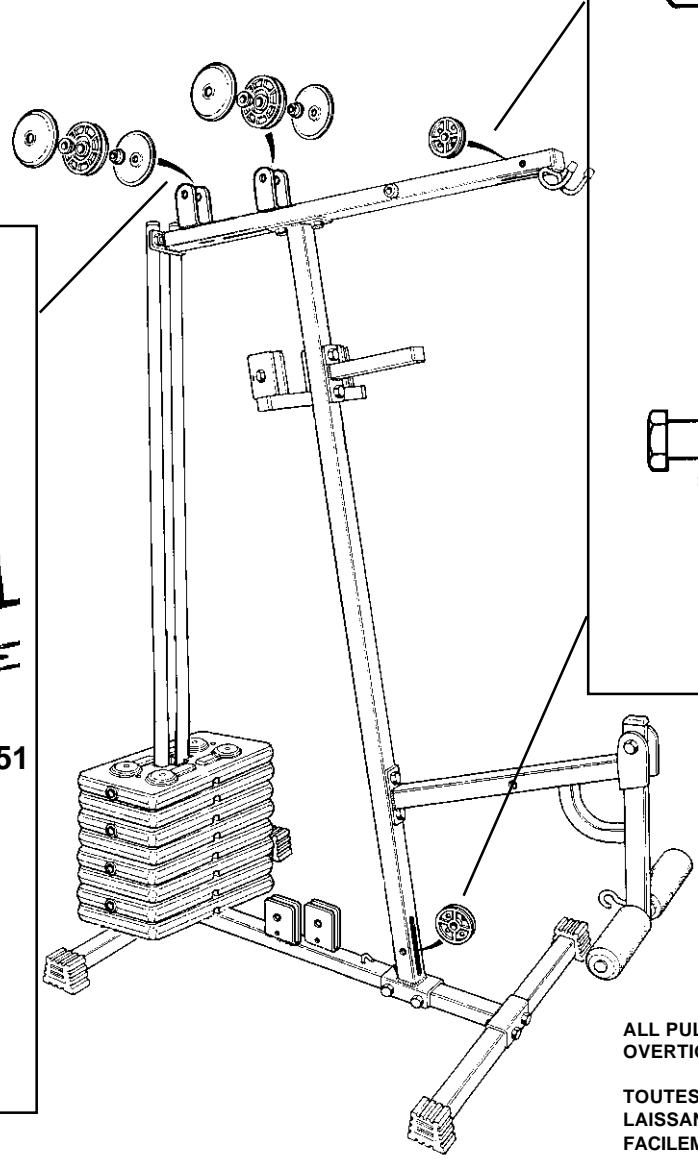

#33A46

#33A32

#41A890

#41A82

#41A890

#41B244

#33A46

#33A32

ALL PULLEY WHEELS SHOULD BE TIGHTENED. BUT DO NOT OVERTIGHTEN AS PULLEY WHEELS SHOULD STILL MOVE FREELY.

TOUTES LES ROUES DE POULIE DOIVANT ÊTRE SERRÉES EN LAISSANT SUFFISAMMENT D'ÉSPACE POUR LES FAIRE TOURNER FACILEMENT.

15

ALL PULLEY WHEELS SHOULD BE TIGHTENED, BUT DO NOT OVERTIGHTEN AS PULLEY WHEELS SHOULD STILL MOVE FREELY.

TOUTES LES ROUES DE POULIE DOIVANT ÊTRE SERRÉES EN LAISSANT SUFFISAMMENT D'ESPACE POUR LES FAIRE TOURNER FACILEMENT.

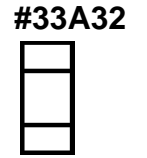
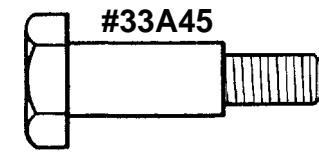
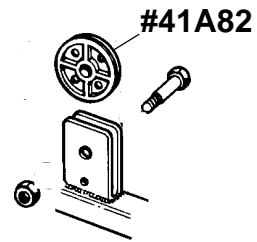
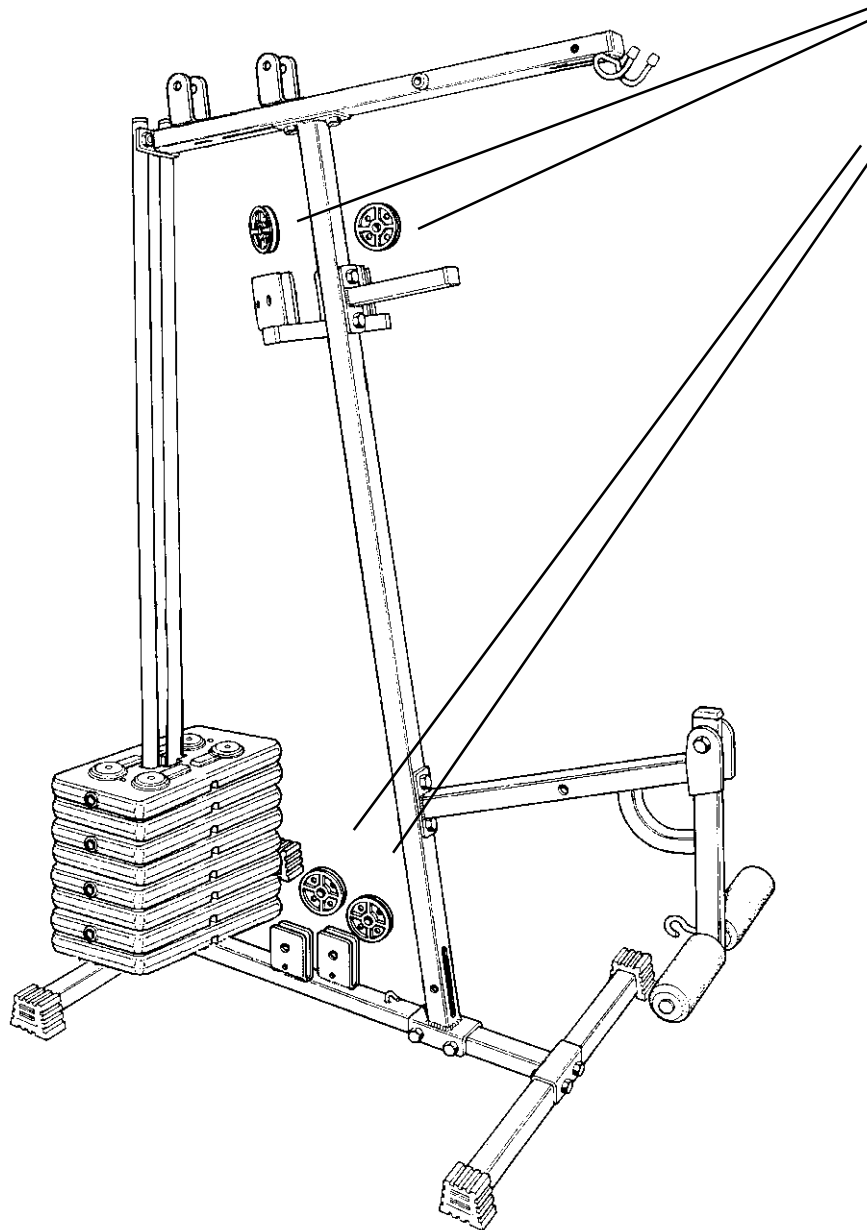

x 4

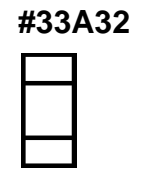
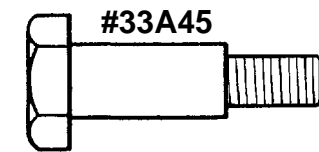
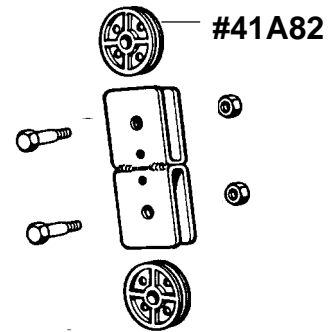

x 2

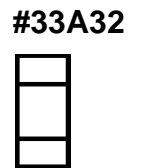
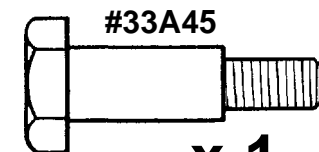
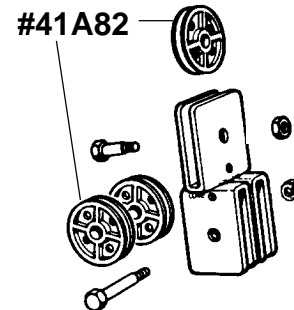

x 1

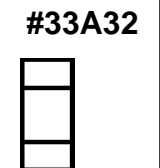
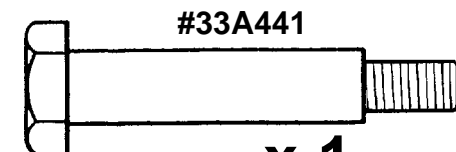

x 1

16

CABLES CÂBLES

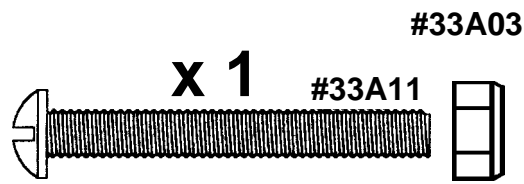
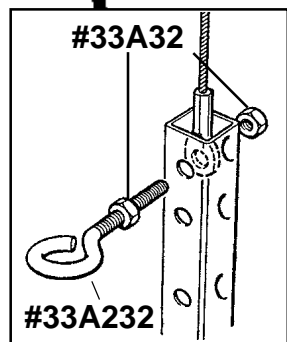
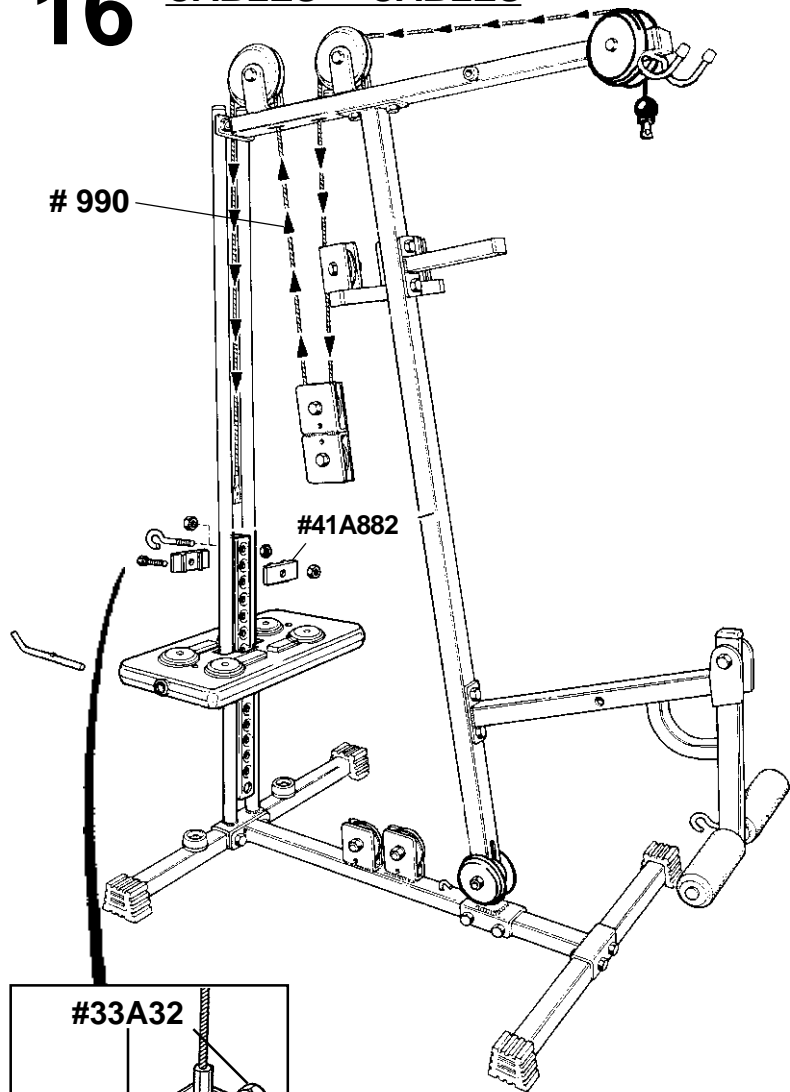

17

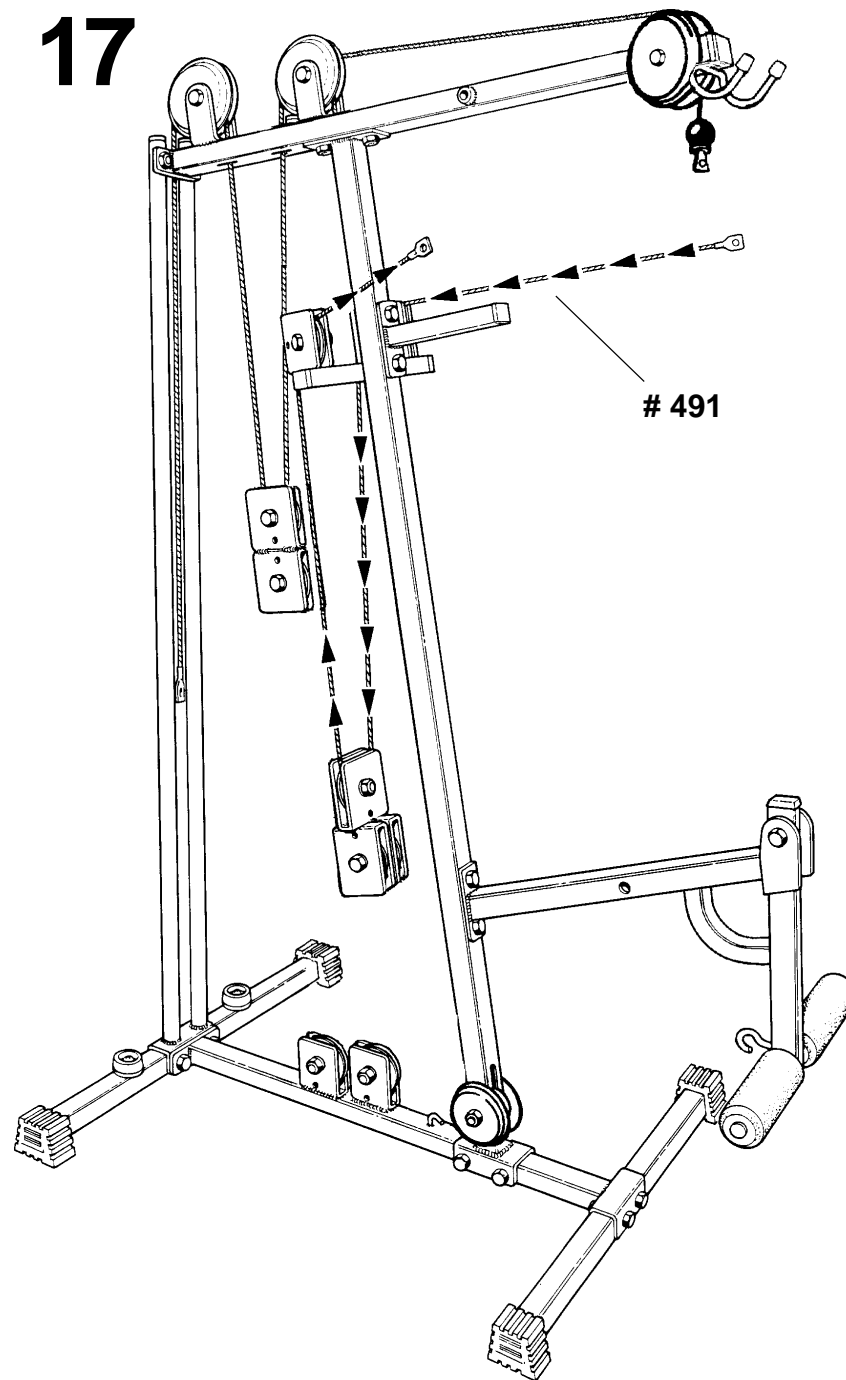

18

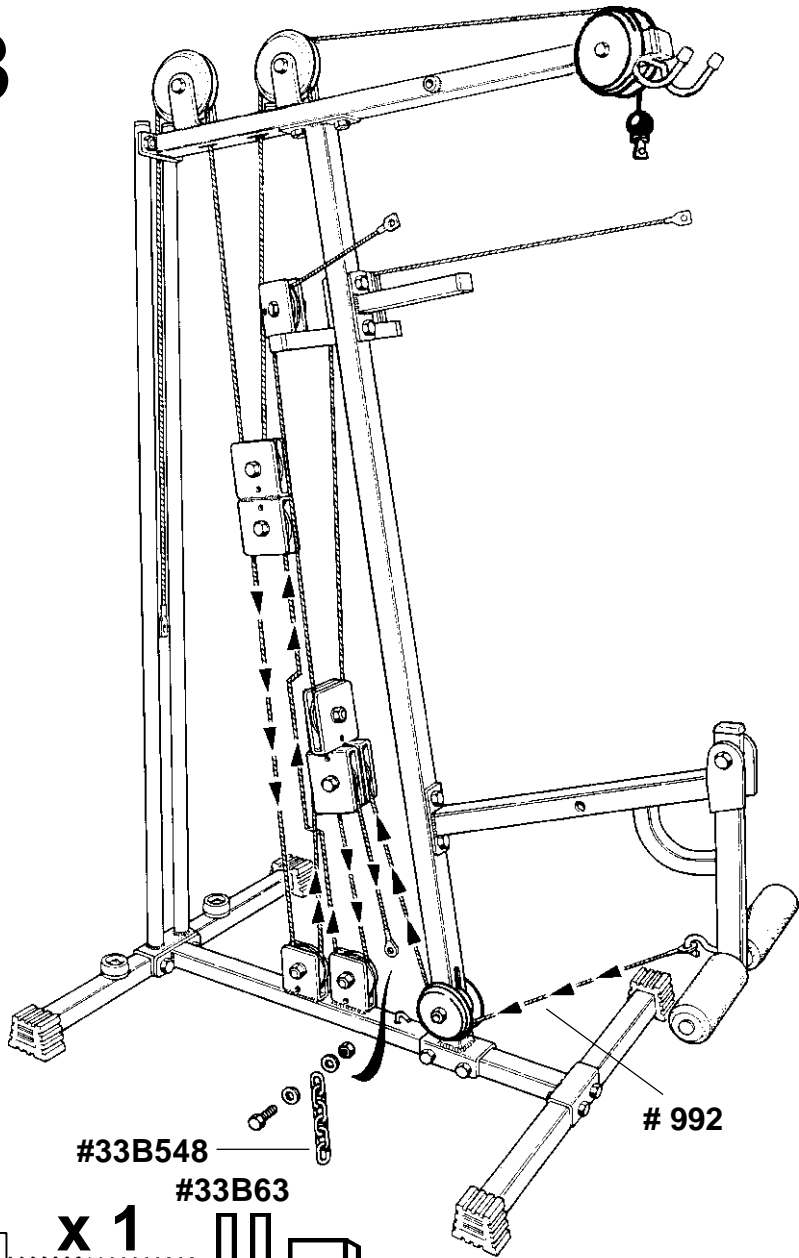

#33B548

#33B63

992

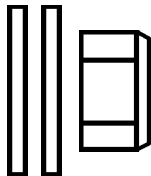
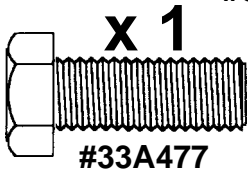

#33A53

19

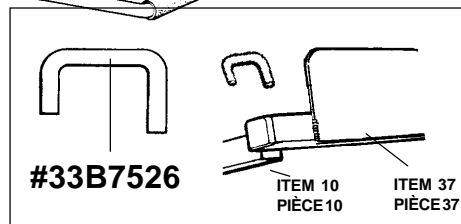
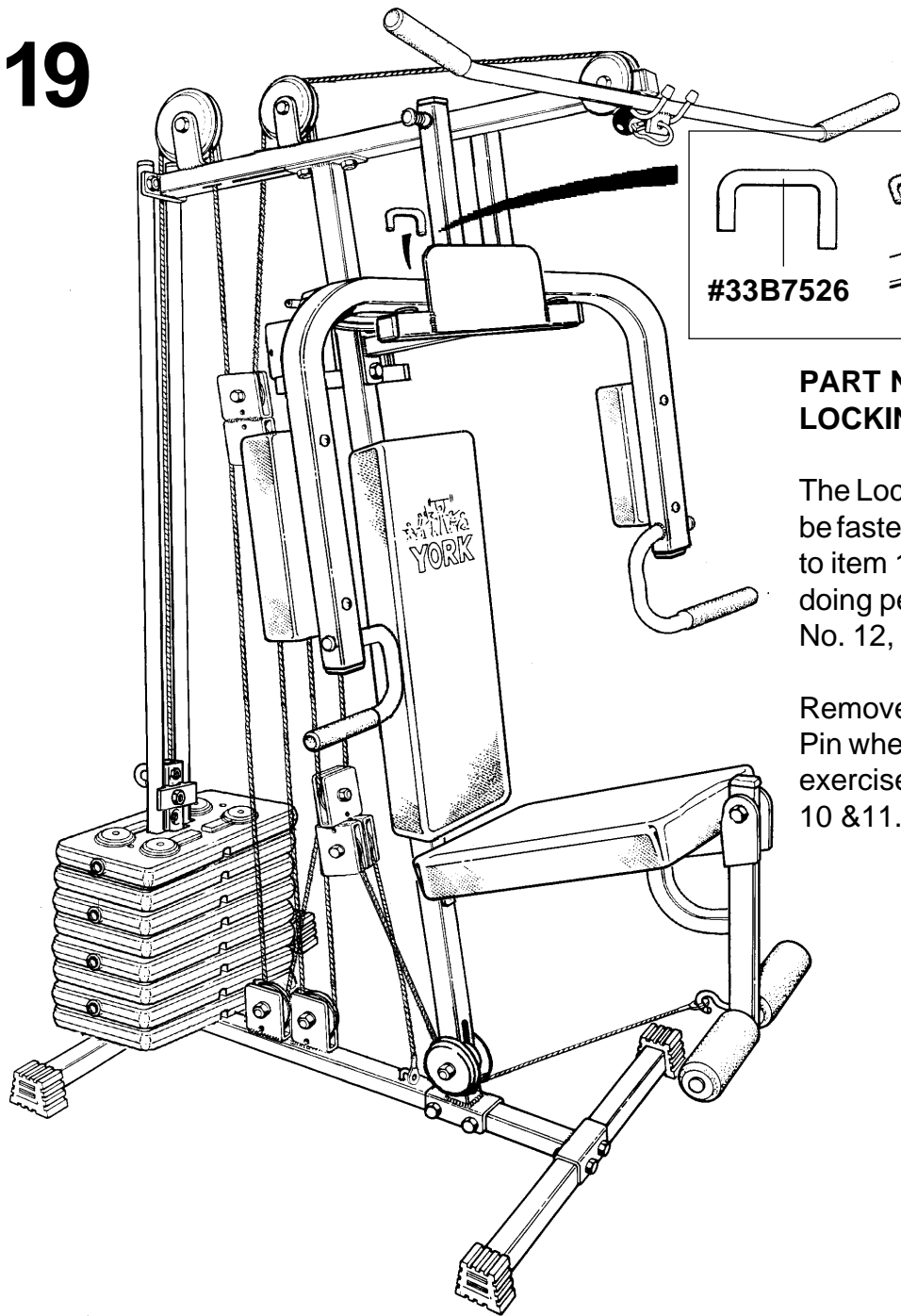

**PART No. 33B7526
LOCKING PIN**

The Locking Pin should be fastened securely to item 10 & 37 when doing pec exercises, No. 12, 13 & 14.

Remove the Locking Pin when doing press exercises, No. 3, 4, 8, 9, 10 & 11.

**PIÈCE No. 33B7526
GOUPILLE DE RÉGLAGE**

Le goupille de verrouillage doit être fixée fermement aux pièces No. 10 et 37 lorsque les exercices pour pectoraux No. 12, 13 et 14 seront effectués.

Retirer la goupille de verrouillage pour effectuer les développés couchés No. 3, 4, 8, 9, 10 et 11.

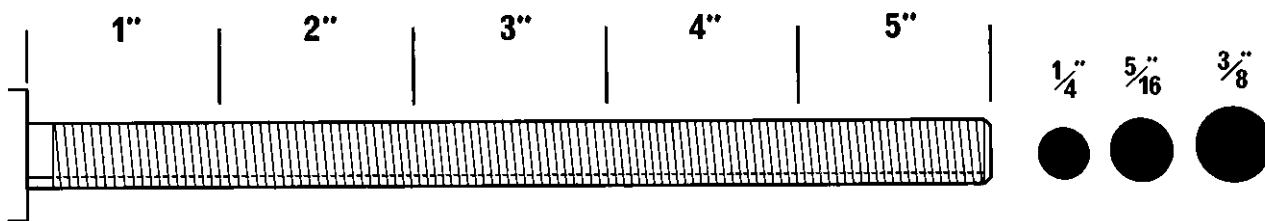

401 GYM

401 BLACK V.P. HOME GYM #5070 - UK

BAG No. 247 401 PULLEY HARDWARE #32C197		
PART No.		QTY.
33A32	5/16" HEX NUT	10
33A441	3/8 - 1 1/2" SHOULDER BOLTS	1
33A45	3/8 - 13/16" SHOULDER BOLTS	7
33A48	3/8 - 16 x 2" H.H. BOLT	2
33A51	3/8 - 16 HEX NUT	2
33A46	3/8 - 2" SHOULDER BOLT	2
41A890	401 DELRON PULLEY SPACER	4

BAG No. 250 401 HARDWARE #32C200		
PART No.		QTY.
24B404	PART #B7505 - 5/8" x 8" TUBE	1
33A13	1/4 - 20 x 1 1/2" - RHSMS	4
33A15	1/4 - 20 x 2 1/4" - RHSMS	4
33A11	1/4 - 20 x 2" RHSMS	2
33A47	3/8 - 16 x 3 1/2" H.H. BOLT	1
33A63	3/8" SAE WASHER	2
33A48	3/8 - 16 x 2" H.H. BOLT	2
33A481	3/8 - 16 x 2 1/4" H.H. BOLT	2
33A51	3/8 - 16 HEX NUT	7
33A56	3/8 - 16 x 2 1/2" H.H. BOLT	2
33A596	1/2 - 13 x 2 3/4" H.H. BOLT	1
33A5981	1/2 - 13 NYLON LOCK NUT	1
33B32	2001 PART #B1234 - 4 1/2" BRACKET	1
33B7526	1501 PART #1392 LOCKING PIN	1
33B7661	401 PART #B451 PULLEY BRACKET	1
33B7662	401 PART #B460 1/2" x 6 1/2" ROD	1
41B021	1/2" RD. EXT BLACK CAP	2
33A355	5/16 - 18 x 2 1/4" HH BOLT	4
33A356	5/16 - 18 x 2 1/2" HH BOLT	2
33A394	5/16 - 18 x 2 1/2" CARRIAGE BOLT	1
33A32	5/16 - 18 HEX NUT	7

BAG No. 249 401 ASSEMBLY / DECALS #32C199		
PART No.		QTY.
01A491	DECALS 10 TO 120 LBS (901- 3001)	1
01A492	DECALS 15 TO 180 LBS GOLD - 901	1
01A684	401/ 901 WALL CHART	1
01A687	401 ASSEMBLY INSTRUCTIONS	1
01A878	401 VP/ PEC DECAL	1
01A879	401 L/C DECAL	1

401 YORK Fitness PARTS LIST



401 GYM

401 GYMNASSE DE MAISON V.P. NOIR #5070 - UK

SAC No. 247		#32C197
PIECE No.		QTÉ.
33A32	ÉCROUS HEXAGONAL DE 5/16"	10
33A441	BOULONS MÉCANIQUES DE 3/8 - 1 1/2	1
33A45	BOULONS MÉCANIQUES DE 3/8 - 13/16"	7
33A48	16 BOULONS HEX. DE 3/8 x 2"	2
33A51	16 ÉCROUS HEXAGONAL DE 3/8"	2
33A46	BOULONS MÉCANIQUES DE 3/8" - 2"	2
41A890	401 RONDELLE D'ESPACEMENT DE POULIE	4

SAC No. 249		# 32C199
PIECE No.		QTÉ.
01A491	DÉCALCOMANIE 10 À 120LBS	1
01A492	DÉCALCOMANIE 15 À 180LBS	1
01A684	TABLEAUX MURAUX 401	1
01A687	INSTRUCTIONS D'ASSEMBLAGE 401	1
01A878	DÉCALCOMANIE PECTORALE 401	1
01A879	DÉCALCOMANIE DESOULÈVEMENT DES JAMBES 401	1

SAC No. 250		# 32C200
PIÈCE No.		QTÉ.
24B404	No. B7505 TUBE DE 5/8 x 8"	1
33A13	20 VIS À TOLE DE 1/4 x 1 1/2"	4
33A15	20 VIS À TOLE DE 1/4 x 2 1/4"	4
33A11	20 VIS À TOLE DE 1/4" x 2"	2
33A47	16 BOULONS HEX. DE 3/8 x 3 1/2"	1
33A63	RONDELLES SAE DE 3/8"	2
33A48	16 BOULONS HEX. DE 3/8 x 2"	2
33A481	16 BOULONS HEX. DE 3/8 x 2 1/4"	2
33A51	16 ÉCROUS HEXAGONAUX DE 3/8"	7
33A56	16 BOULONS HEX. DE 3/8 x 2 1/2"	2
33A596	13 BOULONS HEX. DE 1/2 x 2 3/4"	1
33A5981	13 ÉCROUS DE BLOCAGE DE 1/2"	1
33B32	2001 ARTICLE No. B1234	1
33B7526	No.1392 GOUPILLE DEVERROUILLAGE 1501	1
33B7661	401 ARTICLE No. B451	1
33B7662	No. B460 - 1/2" x 6 1/2" ROD	1
41B021	OPERCULE ROND EXTÉRIEUR DE 1/2"	2
33A355	18 BOULONS HEX. DE 5/16 x 2 1/4"	4
33A356	18 BOULONS HEX. DE 5/16 x 2 1/2"	2
33A394	18 BOULONS VOITURE DE 5/16 x 2 1/2"	1
33A32	18 ÉCROUS HEXAGONAUX DE 5/16"	7

401 YORK FITNESS
 PARTS LIST



401 GYM

BAG No.248 #32C198
SAC No.248

ITEM ARTICLE	PART No. PIÈCENo.	QTY QTÉ
19	41A80	4
20	41A83	2
21	41B01	2
22	41B024	2
23	41B03	2
24	41B07	3
25	41B137	6
26	41B219	2
27	41B241	2
28	41B412	4
29	41B419	3
30	41B10	1
50	41B246	2

**PARTS LIST(A)
LISTE DES PIÈCES (A)**

ITEM ARTICLE	PART No. PIÈCENo.	QTY QTÉ
1	B401	1
2	B404R	1
3	B403F	1
4	B405-UK	1
5	B407	1
6	B410	1
7	B411	1
8	B408	1
9	B909	1
10	B406	1
11	B415	1
12	B916	1
13	B917	1
14	B412	1
15	B2411	1
16	27A59	2
17	30B474	1
18	50E40	8

**BAG No.246 #32C196
SAC No.246**

ITEM ARTICLE	PART No. PIÈCE No.	QTY QTÉ
31	41A82	11
32	41A886	2
33	41B244	8
34	82A001	4

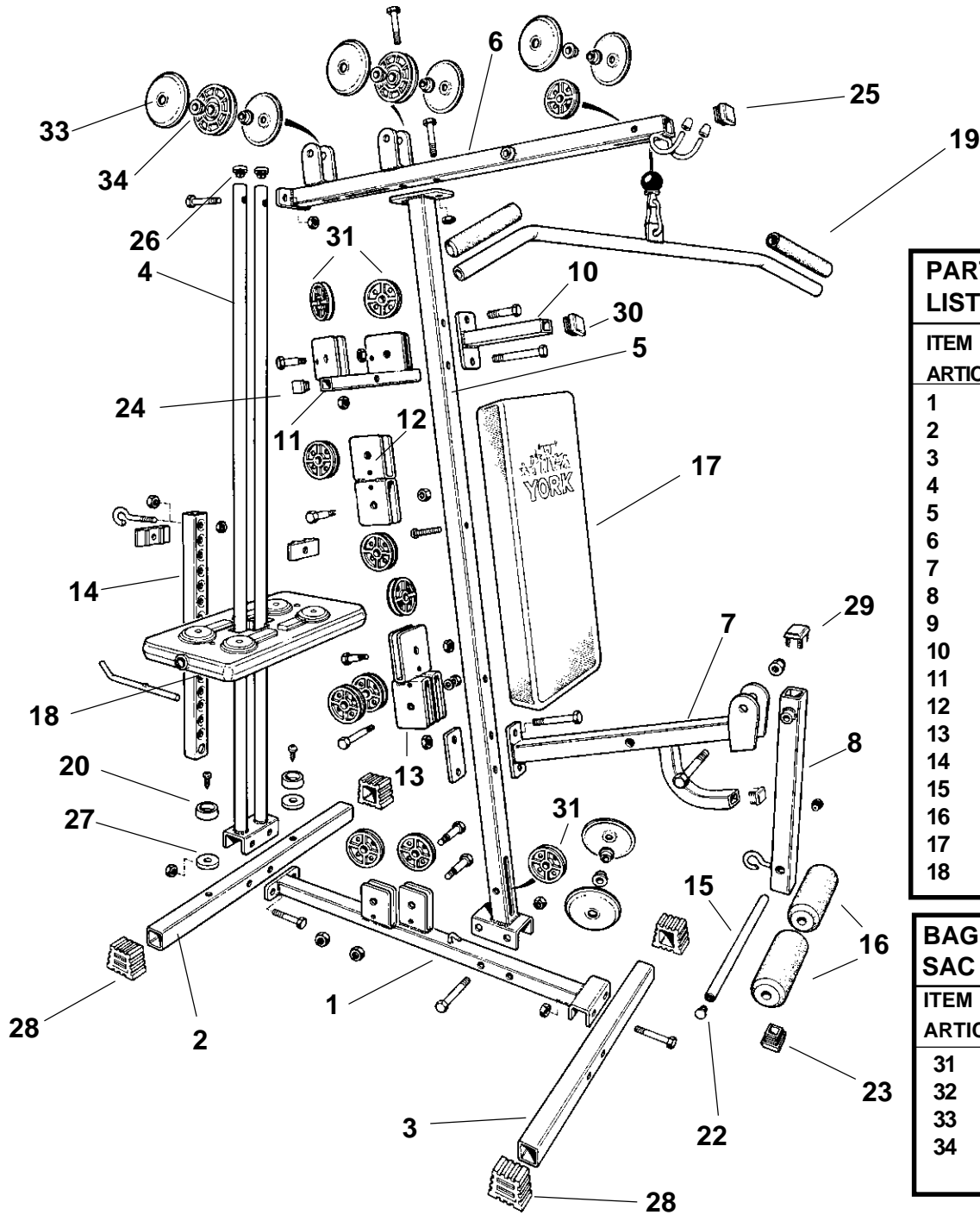

401 YORK
fitness
 PARTS LIST

401 GYM

401 YORK *fitness* PARTS LIST

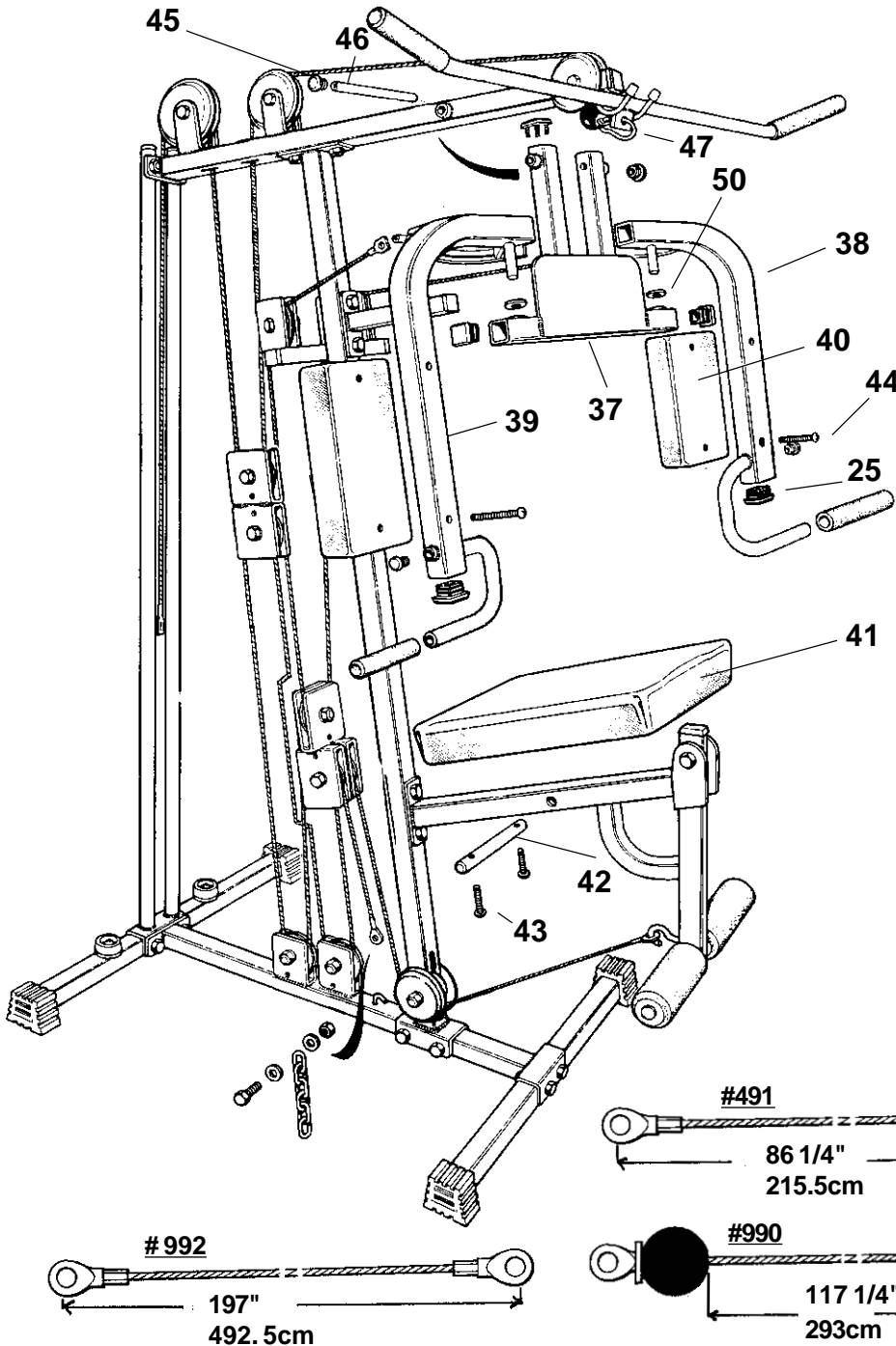

BAG No. 245 # 32C195

PART No.		QTY.
33A03	1/4 - 20 LOCKNUTS	1
33A11	1/4 - 20 x 2" RHSMS	1
33A232	5/16 - 18 x 3 1/2" EYE BOLT	1
33A32	5/16 - 18 HEX NUTS	2
33A477	3/8 - 16 x 1" H.H. BOLT	1
33A489	3001 5/16" SAFETY CLIP	1
33A53	3/8 - 16 LOCK NUT	1
33A7881	901-#992 WIRE ROPE 197"	1
33A7883	901-#990 WIRE ROPE 117 1/4"	1
33A7898	401-#491 WIRE ROPE 86 1/4"	1
33B02	2001 PART #1250	1
33B63	3/8" - SAE WASHER	2
33B548	5 LINKCHAIN	1
41A882	2600 PLASTIC GUIDE	2

PARTS LIST (B)
LISTE DE PIÈCE (B)

ITEM ARTICLE	PART No. PIÈCE No.	QTY QTÉ
37	B414	1
38	B418L-UK	1
39	B418R-UK	1
40	30B473	2
41	30B472	1
42	B7505	1
43	33A145	2
44	33A15	4
45	41B021	2
46	33B762	1
47	33A490	1

SAC No. 245 # 32C195

PIECE No.		QTÉ.
33A03	20 ECROUS DE BLOCAGE DE 1/4"	1
33A11	20 VIS À TOLE DE 1/4" x 2"	1
33A232	18 BOULON A OEILLET DE 5/16" x 3 1/2"	1
33A32	18 ECROUS HEXAGONAUX DE 5/16"	2
33A477	16 BOULONS H.H. DE 3/8" x 1"	1
33A4989	AGRAFE DE SURETÉ DE 5/16" No.3001	1
33A53	16 ÉCROUS DE BLOCAGE DE 3/8"	1
33A7881	901 CORDON EN FIL DE FER DE 197"	1
33A7883	901 CORDON EN FIL DE FER DE 117 1/4"	1
33A7898	401 CORDON EN FIL DE FER DE 86 1/4"	1
33B02	2001 ARTICLE No. 1250	1
33B63	RONDELLE SAE DE 3/8"	2
33B548	CHAINE À 5 MAILLES	1
41A882	2600 GUIDE EN PLASTIQUE	2

WARNINGS

PLEASE READ THIS SHEET CAREFULLY BEFORE STARTING TO USE THE ENCLOSED EXERCISE EQUIPMENT.

1. Always consult your doctor before undertaking any exercise program.
2. Ensure that all nuts and bolts are fully tight before using any exercise equipment.
3. Always wear suitable clothing and footwear e.g. tracksuit and training shoes.
4. Children should not be allowed on or around the machinery or equipment, even when not in use.
5. After eating allow 1 to 2 hours prior to exercising.
6. Always warm up well before exercising as this will prevent straining muscle.
7. Always read and follow the manufacturers assembly and user instructions.
8. Remove jewellery, rings, chains and pins before exercising.
9. Check for full engagement of locking pins.
10. Where applicable make sure weight retention collars are fully tightened.
11. Give special attention to the cables, pulleys and locking devices as they may wear.
12. Injuries to health may result from incorrect or excessive training.
13. Check that any of the adjustment devices are not projecting.
14. Always use your gym on a flat level surface.
15. Always use your gym in adequate space e.g. at least 2ft. (60cm) clearance on each side.
16. We recommend you never lift weights alone. There should always be someone available to assist you. Training with others can help motivate you.

N.B. this list should not be taken as exhaustive, there may well be other warnings needed on specialised equipment.

HOW TO LOCK YOUR GYM

IMPORTANT NOTICE

The U - Pin, Allen key and Collar have been supplied to enable you to lock your gym to prevent unauthorised use.

It is your responsibility to make sure your gym is not used without permission or supervision.

BAG 9436		32E72
Part No.	Description	Qty.
41D79	3mm Allen key	1
41D82	3/8" Steel Collar	1
41D81	U - Pin	1

Allen key (size 3mm)
If misplaced they can
be purchased from a
good hardware store.

(41D79)

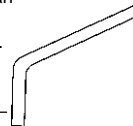

YORK BARBELL (U.K.) LTD.
CHURCHILL WAY, DAVENTRY,
NORTHANTS, NN11 4YB, ENGLAND
GENERAL ENQUIRIES
TEL: (01327) 701800
CUSTOMER SERVICE HELPLINE
TEL: (01327) 701824
FAX: (01327) 706704
E-MAIL: helpdesk@yorkfitness.co.uk

www.yorkfitnessworldwide.com

SHOULD YOU REQUIRE ASSISTANCE REGARDING WORN, MISSING OR DEFECTIVE PARTS PLEASE CONTACT OUR HELPLINE

WE WILL REQUIRE THE BATCH NUMBER (LOCATED ON A STICKER, ON THE BACK OF THE UPHOLSTERY).

IF PARTS ARE MISSING FROM THE BAG THEN WE WILL ALSO REQUIRE THE INFORMATION PRINTED ON THE BAG.

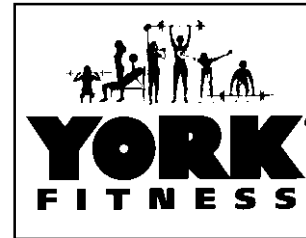

401 GYM

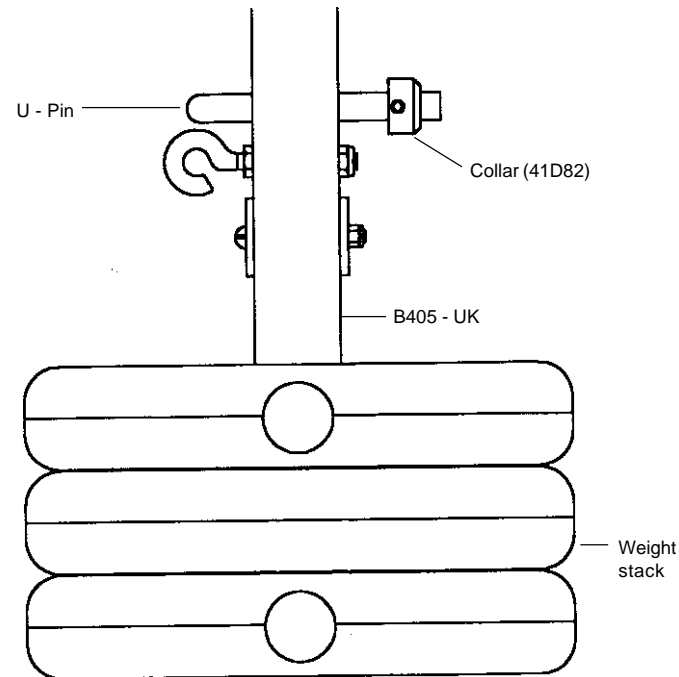

401 YORK Fitness

INFORMATION AND
LOCKING YOUR GYM