

HYPER-EXTENSION BENCH

CODE No.8117

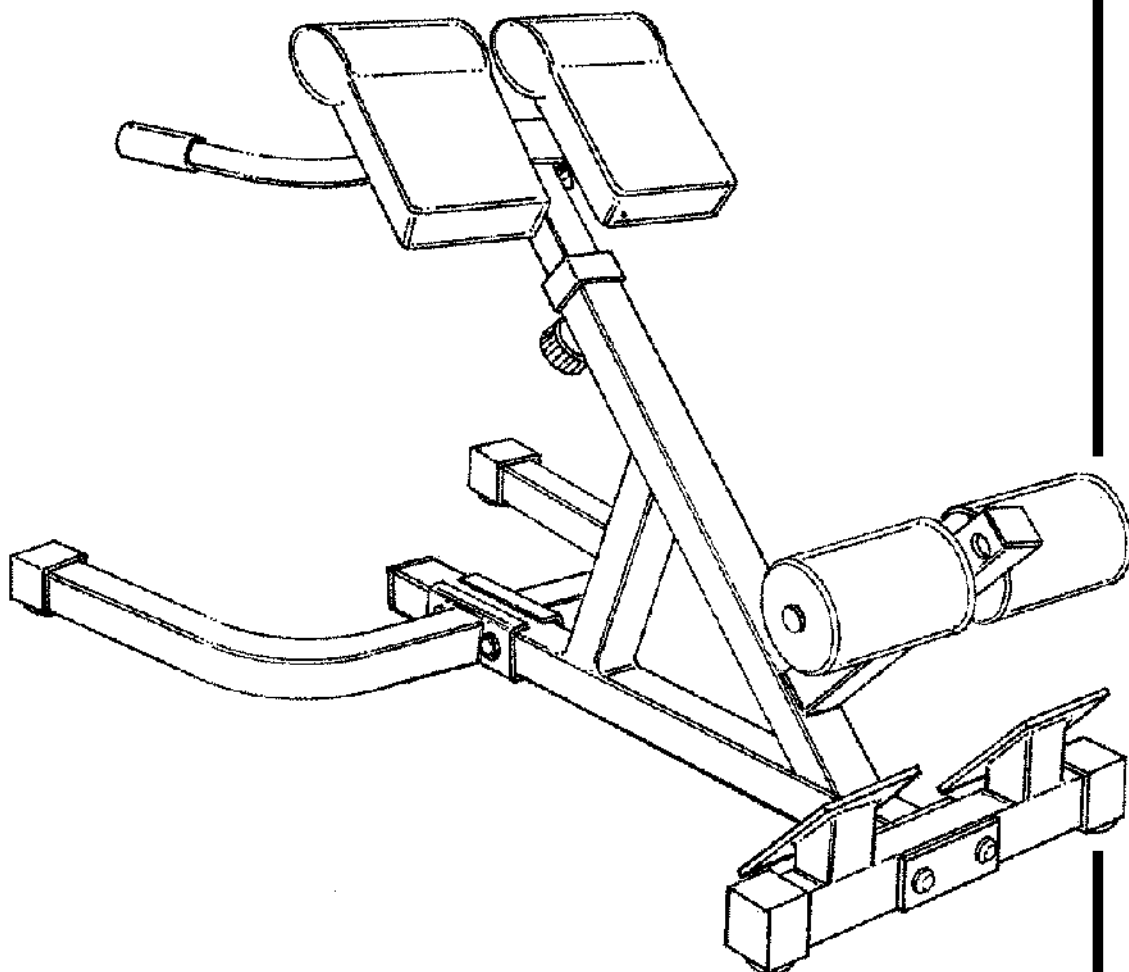

SPORTLINE
FITNESS

INSTRUCTION MANUAL

10 / 2002



YORK
FITNESS

SAFETY GUIDELINES:

BEFORE ASSEMBLY

- This must be read before you start assembling this unit.
- Great care has been taken in design and how to assemble this unit.
- All bags of nuts and bolts have been packed with ease of assembly in mind.
- You must follow the assembly instructions exactly as outlined.
- You will need at least one person to help you assemble this unit, two would be better.
- Assemble this unit starting at the beginning and work to the end.
- The assembly instructions are set out so that you are only doing one section at a time, therefore you will finish one section and move on to the next.
- If something is missing when assembling this unit, you must notify us of the part number of the exact nut, bolt of part that is missing.
- To help you assemble this unit we have used line drawings.
- Check the line drawings for the exact positioning of the parts.
- The unit will need to be checked at least once a week for nuts and bolts that can work loose, upholstered pieces working loose and wear on pivot assemblies.

WARNING: YOU ARE RESPONSIBLE FOR YOUR OWN SAFETY!!

WARNING

1. Always consult your doctor before undertaking any exercise program.
 2. Ensure that all nuts and bolts are fully tight before using any exercise equipment.
 3. Always wear suitable clothing and footwear e.g. tracksuit and training shoes.
 4. Children should not be allowed on or around the machinery or equipment, even when not in use.
 5. Do not eat large meals 2 to 3 hours before exercising.
 6. Always warm up well before exercising as this will prevent straining muscle.
 7. Always read and follow the manufacturers assembly and user instructions.
 8. Remove jewelry, rings, chains and pins before exercising.
 9. Check for full engagement of locking pins.
 10. Check that any of the adjustment devices are not projecting.
 11. Give special attention to the cables, pulleys and locking devices as they may wear.
 12. Inquiries to health may result from incorrect or excessive training.
 13. Always use your bench on a flat level surface.
 14. Always use your bench in adequate space e.g. at least 2ft. (60cm) clearance on each side and front (the rear can be close to a wall).
- N.B. this list should not be taken as exhaustive.

CARE AND MAINTENANCE

Use a warm, damp cloth with mild detergent to keep your bench clean.

TOOLS REQUIRED

The tool enclosed in the carton is one multi-purpose spanners.

SHOULD YOU REQUIRE ANY ASSISTANCE REGARDING THIS PRODUCT PLEASE CONTACT YORK DIRECTLY.

sportline
FITNESS

Distributed by:
YORK BARBELL (U.K.) LTD.
CHURCHILL WAY, DAVENTRY,
NORTHANTS, NN11 4YB, ENGLAND
GENERAL ENQUIRIES
TEL: (01327) 701800
CUSTOMER SERVICE HELPLINE
TEL: (01327) 701824
FAX: (01327) 706704
E-MAIL: helpdesk@yorkfitness.co.uk

www.yorkfitnessworldwide.com

sportline
FITNESS

Distributed by:
YORK FITNESS (TAIWAN) LTD.
4F-3. No.598. WEN SIN ROAD,
SEC 2, TAICHUNG,
TAIWAN, R.O.C
GENERAL ENQUIRIES
TEL: +886-4-2319-3448
FAX: +886-4-2319-3449
E-MAIL: yorktwn@ms25.hinet.net

www.yorkfitnessworldwide.com

sportline
FITNESS

Distributed by:
YORK BARBELL (AUST.) PTY. LTD.
UNIT 1, LOT 2, SWAFFHAM ROAD
MINTO, N.S.W. 2566
SYDNEY, AUSTRALIA
GENERAL ENQUIRIES
TEL: (02) 9603 8444
FAX: (02) 9603 8555
E-MAIL: paulyork@ozemail.com.au

www.yorkfitnessworldwide.com

ASSEMBLY INSTRUCTIONS

IMPORTANT -

This bench should be assembled finger tight in the beginning to allow for proper alignment.

- THIS BENCH IS FITTED WITH NYLOCK NUTS FOR SAFETY.
(THEY CAN ONLY BE TIGHTENED OR LOOSENED WITH TOOLS)
- FASTEN BENCH TOGETHER WITH THE BOLTS LOOSE.
FULLY TIGHTEN ALL BOLTS **AFTER** THE WHOLE BENCH HAS BEEN ASSEMBLED.

1

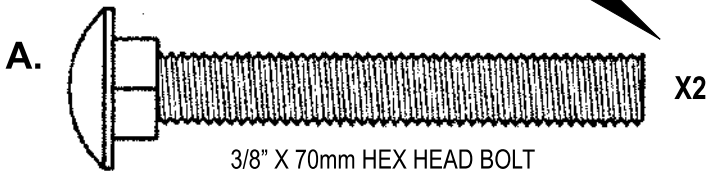
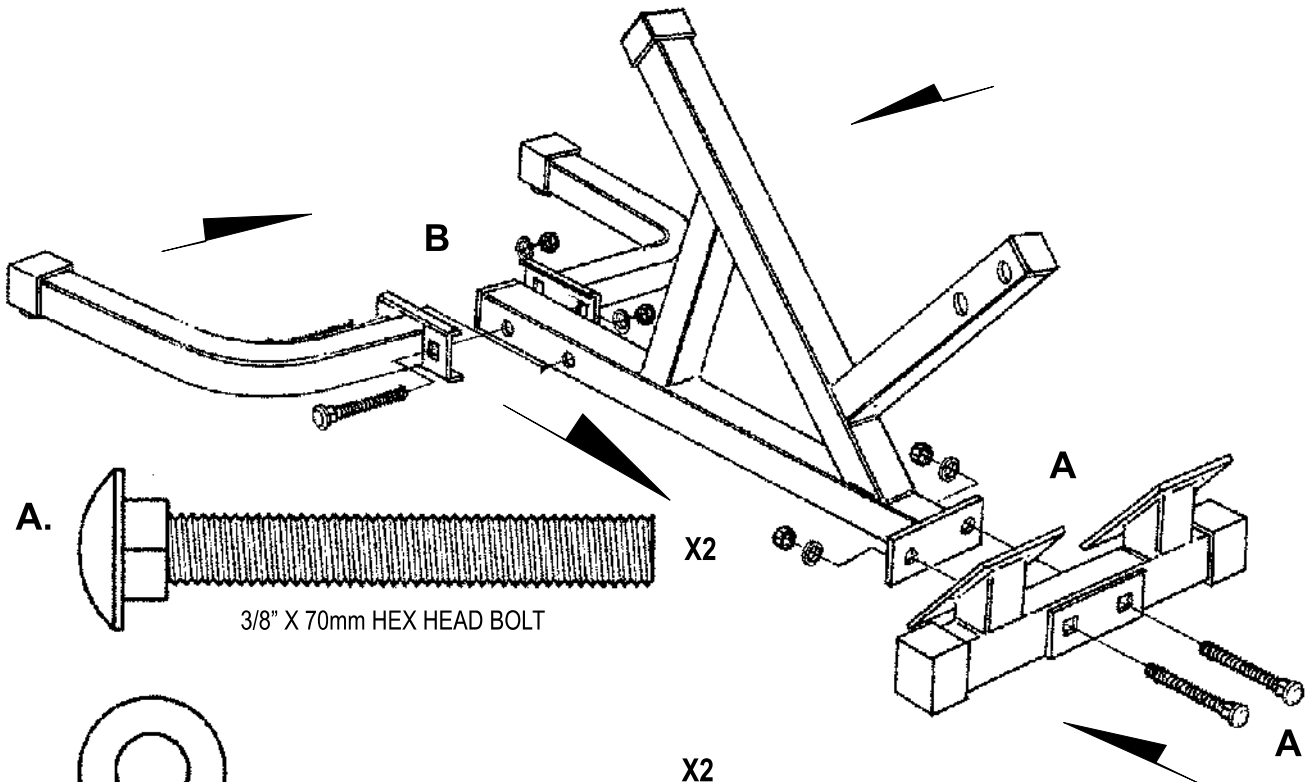
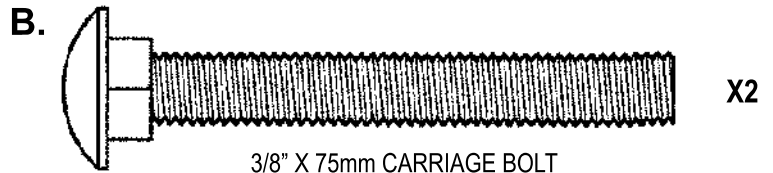

ASSEMBLY INSTRUCTIONS

IMPORTANT -

This bench should be assembled finger tight in the beginning to allow for proper alignment.

- THIS BENCH IS FITTED WITH NYLOCK NUTS FOR SAFETY.
(THEY CAN ONLY BE TIGHTENED OR LOOSENED WITH TOOLS)
- FASTEN BENCH TOGETHER WITH THE BOLTS LOOSE.
FULLY TIGHTEN ALL BOLTS **AFTER** THE WHOLE BENCH HAS BEEN ASSEMBLED.

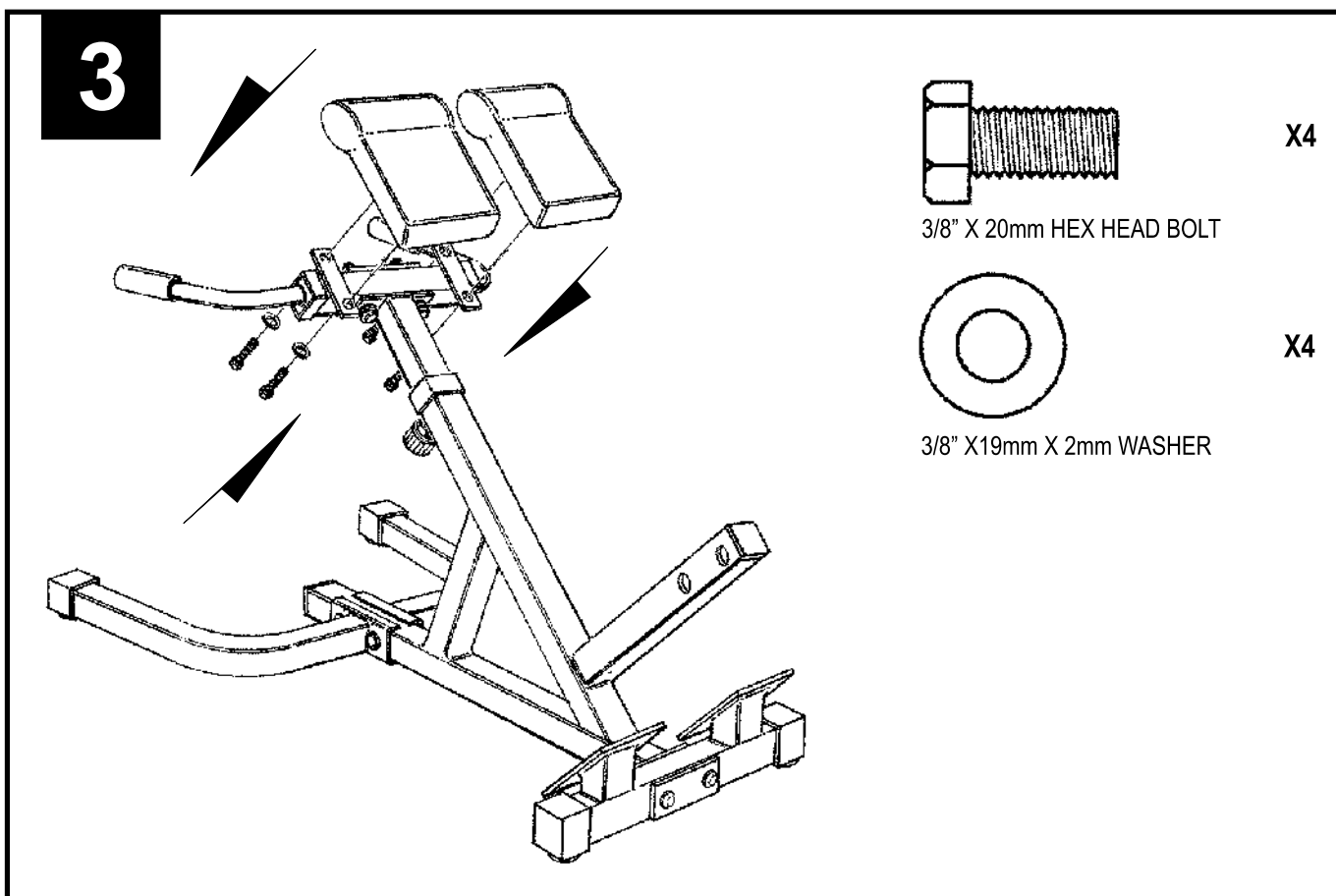
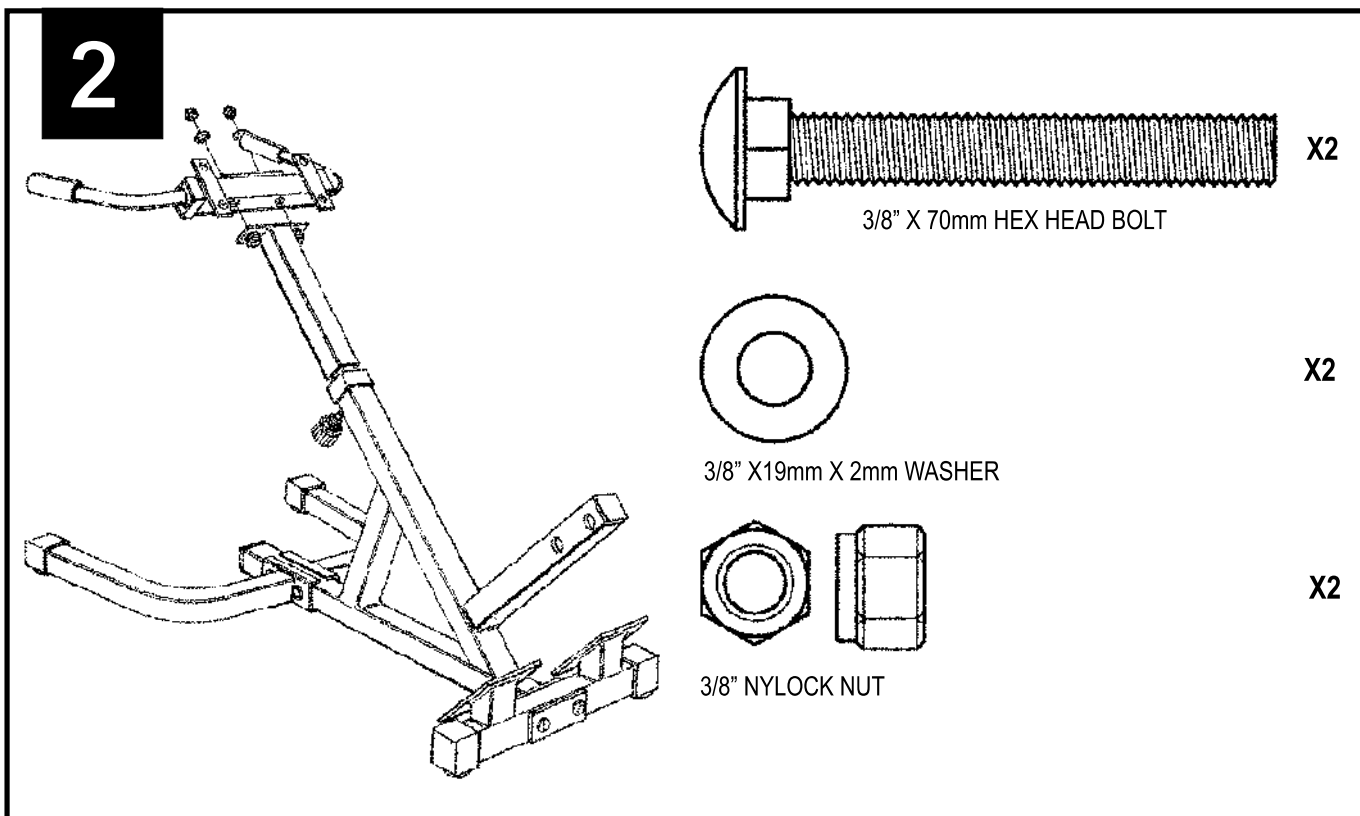

ASSEMBLY INSTRUCTIONS

IMPORTANT -

This bench should be assembled finger tight in the beginning to allow for proper alignment.

- THIS BENCH IS FITTED WITH NYLOCK NUTS FOR SAFETY.
(THEY CAN ONLY BE TIGHTENED OR LOOSENED WITH TOOLS)
- FASTEN BENCH TOGETHER WITH THE BOLTS LOOSE.
FULLY TIGHTEN ALL BOLTS **AFTER** THE WHOLE BENCH HAS BEEN ASSEMBLED.

4

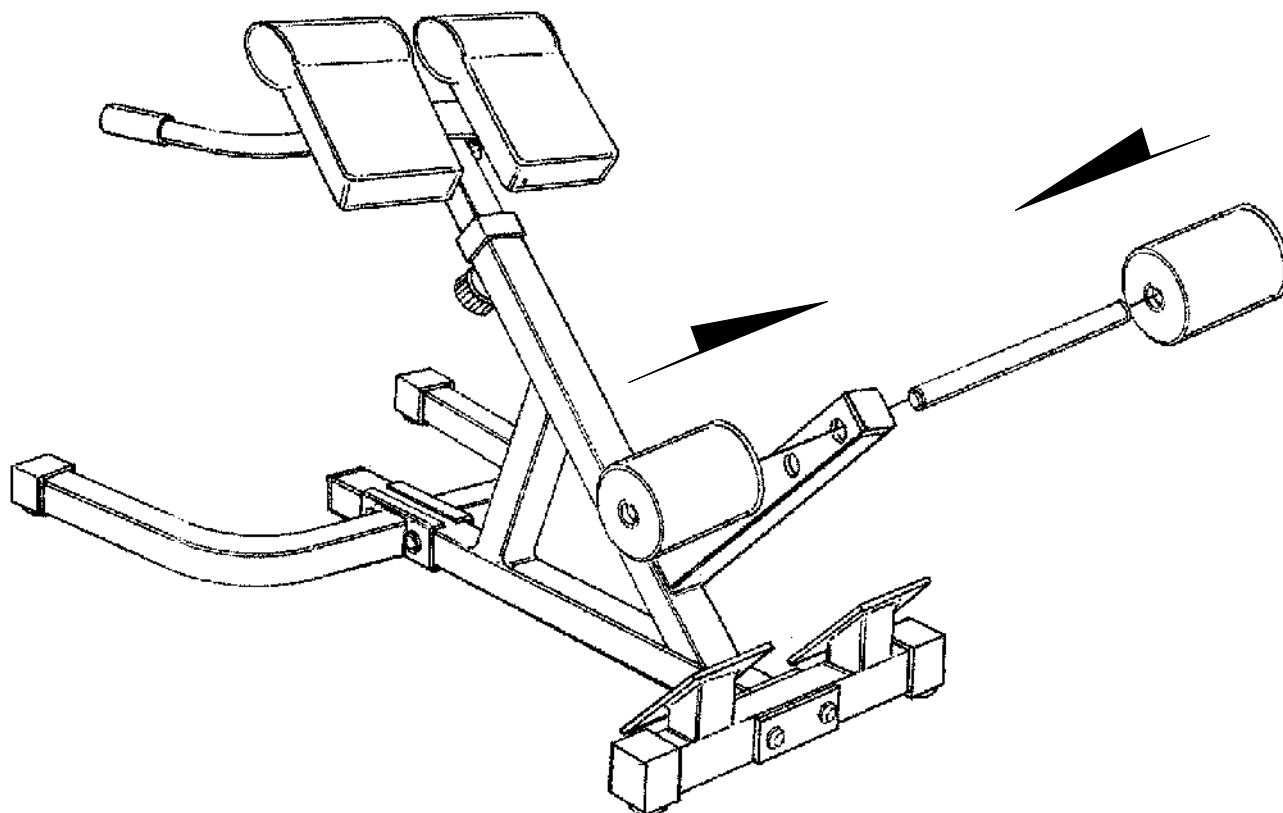

sportline - HYPER-EXTENSION BENCH

DESCRIPTION

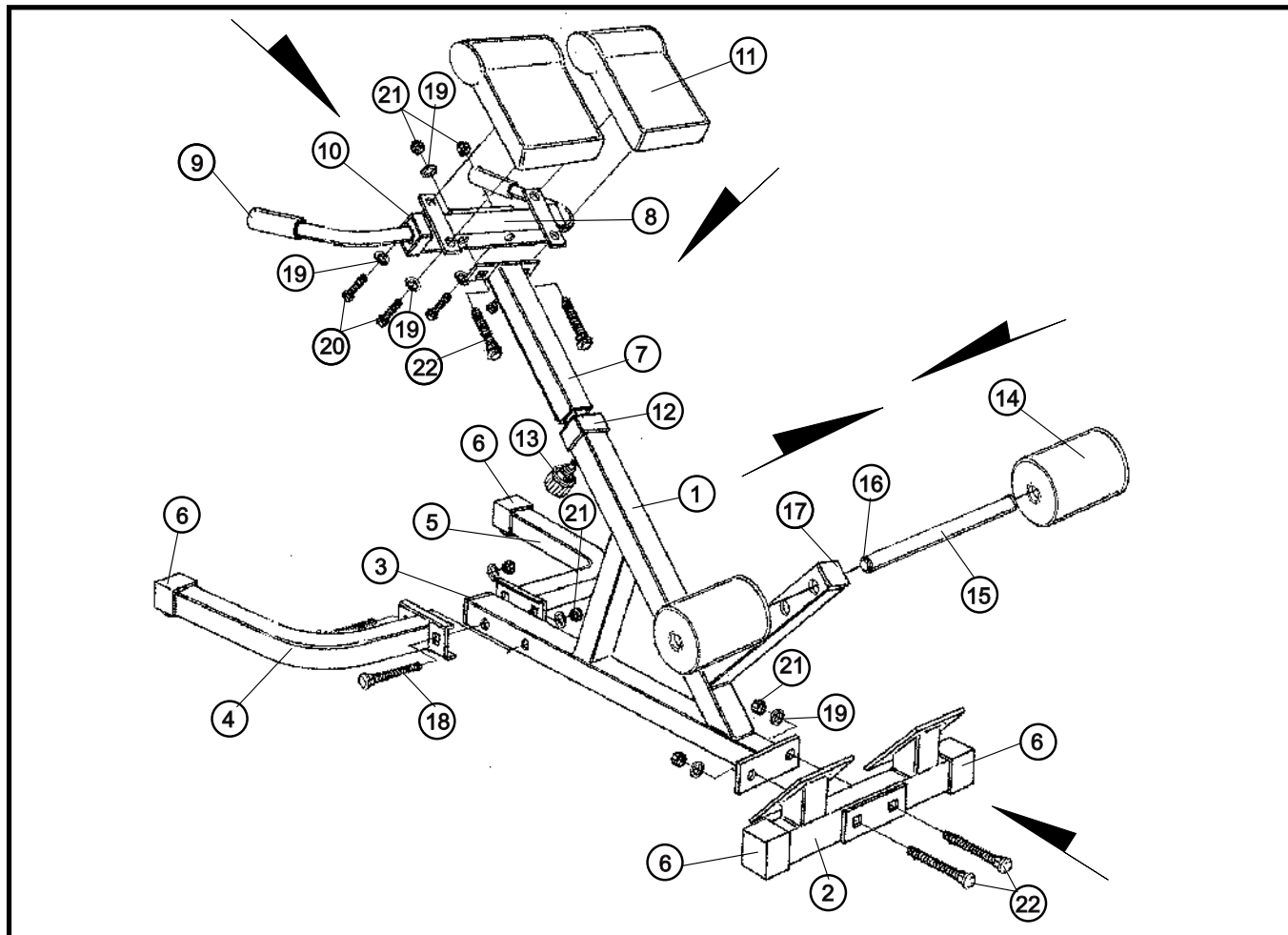

PARTS LIST

	PART NO.	Q'TY	DESCRIPTION
1	#8117-01	1	MAIN FRAME
2	#8117-02	1	FOOT REST
3	# 8117-03	1	2" SQUARE INT. END CAP
4	# 8117-04	1	LEFT FRONT STABILIZER
5	# 8117-05	1	RIGHT FRONT STABILIZER
6	# 8117-06	4	2" SQ. EXTERNAL CAP
7	# 8117-07	1	ADJUSTABLE HEIGHT POST
8	# 8117-08	1	FRONT HANDLE ASSEMBLY
9	# 8117-09	2	HAND GRIP
10	# 8117-10	2	SQ. REDUCER CAP W/ ROUND HOLE
11	# 8117-11	2	BENCH UPHOLSTERY
12	# 8117-12	1	SQUARE REDUCER CAP
13	#8117-13	1	QUICK RELEASED ADJ. KNOB
14	#8117-14	2	DIABLO NOMAPAD
15	#8117-15	1	LEG FOAM TUBE
16	#8117-16	2	1" END CAP
17	#8117-17	1	38mm SQ. INT. END CAP
18	#8117-18	2	3/8" X 75mm CARRIAGE BOLT
19	#8117-19	10	3/8" X 19mm X 2mm WASHER
20	#8117-20	4	3/8" X 1" HEX HEAD BOLT
21	#8117-21	6	3/8" NYLOCK NUT (THICK)
22	#8117-22	4	3/8" X 70mm CARRIAGE BOLT